

Hardware in the loop tests on eleven solar and heat pump heating systems

Robert Haberl, Michel Y. Haller and Elimar Frank

SPF Institut für Solartechnik, Hochschule für Technik HSR, CH-8640 Rapperswil, Switzerland

Abstract

Eleven heating systems that combine combistores with solar thermal collectors and heat pumps have been tested and evaluated as a whole by detailed measurements in a laboratory with the Concise Cycle Test (CCT). This hardware in the loop test utilizes the boundary conditions of climate and a typical load from a reference year in a representative 12-day test cycle. The complete systems were installed on a test rig that emulates a building and the tested systems acted autonomously to cover the heat demand for space heating and domestic hot water. The tests gave important insights into the behavior and the performance of these heating systems under transient operating conditions. One of the core findings is that the hydraulics and control strategy have a big influence on the temperature level of the heat pump condenser – and therefore also on the exergetic performance and the performance factor of the systems.

“*Keywords:* solar thermal; heat pump; combistore; whole system test; hardware in the loop”

1. Introduction

The efficiency of heating systems for domestic hot water (DHW) preparation and space heating is not only dependent on the efficiency of the single components, but also on their interaction. This is especially true for the combination of solar combistores with heat pumps (HP). The main reason for this is the strong dependency of the heat pumps’ coefficient of performance on the temperature difference between the source and the sink. The Concise Cycle Test (CCT) (Vogelsanger, 2003, Haller and Vogelsanger, 2005) is a method for complete heating systems under realistic conditions. It follows the “hardware in the loop” concept and was previously applied to systems that combine oil-, gas- and pellet boilers with solar thermal collectors (Haberl et al., 2009). Within the project Sol-HEAP, a contribution to the IEA SHC Task 44 / HPP Annex 38 (T44A38), the CCT method was extended to be able to test also systems with air source, ground source, and series connected solar and heat pump systems. One of the challenging aspects was to provide the heat source for the heat pump during a dynamic test and for dynamic climatic conditions in a realistic way. Finally, eleven system tests were carried out with systems from six different manufacturers that combine solar and heat pumps. This contribution gives an overview about the test method and the results of the tests.

Nomenclature

C	collector	Q	energy, kWh
CCT	concise cycle test	SPF	seasonal performance factor
COP	coefficient of performance	PF	performance factor
DHW	domestic hot water	T	Temperature, °C
Ext.	external	TES	thermal energy store
HP	heat pump	TiT	tank in tank
IHX	immersed heat exchanger	W	work, kWh

2. Methods

The Concise Cycle Test

The CCT utilizes the boundary conditions of climate and a typical load from a reference year in a 12-day test cycle. The complete system, including the HP, is installed on a test rig. The test rig emulates a building with its heat demand and heat sources, including the solar collectors and the heat source of the HP. The tested system has to act autonomously and deliver heat to the building to meet the comfort requirements for space heating and domestic hot water preparation. Different single family homes (SFH) with a heated living space of 140 m² in the climate of Zürich were used for the tests. The first tests were performed with a specific energy consumption of 100 kWh/(m²a) (SFH100). Further tests were carried out with a consumption of 60 kWh/(m²a) (SFH60) and 15 kWh/(m²a) (SFH15).

Emulation of the heat source for heat pumps

The aim of the test is to provide realistic and thus dynamic boundary conditions for the tested systems that include boundary conditions of the whole year. Hence it was necessary to implement also a realistic emulation of the heat source of the HP a: the ambient air, the ground, the solar thermal collectors, or a combination of multiple options.

Air source: A special designed climatic chamber is used to condition the ambient air temperature and humidity according to the climatic conditions that are also used for the simulation and emulation of the building and of the solar thermal collectors. The evaporator unit of air source heat pumps was placed in this climatic chamber. Thus, a realistic operation of the HP is ensured that contains, among other things, the defrosting of the evaporator.

Brine source: Brine source heat pumps were tested with either a borehole heat exchanger or solar heat from the collectors as a heat source. The so called EWS model of Wetter & Huber (2007) is used for an online simulation of the ground source with IEA SHC Task 44 / HPP Annex 38 parameters for the ground properties (Haller, 2013), and a borehole length of 2 x 115 m. During the 12-day test, the measured inlet temperature and mass flow is given to the simulation model and the return temperature from the simulation is then emulated by the test rig. Since the days of the test sequence represent a whole year within 12-days, a conditioning before and between the test days was necessary. For that purpose the simulation switched from the decelerated real-time synchronous simulation during a test day to the normal simulation speed for days of the meteorological year that are between the days that were selected for the test cycle. The load that is applied to the borehole during this period corresponds to a predefined load which is the same for all tested systems. For the use of solar thermal collectors as a source for heat pumps, both software and hardware for the emulation of the collector circuit were revised because the collectors may now be operated below the ambient temperature and also below the dew point temperature. Therefore the simulation model of the collectors was adapted and the ability of the test rig was upgraded for low temperatures.

Annual performance data

Subsequent to the physical system test the acquired data are suitable to generate a measurement-validated simulation model that can be further used to evaluate the system and to determine annual performance figures. This has been done for four of the tested systems.

3. Tested systems

All 11 tested systems (I to XI) have in common that they combine solar thermal collectors, a HP and a solar combistore into a single system. Apart from that the concepts differ significantly.

- **Heat sink of the solar collectors:** The collectors deliver heat to the combistore, the evaporator of the HP, a cold storage that is used as source of the evaporator of the HP, or a combination of multiple options.
- **Heat source of the heat pump:** The heat pumps absorb heat from the air, the ground, the collectors, or from a combination of multiple options.
- **Heat load of the building:** While some systems were designed and tested for extremely low energy buildings (passivehouse standard), others were designed for a higher heat demand.

Seven of the tested systems were using parallel system concepts, i.e. the solar collectors are only used to charge the combi-store. Five of them (I, VI, VII, VIII and IX) use a ground source HP. One of them has a condenser that is immersed into the combi-store as a distinct feature (IX) (compare Fig. 1 and Fig. 4). Two other parallel systems (II and V) use an air source HP (compare Fig. 2). The remaining four systems were parallel/serial systems where the solar thermal collectors provide heat either directly to the combi-store or as a source for the HP (III, IV, X and XI; compare Fig. 3 and Fig. 5). The special feature of the systems X and XI is the source of the HP which is provided by 30 m² façade-integrated solar collectors. These systems are intended only for passive houses with a correspondingly low space heating demand (SFH15).

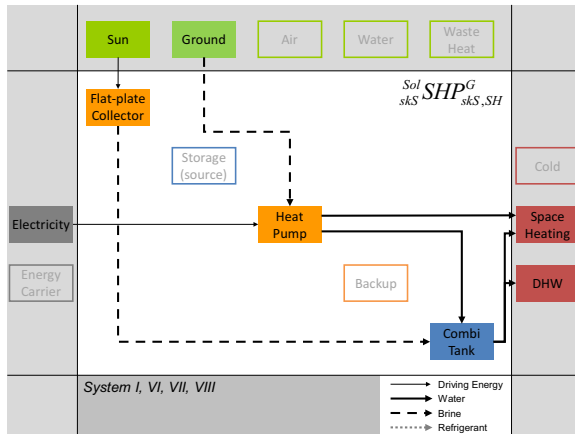

Fig. 1: Energy flow chart¹ of the systems I, VI, VII und VIII.

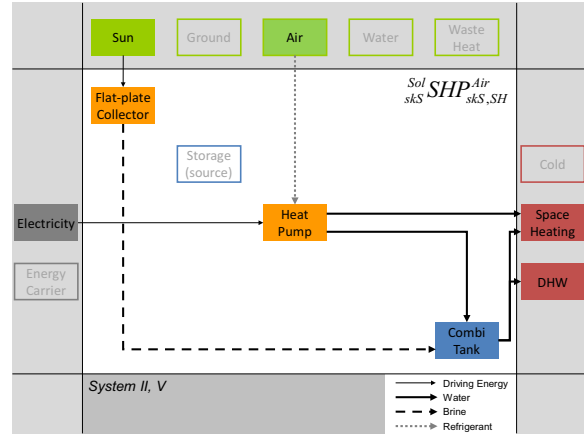

Fig. 2: Energy flow chart of the systems II and V.

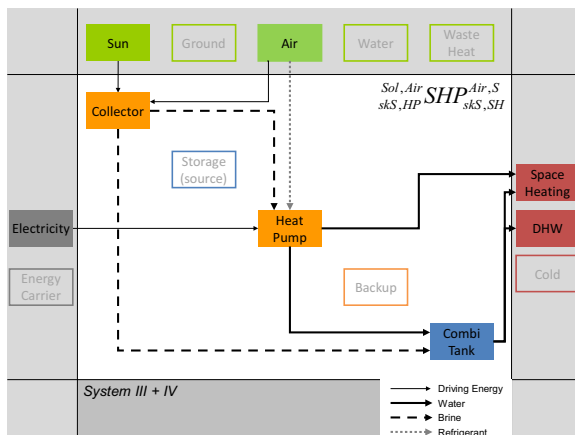

Fig. 3: Energy flow chart of the systems III and IV.

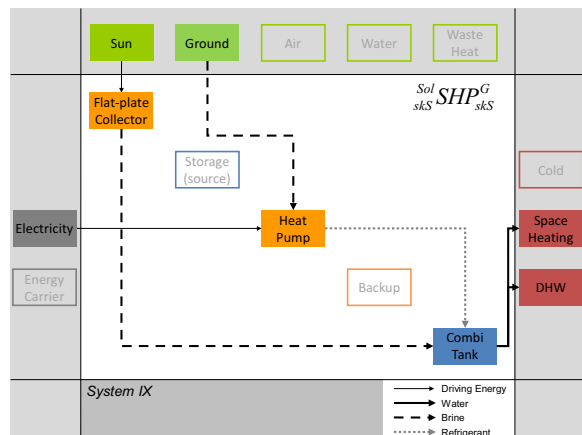

Fig. 4: Energy flow chart of systems IX.

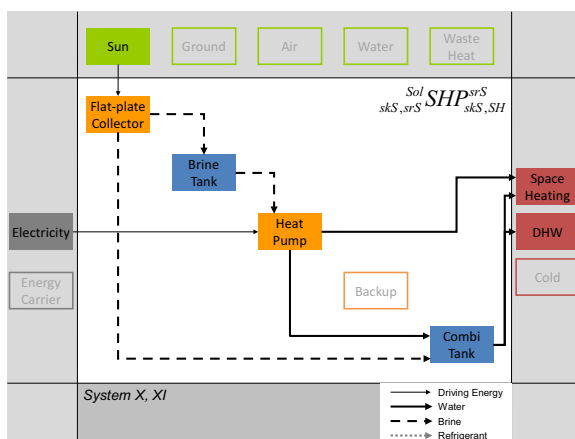

Fig. 5: Energy flow chart of the systems X and XI.

¹ A description of this way of representing energy flows for combined solar and heat pump systems can be found in Frank et al. (2010)

All of the tested systems were installed on the test rig by staff of the manufacturers. The test rig provides a technical room for this installation that is conditioned to 20 °C. Information about the components used in the different systems is given in Table 1. More details about hydraulic concepts and control strategies are not published by reason of the intellectual property rights and the anonymity of the manufacturers.

Tab. 1: Manufacturer's data about the heat pumps and storage tanks and information about the collector arrays that were emulated during the tests.

Heat pumps						
	min. / max. thermal output	max. electric power consumption			COP	
	[kW]	[kW]			[-]	
I	8.2 ^(a)	1.7			4.9 ^(a)	
II	3.1 / 8.3 ^(b)	2.4			3.7 ^(b)	
III + IV	n/a	n/a			n/a	
V	1.3 / 5.6 ^(b)	1.7			3.2 ^(b)	
VI - VIII	8.3 ^(a)	1.8			4.6 ^(a)	
IX	n/a	2.4			n/a	
X + XI	n/a	n/a			n/a	
TES						
	volume	diameter with insulation	Diameter without insulation	height	heat exchanger solar	DHW preparation
	[m ³]	[m]	[m]	[m]		
I + II	0.9	1.0	0.8	2.1	yes	TiT
III + IV	1.0	1.1	0.8	2.0	no	Ext.
V	1.0	1.0	0.8	2.2	yes	IHX
VI - VIII	0.9	1.0	0.8	2.1	no	Ext.
IX	0.8	0.9	0.8	2.0	yes	IHX
X + XI	1.0 ^(c)	1.0	0.8	2.2	yes	TiT
Solar thermal collectors						
	area of collector array ^(d)	η_0 ^(d)	a_1 ^(d)	a_2 ^(d)	type	tilt
	[m ²]	[-]	[W/(m ² K)]	[W/(m ² K ²)]		
I + II	12	0.73	3.5	0.01	flat plate	45°
III	15	0.75	3.4	0.01	flat plate	45°
IV	20	0.84	7.9	0.01	uncovered - selective	45°
V	10	0.73	3.7	0.01	flat plate	45°
VI - VIII	13	0.79	3.1	0.02	flat plate	45°
IX	10	0.72	3.3	0.02	flat plate	45°
X + XI	30	0.79	3.4	0.01	flat plate	90°

^(a) B0W35

^(b) A2W35

^(c) a second storage tank, filled with 0.08 m³ brine, was used on the source side of the heat pump.

^(d) based on the collector gross area

4. Results

Test sequence performance factors

Measurements were conducted at the interface between the test rig (that simulates and emulates the building, the domestic hot water draw profile, the collectors, and the source of the heat pumps) and the tested systems. The performance factors of the complete systems (PF_{SHP+}) were calculated according to Equation 1 that is in agreement with the definitions given in T44A38 (Malenkovic, 2012). It is calculated by the amount of heat that is delivered to space heating (Q_{SH}) and domestic hot water (Q_{DHW}), divided by the total amount of the electric energy consumption (W_{el}). That means that the system boundary for the energy balance includes all components that are installed in the technical room, including the TES and the heat distribution system (e.g. electricity consumption of the SH-pump). The achieved performance factors range from 2.7 to 4.8 during the 12-day system tests (compare Fig. 6).

$$PF_{SHP+} = \frac{Q_{SH} + Q_{DHW}}{W_{el}} \quad (\text{eq. 1})$$

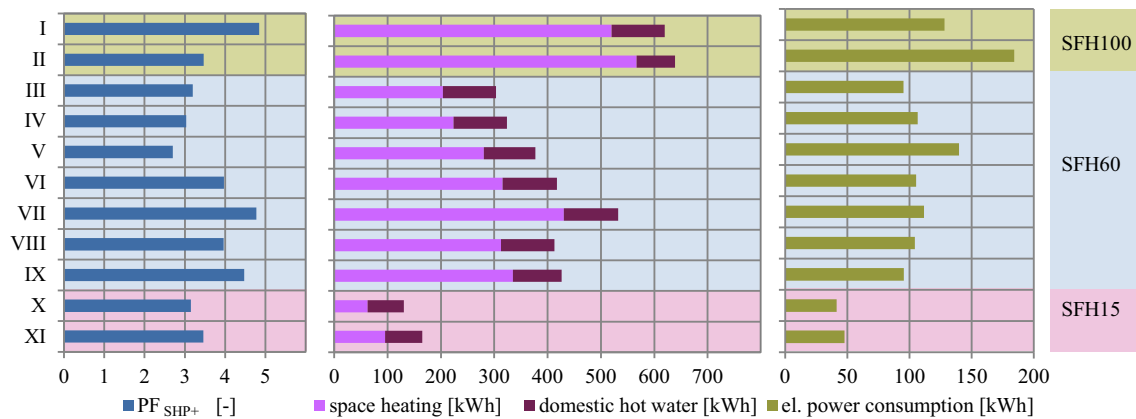

Fig. 6: Performance factors and energies of the tested systems determined with the CCT.

DHW-ratio

If possible, also temperatures and mass flows in the pipe connections between the HP and the combistore were measured. An interesting figure that can be calculated from such measurements is the ratio of the heat that was supplied by the HP in DHW-mode [kWh] divided by the heat drawn from the storage for DHW [kWh]. Taking into account the preheating of the cold water from the mains in the lower part of a combistore from 10 °C to approximately 30 °C (usual temperature in the middle of the TES), the HP only needs to heat from 30 °C to 45 °C in DHW mode. That means that the DHW-ratio should be lower than 100 %, and approaches zero with increasing solar fraction. Fig. 7 shows the DHW-ratio on a daily base during tests where this figure could be determined.

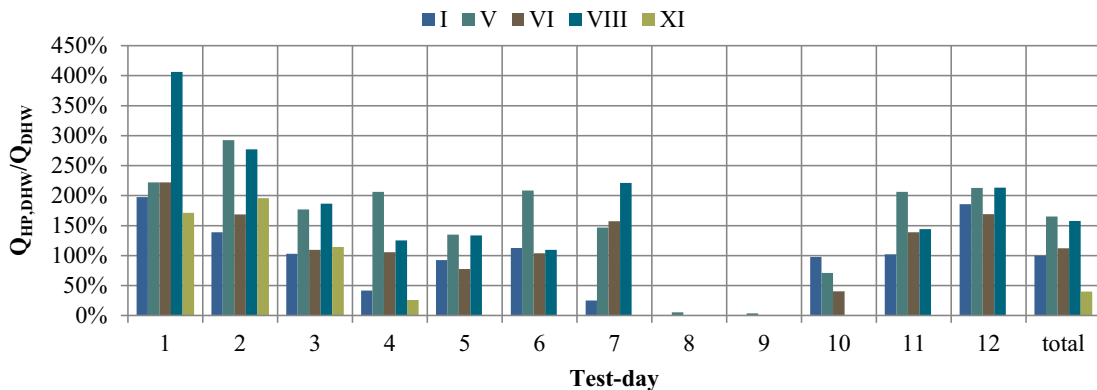

Fig. 7: Ratio of heat delivered by the heat pump in DHW-mode and heat consumed for DHW on the 12 days of the system tests.

Annual performance factors

Annual performance figures were only calculated for four systems: for the two systems that were tested with the SFH100 building and each one of the systems that were tested with the SFH60 and SFH15 building. The simulations were done with the respective annual load profiles and climatic data. For the SFH100 tests two additional simulations were performed using the SFH60 building. The results can be seen in Fig. 8.

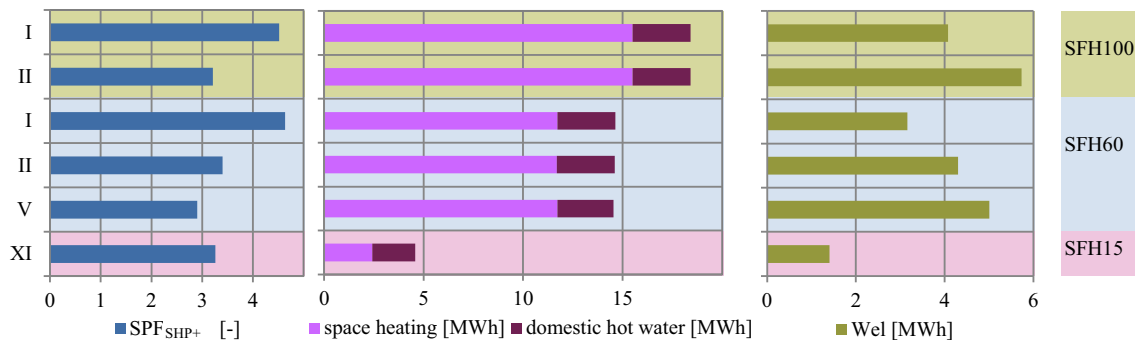

Fig. 8: Seasonal performance factors and energies of the tested systems on an annual base.

5. Discussion

Performance factors

The performance factors that were reached in the 12-day tests range from 2.7 to 4.8. But it is difficult to interpret or compare these numbers because the determining factors were not identical:

- The design space heat demand of the simulated building differed from 100 kWh/(m²a) for the first tests performed to 60 kWh/(m²a) for the new test standard applied, down to 15 kWh/(m²a) for the special case of a system that is only intended for the use in a passive house.
- The simulated space heat supplied deviates substantially from the design space heat demand, because the systems were let to deliver space heat according to their own control (thermostatic valves closing gradually when the simulated room temperature increased from 20 to 22 °C were simulated and the flow in the space heating loop reduced accordingly). As can be seen from the results, many systems delivered up to 50 % more space heat than needed for the most efficient space heat distribution control, and system VII with particularly unfavorable control settings delivered twice as much space heat as needed.
- Different collector areas were applied from 10 – 15 m² for the "normal" cases, with the exceptions of 20 m² for uncovered selective absorbers instead of flat plate collectors and 30 m² façade integrated flat plate collectors as the only source for the HP.
- Different heat sources for the heat pumps were used. Some heat pumps used ground source heat exchangers with a very constant source temperature whereas others had to deal with fluctuating temperatures of the ambient air and/or discontinuous solar irradiation.

Two of the ground source systems (I and VII) reached a performance factor of 4.8 during the 12-day test sequence. System I had to cover the SFH100 load, system VII the SFH60 load. The analysis of the results of system VII showed two problems: On the one hand the comfort requirements for DHW were not met and on the other hand the space heating load was much higher than necessary due to an erroneous parameter setting in the control of the system that lead to a continuous operation of the space heat distribution pump also in the summer period.

Electric energy consumption

The electric energy consumption during the 12-day tests can be seen in Fig. 6. Of particular interest are the electric energy consumption of the systems VI, VII and VIII, especially in combination with the space heating load and the performance factors. These three systems had identical components. They differ only in hydraulics and control. One can see that system VII shows the highest el. energy consumption of the systems and at the same time the highest performance factor. The reason for this was the already mentioned space heating

operation on summer days were operation with a high COP of the heat pump and a high solar fraction was possible – but not needed. In this case, the performance factor is not the appropriate value for system optimization.

Collector yield

The specific collector yield ranged from 7 to 16 kWh per m² gross area (cumulated during the 12-day test) . However, it must be noted that different types of collectors and different sizes of collector fields were used and that the integration of the collectors was implemented differently. Four of the tested systems were able to utilize the collector heat on the source side of the HP (in addition to direct charging of the combistore):

The systems III and IV utilized the collector heat in a parallel/serial system that had to cover the load of SFH60. The HP of both systems had the possibility to use the ambient air with a ventilated air heat exchanger as second heat source for evaporation. System III with flat plate collectors reached a specific collector yield of more than 15 kWh/m² in the 12 days while system IV with 20 m² of uncovered collectors reached only 12 kWh/m² (compare Fig. 9).

The systems X and XI also utilized the collector heat in a parallel/serial system, but without a second heat exchanger to utilize another heat source for the evaporator. Both used flat plate collectors in the southern façade of a building with a space heating demand of only 15 kWh/(m²a). These collectors were used to charge a cold store on the source side of the HP or to charge a combistore directly. The resulting specific collector yield is in both cases comparably low, but one has to keep in mind that the heat demand was also very low and that the collectors in this case have the additional benefit that cost and other inconveniences of an air or a ground heat source can be avoided.

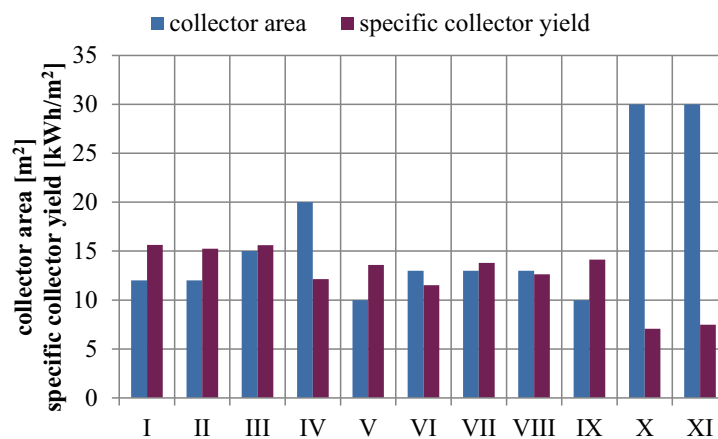

Fig. 9: Collector area and the specific collector yield of the 12-day tests.

Annual simulations

Subsequent to the 12-day test, the manufacturers had the choice to commission also annual simulations in order to obtain seasonal performance factors for comparable heat loads. This option was only chosen for a few of the tested systems.

DHW charging

Fig. 7 shown above shows the ratio of DHW heat delivered by the HP to heat supplied from the storage to the DHW distribution for six system tests where the corresponding energies have been measured. It can be seen clearly that the ratio is often close to or well above 100 % on the 12-day test sequence, and much higher than 100% in winter days. This is a strong indication that the DHW zone of the storage is disturbed by space heat operation, and the HP is charging the DHW zone more than necessary. A higher amount of heat delivered by the HP in DHW mode instead of the low temperature space heating mode reduces the seasonal performance factor of the HP significantly.

Exergetic analysis

Fig. 10 shows the accumulated energy (heat) that was measured during the 12-day tests below a certain supply temperature that is displayed on the x-axis for the systems I, V and XI.

In system I it can be seen that the (not inverter controlled) HP delivered its heat for SH at a temperature level between 32 °C and 40 °C whereas the consumption for SH (measured after the mixing valve) was at a temperature level between 23 °C and 33 °C. That means that the HP delivered its heat with a temperature that was around 8 K higher than the consumption (“A”). Assuming that the COP of the HP decreases by about 2 %/K, an increase in electric energy demand for the HP of approximately 16 % can be expected, corresponding to a reduction of more than 0.5 points of the performance factor. The share of heat that was supplied at over 40 °C roughly corresponds to the consumption of DHW (“B”).

In system V the difference between heat supply and demand in SH were merely 2 K. On the other hand, half of the heat that was delivered by the HP (about 160 kWh) at a temperature level above 45 °C (“C”) in DHW charging mode. This value is remarkably high, considered the fact that the consumption of DHW was below 100 kWh. Thus, some of the heat supplied at a high temperature level has been mixed down for SH at 25 °C and 30 °C.

The energy-temperature plot of system XI illustrates the functionality of the system that uses solar thermal collectors in parallel and also in series, as the only source for the HP. The solar collectors delivered heat to the source side of the HP (serial use) in a range of 0 – 50 °C, whereas the temperature where the collectors delivered heat directly to the combistore (parallel use) was always higher than 30 °C and mostly higher than 60 °C. The temperatures at which the heat pump produces heat in space heating mode correspond better to the SH flow temperature than in the other two systems.

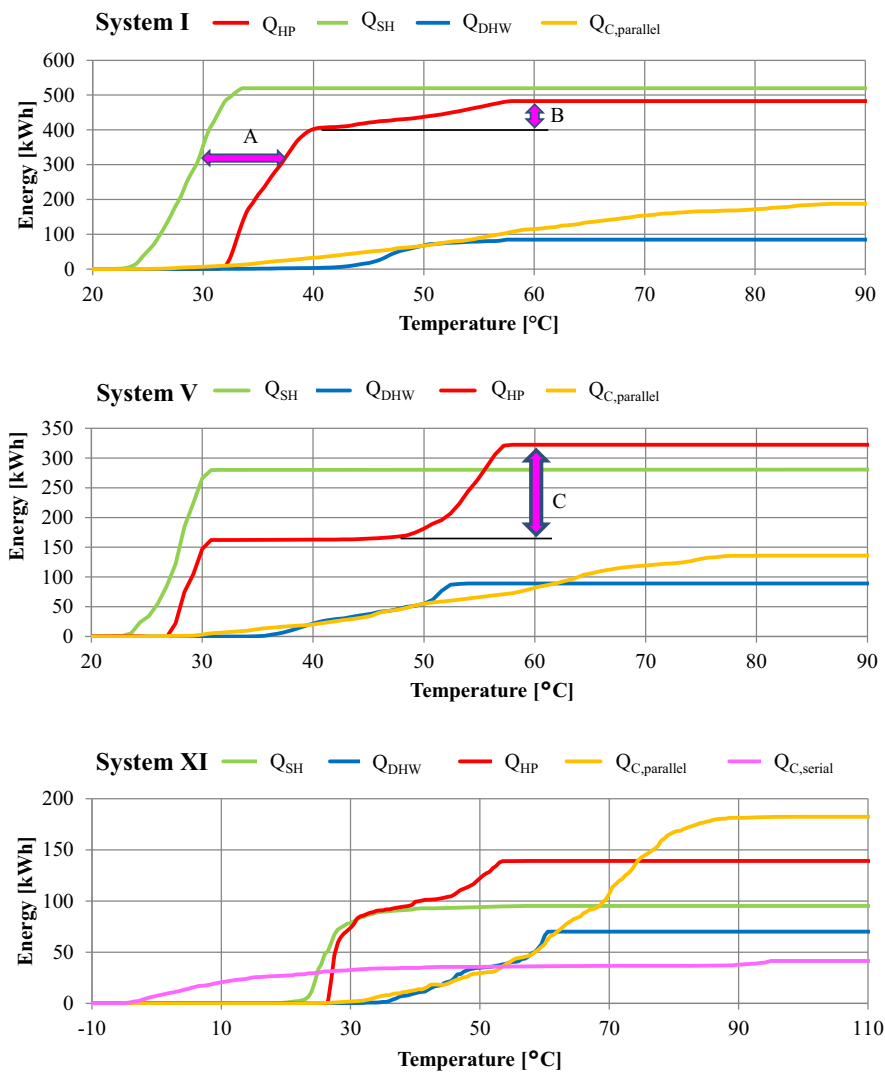

Fig. 10: Accumulated energy over the temperature where it was supplied (Q_{HP} , $Q_{C,parallel}$ and $Q_{C,serial}$) or consumed (Q_{DHW} and Q_{SH}). The decisive temperature is in each case the flow temperature.

6. Conclusion

Test method

The whole system test method CCT proved to be a valuable tool both for system development as well as for performance evaluation. The advantage of this kind of system test is that non-ideal component interactions and the influence of hydraulics and control under transient operating conditions can be detected and evaluated precisely. The test delivers within 12 days information about all operating conditions that may occur during a whole year and is thus much faster than field testing. Compared to field testing, the amount (number of sensors installed) and precision (high precision laboratory equipment used) of information that is obtained is much higher. Moreover, the results can be compared with tests of other systems that were performed under the same boundary conditions. Lack of repeatability is a major draw-back of field testing where the boundary conditions differ from case to case, which makes a direct comparison of the performance of solar and HP systems based on field testing extremely difficult or questionable.

A potential for improvement in the used test method lies in the fact that the space heat demand between the different tests was not identical. Instead, only the boundary for emulation of the space heat distribution and buildings were identical for QSH = 100, 60, and 15 respectively. As a consequence, the resulting electricity consumption and performance factors were highly influenced by the controller's settings for space heat distribution (i.e. settings for heating curve and heating season). Thus, a direct comparison of the system performance in terms of total electricity used and SPF can only be done with post processing of the data, i.e. simulations. This implies a large effort and highly skilled experts.

In the meantime a method was developed and successfully tested that guarantees an identical load for space heating while at the same time let the system act autonomously. This method is presented by Chèze et al. in the proceedings of this conference.

Data analysis

Two variants of data analysis proved to be helpful for the evaluation of the system performance:

- The ratio of heat delivered by the HP in DHW-mode and heat consumed for DHW.
- A visualization of the temperatures at which heat was supplied by the HP and the collector, compared to the temperatures at which heat was delivered for DHW and space heating.

Both are indicators for the exergetic efficiency of the storage system and the hydraulic solution, which is a decisive aspect for the efficiency of heat pumps in particular, and low exergy systems in general.

Test results

The test results show that only those systems achieved good results that prevented mixing processes and realized a good separation of temperature levels inside the combistore. In particular, the position of the DHW-sensor and the position of the outlets from the store to the HP turned out to be important. However, the measurements revealed optimization opportunities in the majority of the cases.

7. Acknowledgment

The authors acknowledge gratefully the financial support of the Swiss Federal Office of Energy (SFOE) within the project SOL-HEAP (project nr. SI/500494) as well as the European Union's Seventh Framework Program FP7/2007-2011 under grant agreement n° 282825 within the project MacSheep, as well as all companies that provided their systems for testing.

8. References

- Chèze, D., Papillon, P., Leconte, A., Persson, T., Bales, C., Haller, M.Y., Haberl, R., 2014. Towards an harmonized whole system test method for combined renewable heating systems for houses. Proceedings ISES EuroSun, Aix-les-Bains, France.
- Frank, E., Haller, M., Herkel, S., Ruschenburg, J., 2010. Systematic Classification of Combined Solar Thermal and Heat Pump Systems. Proceedings ISES EuroSun, Graz, Austria.
- Haberl, R., Frank, E., Vogelsanger, P., 2009. Holistic system testing - 10 years of concise cycle testing. roceedings ISES Solar World Congress, Johannesburg, South Africa.
- Haller, M., & Vogelsanger, P., 2005. Combisystem performance investigation. In J. C. Hadorn (Ed.), Thermal Energy Storage for solar and low energy buildings - State of the Art by the IEA Solar Heating and Cooling Task 32: IEA-SHC.
- Haller, M.Y., Dott, Ralf., Ruschenburg, J., Ochs, F., Bony, J., 2013. The Reference Framework for System Simulations of the IEA SHC Task 44 / HPP Annex 38 - Report C1 Part A: General Boundary Conditions - Final Revised, Rapperswil, Switzerland.
- Malenkovic, I., Eicher, S., & Bony, J., 2012. Definition of main system boundaries and performance figures for reporting on SHP systems. Technical Report IEA-SHC Task44 Subtask B, www.iea-shc.org/task44.
- Vogelsanger, P., 2003. The Concise Cycle Test Method - a 12 Day System Test. IEA-SHC Task 26 Solar Combisystems, Paris, France.