

BIPVT System Integrated with GSHP for Net Zero Energy Buildings

E. J. LEE^{1,2*}, E. C. KANG¹, K.S. LEE², M. Ghorab³, L. YANG³, E. ENTCHEV³

¹ Korea Institute of Energy Research, Deajeon, Republic of Korea

² University of Science and technology, Deajeon, Republic of Korea

³ Natural Resources Canada, CanmetENERGY, Ottawa, Canada

Abstract

One way to improve the efficiency of renewable energy system is by integrating two or more devices or so called the hybrid system. In this study, the change of the Ground Source Heat Pump (GSHP) seasonal performance factor will be observed when it is integrated with Photovoltaic-Thermal (PVT) to meet the multiple loads of house and office. Basically, the strategy to get this efficiency improvement is by combining the water outlet of GSHP which firstly heated by desuperheater and the output of PVT in one (preheat) tank. In the solar preheat tank, the heat from PVT will be added through heat exchanger as the supplementary to the hot water which is previously from city water passing desuperheater of GSHP. The final output of GSHP with the heat addition from PVT and the efficiency of stand-alone GSHP will be compared. GSHP-PVT hybrid system has the lowest energy consumption followed by GSHP stand-alone and reference case (simple sum of house and office) with 31.8kWh/m²-yr, 78.7kWh/m²-yr and 107

Keywords: *Ground Source Heat Pump (GSHP), Photovoltaic-Thermal (PVT), Multi-Load, Energy*

1. INTRODUCTION

The requirement for alternative low-cost and efficient energy sources has triggered people to the development of Ground Source Heat Pump (GSHP) system for residential and commercial heating and cooling applications. Earth temperature always sTab. throughout the year and this is also the reason why GSHP is very attractive. The heat pump on GSHP system operates using the same cycle as a vapor compression refrigeration cycle. Both systems absorb heat at a low temperature level and reject it to a higher temperature level. The difference between these two systems is that a refrigeration application is only concerned with the lower temperature effect produced at the evaporator, while a heat pump may be concerned with both cooling effect produced at the evaporator as well as the heating effect produced at the condenser in GSHP system. A reversing valve system is used to switch between heating and cooling modes by changing the refrigerant flow direction. GSHP system can be seen in Fig.1

A photovoltaic-thermal or PVT module is a combination of photovoltaic cells with a solar thermal collector, forming one device that converts solar radiation into electricity and heat simultaneously. The excess heat that is generated in the PV cells is removed and converted into useful thermal energy. The PVT system can produced efficiency up to 75% and as the efficiency of PVT increases, the cell temperature is decreased. PVT can be distinguished into two types based on the manufacturing process: PVT collectors and PVT panels. PVT collectors are very similar in appearance to a regular solar thermal collector, consisting of a PV-covered absorber in an insulated collector box with a glass cover. PVT panes on the other hands are similar in appearance to regular PV panels. Due to lack of extra insulation and a glass cover, PVT panes have a lower thermal efficiency but higher electrical yield. Fig.2 shows the PVT panels. In this study, two cases will be compared which are GSHP system and GSHP coupled by PVT system in order to perform the annual performance analysis.

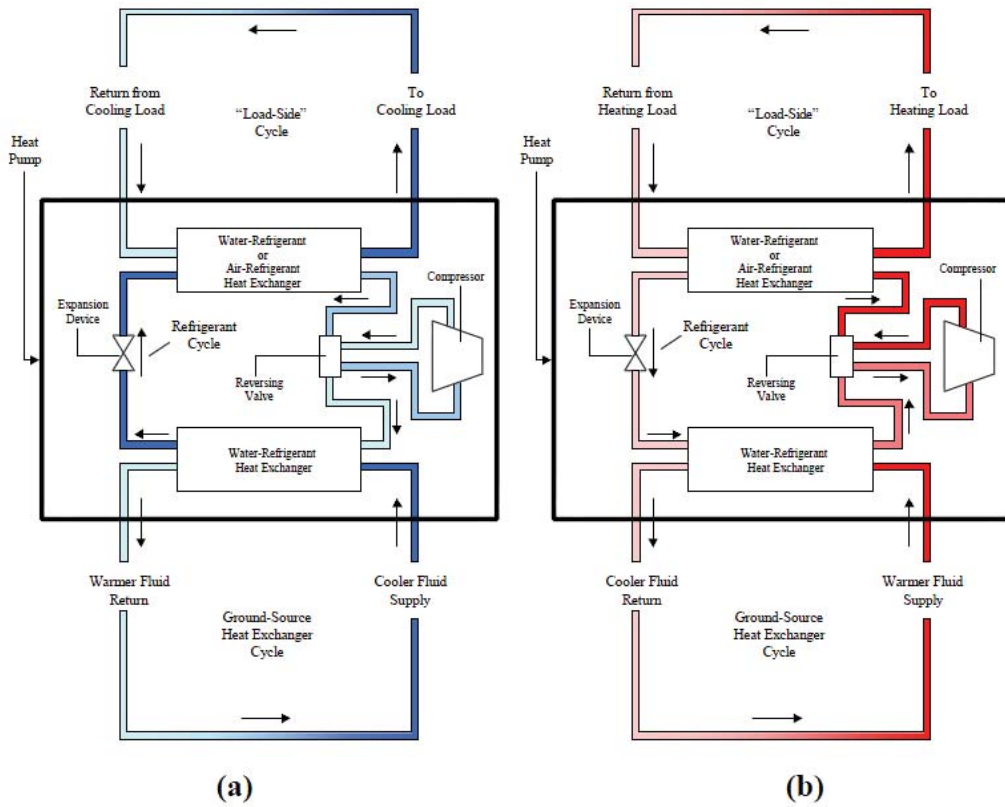

Fig.1. Ground Source Heat Pump (GSHP) Cycle in (a) Cooling mode and (b) Heating Mode



Fig.2. PVT Module

2. MICRO-GENERATION SYSTEM MODELING FOR EACH CASE STUDIES

In this study, three systems will be introduced for applications in residential and commercial buildings. Case one is simple sum of residential and commercial buildings (house and office) heating/cooling demand. Both thermal loads of residential and commercial buildings are provided by boiler and chiller system also fan coil unit as presented in Fig.3. The fan coil unit is located inside the building and a duct system is used to distribute the cooling/heating air inside the building. Domestic hot water (DHW) tank is installed inside the house and connected with the boiler via pipelines. This case will be the reference case for this simulation study.

Case two is a load sharing system with Ground Source Heat Pump (GSHP) to meet the combined load of houses and offices. Case two is load sharing hybrid system of GSHP integrated with PVT module. Load sharing in this case means houses and offices will use one system to provide heating and cooling demand instead of using separate system for each house and office. In case one, as presented in Fig.4, uses GSHP system to provide the heating/cooling demand instead of boiler/chiller system (conventional system). The desuperheater of GSHP is used to preheat the city water for DHW usage. A hot water storage tank is equipped to provide space heating and DHW heating. A gas burner is located at the bottom of the tank to provide supplementary heat in cases where GSHP alone cannot provide sufficient heat in very cold days or to heat the DHW water in summer. Water from the hot water tank is supplied to the two buildings through pipelines for DHW demand loads. In this case, the city water has enough pressure to flow the water in the system without using a pump. A cold water storage tank is used in the cooling season to provide chilled water for the cooling coils. Three way valves are used to switch between GSHP heating and cooling loops in winter and summer cooling seasons.

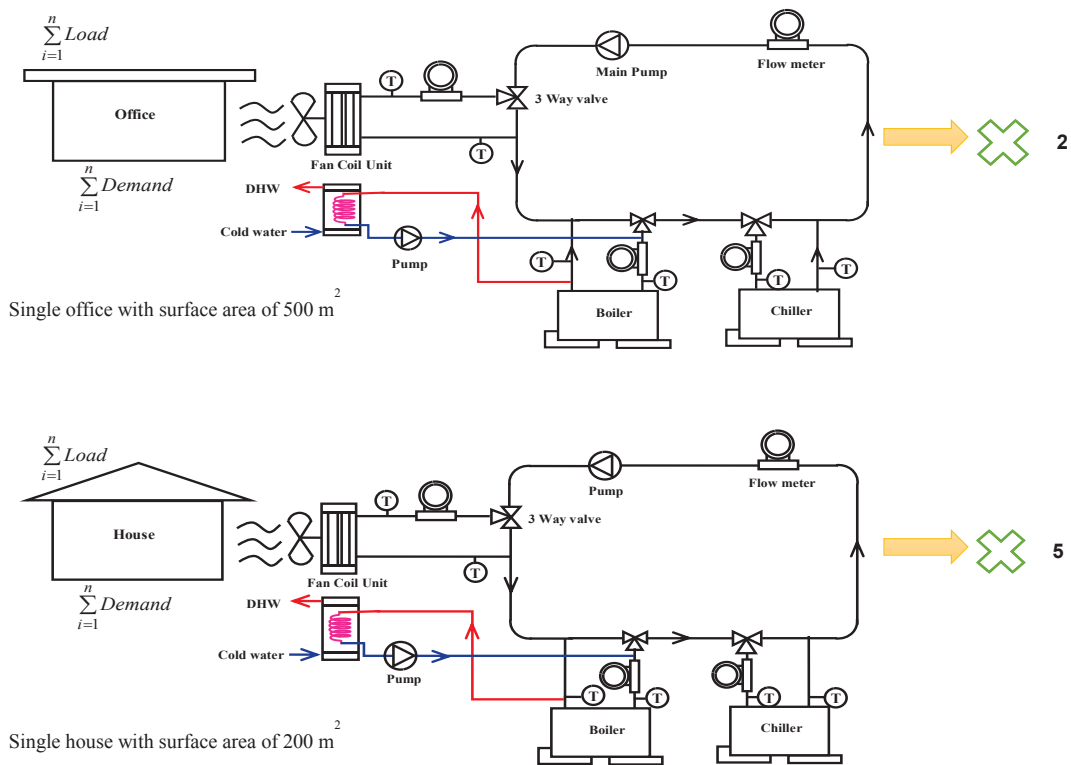

Fig.3. Simple Sum of Residential and Commercial Buildings System

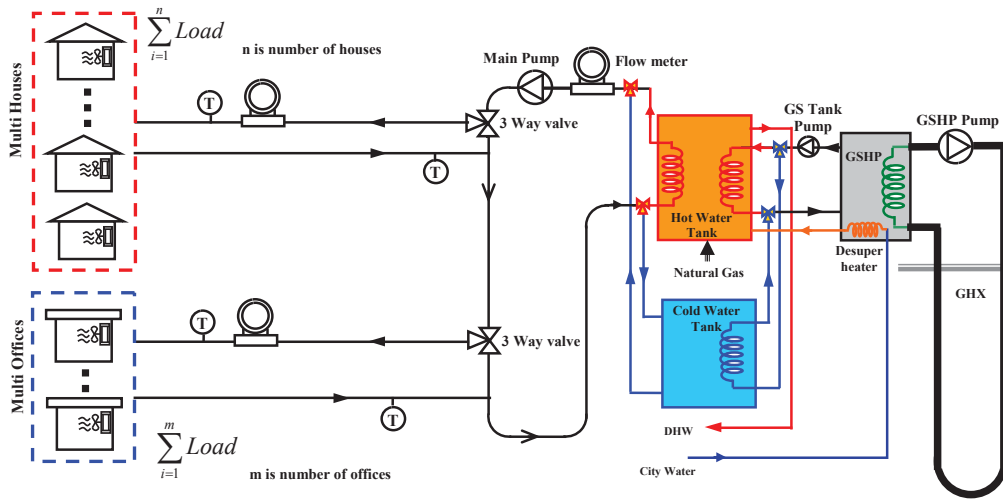

Fig.4. Load Sharing (Houses & Offices) Using GSHP System

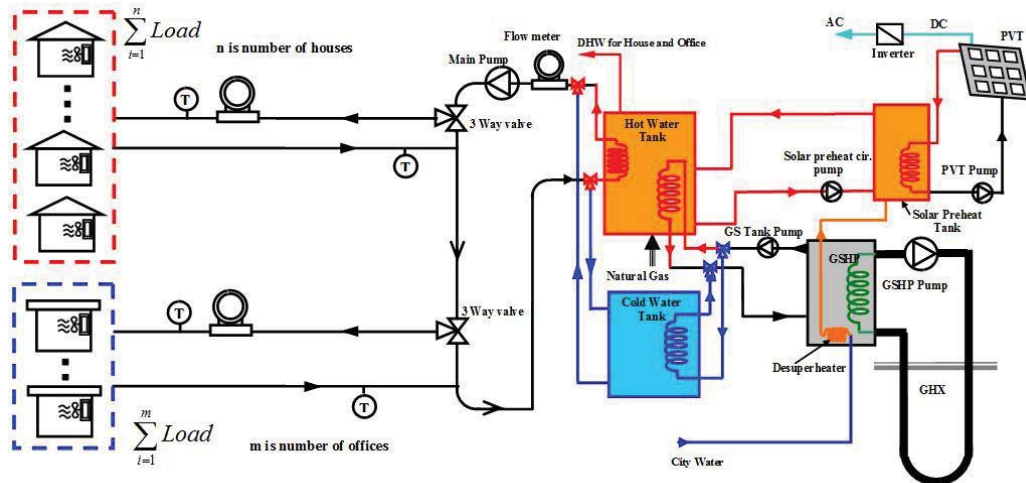

Fig.5. Load Sharing (Houses & Offices) Using Hybrid Micro-Generation System (GSHP-PV/T)

Tab. 1. Summary of Modelling Cases

| Cases | Heating/Cooling Systems | | | Remarks |
|--------|-------------------------|----------------------|---------------------------------|-----------------------------------|
| | Cooling | Heating | DHW | |
| Case 1 | Chiller + Fan-Coil | Boiler + Fan-Coil | Boiler + DHW Storage Tanks | Simple Sum Loads (House + Office) |
| Case 2 | GSHP - Fan-Coil | GSHP - Fan-Coil | GSHP (DSH) + Storage Tanks | Load Sharing |
| Case 3 | GSHP - Fan-Coil | PV/T- GSHP- Fan-Coil | PV/T-GSHP (DSH) + Storage Tanks | Load Sharing |

Case three is a hybrid micro-generation system integrating a photovoltaic thermal system to a GSHP system. PVT panels can generate both electric and thermal energy. The generated energy can be used to reduce the electrical power import from the grid to houses and offices and also used for space and water heating. There are many possible ways to integrate the PVT's thermal system to the GSHP system. In this study, system configuration with solar preheat-tank as shown in Fig.5 was chosen for the present study. The collected solar thermal energy is stored in a preheat-tank for two purposes: preheat the DHW and transfer the heat to the hot water storage tank in condition where the preheat-tank bottom temperature is few degree Celsius higher than the top of hot water storage tank. The remaining part of the system is same as that in case one.

Tab. 1 presents a summary of different modeling case studies and the corresponding technologies used for space heating, space cooling and DHW heating

3. SIMULATION AND ANALYSIS METHODOLOGIES

In the present study, all hybrid system models analysis from previous chapter are done by TRaNsient SYStems (TRNSYS-17) which a popular software platform for advanced dynamic building energy simulation. TRNSYS library includes a large database of component models related to buildings, thermal and electrical energy system, input and output data management and other dependent functions. All components models in this study were selected from TRNSYS libraries and enhanced with latest manufactures' system performance data. Additional models were developed for some components that are not present in the TRNSYS libraries such as PV module, GSHP desuperheater and etc.

Based on that approach, detailed simulation models were developed and applied for all three cases. In order to evaluate the load sharing system performance, multi-building block consists of five identical houses (with floor area 200m² each) and two identical houses (with floor area of 500m² each) were introduced. The building specifications meet the building envelope requirements for climate zone 4 recommended by ASHRAE Standard 90.1-2007.

For systems serving multiple buildings, it will typically have a lower thermal peak than the sum of thermal peaks of each homogeneous house and office. This is mainly due to the fact that individual buildings reach their respective thermal peaks at different times during the day. A load diversification factor is commonly used to take this phenomenon into consideration in load estimation and equipment sizing for systems that serve a number of mixed buildings. This factor is commonly in the range of 0.90 and tends to be lower when the central system serves a mix of office and residential buildings with peak demand occurring at different times.

The simulation models were run with Incheon, South Korea weather data over a year to simulate and analyze the energy systems' performance. The energy consumption results from the TRNSYS simulations were then used for energy and cost analyses to evaluate and compare the performance of various systems (cases)

4. ENERGY ANALYSIS RESULTS AND DISCUSSION

In this section, simulation results of the case one, case two and case three systems that serving multiple buildings (five houses and two offices) will be presented and discussed. While the houses are identical to the house studied in the previous section with a floor area of 200 m² per house, the office is enlarged and each has a floor area of 500m². The total combined floor area with five houses and two offices is 2000 m².

Both thermal and non-HVAC electric loads of the simulated houses and offices were analysed through appropriate time series methodology prior to the system simulation models development. The houses and offices were assumed to be separated from each other with no thermal interaction between them. Both type of buildings are square shaped and are assumed with a single interior zone in the simulations. The domestic

hot water volume assumption was according to ASHRAE-124 recommendations for residential and small office buildings. Non-HVAC electric loads were developed based on “average” consumption of a detached house and a small office in Canada which is 43.9 kWh/m²-yr. Those are presented in Tab. 2:

Tab. 2. Annual Thermal Load and Non-Electric Load Intensities

| Load Intensity (kWh/m ² -yr) | Building Blocks Five Houses + Two Offices (5x200 m ² + 2x500 m ² =2000 m ²) | |
|--|---|-------------|
| | Incheon | |
| | | |
| DHW | 8.6 | 6.6% |
| Space Heating | 47.2 | 36.1% |
| Space Cooling | 31.2 | 23.8% |
| Non-HVAC Electricity | 43.9 | 33.5% |
| <i>Total</i> | <i>130.9</i> | <i>100%</i> |

Initial simulation study found out that if a GSHP system integrates with PVT panels only, the PVTs thermal and electrical energy generations are restricted by the volume and temperature of the solar pre-heat tank directly and building thermal demand indirectly. Therefore, it may be more efficient to design a GSHP-PV/T system with combination of both PVT and PV panels rather than installing PVTs only. In this way, the electricity generation will not be restricted or reduced by the thermal demand compare to systems with all PVT panels. In addition, it is anticipated that the initial capital cost could be reduced as PV panels are usually cost less than PVTs. For this reason, 5 GSHP-PVT systems (Case 3) with various combinations of PVT and PV panels were simulated, as shown in Tab. 3:

Tab. 1. GSHP-PVT Systems for Simulation Study

| Number of PV Panels | Number of PVT panels | |
|---------------------|----------------------|------------------|
| | 0 | 60 |
| 0 | GSHP | GSHP-PVT60-PV0 |
| 120 | GSHP-PVT0-PV120 | GSHP-PVT60-PV120 |
| 240 | GSHP-PVT0-PV240 | GSHP-PVT60-PV240 |

Tab. 2. Energy Analysis of Multiple-Building for Each Case Study

| Incheon (Multiple Buildings) | | Five Houses + Two Offices (5x200 m ² + 2x500 m ² = 2000 m ²) | | | | | | |
|--|-------------|---|--------|--------------------|---------------------|--------------------------|---------------------|--------------------------|
| | | Case 1 | Case 2 | Case 3 | | | | |
| Energy Intensity (kWh/m ² -yr) | | SIMPLE SUM (REFEREN CE) | GSHP | PVT=6 0 PV=0 | PVT=0 PV=12 0 | PVT=6 0 PV=12 0 | PVT=0 PV=24 0 | PVT=6 0 PV=24 0 |
| Space + DHW Heating | N. Gas | 55.9 | 3.6 | 0.7 | 3.6 | 0.7 | 3.6 | 0.7 |
| | Electricity | - | 13.5 | 11.8 | 13.5 | 11.8 | 13.5 | 11.8 |
| Space cooling | Electricity | 16.2 | 8.6 | 7.9 | 8.6 | 7.9 | 8.6 | 7.9 |
| Fans | | 4.2 | 5.3 | 6.0 | 5.3 | 6.0 | 5.3 | 6.0 |
| Pumps | | 0.8 | 3.8 | 3.1 | 3.8 | 3.1 | 3.8 | 3.1 |
| Non HVAC (lighting, equip.) | | 43.9 | 43.9 | 43.9 | 43.9 | 43.9 | 43.9 | 43.9 |
| Electricity Production | | 0 | 0.0 | -3.8 | -19.0 | -22.8 | -38.0 | -41.8 |

| | | | | | | | |
|------------------------|-------|-------|-------|-------|-------|-------|-------|
| Total (Net) Energy Use | 107.6 | 78.7 | 69.8 | 59.7 | 50.8 | 40.7 | 31.8 |
| Energy Savings | - | 28.9 | 37.8 | 47.9 | 56.8 | 66.9 | 75.8 |
| Energy Savings (%) | - | 26.9% | 35.1% | 44.5% | 52.8% | 62.1% | 70.4% |

The result shows that the reference case (Case 1) has the highest total energy consumption at 107.6 kWh/m²-yr followed by GSHP system at 78.7 kWh/m²-yr and GSHP-PVT systems are showing better energy consumption compared to others ranged from 31.8 kWh/m²-yr until 69.8 kWh/m²-yr. The main reason why GSHP-PVT has better energy consumption is because this system only use small amount of natural gas for auxiliary burner inside the hot water burner and also GSHP-PVT system produced electricity so that reduced the net amount of energy consumption. Those results are shown in Tab. 4 and Fig. 6

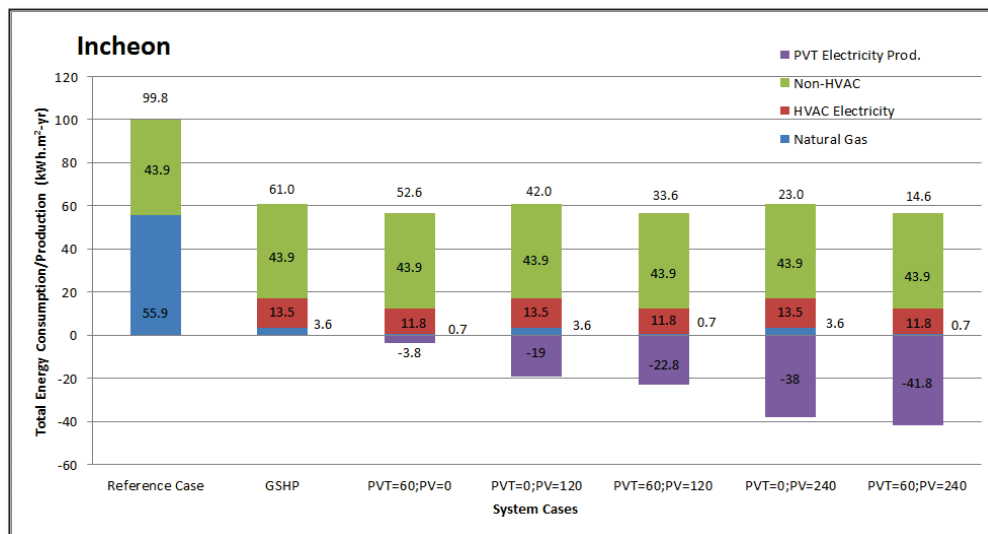

Fig. 6. Energy Analysis Results for Each Study Case

Based on those Tab. and graph, the system performance is evaluated and presented in COP values for the three studied cases. The COP is the ratio of the total energy delivered to the buildings (which includes space heating, space cooling, and DHW energy as well as electricity production if any) to the total consumed energy (natural gas and electricity) in the respective period as shown in Tab. 6

Tab. 3. System Performance (COP) For Multi-Building Cases In Incheon

| Incheon | COP | | |
|------------------|----------------|----------------|----------------|
| | Heating Period | Cooling Period | Overall/Annual |
| Reference System | 0.92 | 1.47 | 1.08 |
| GSHP | 2.87 | 2.09 | 2.50 |
| GSHP-PVT60-PV0 | 3.09 | 2.56 | 2.85 |
| GSHP-PVT0-PV120 | 3.42 | 2.64 | 3.05 |
| GSHP-PVT60-PV120 | 3.70 | 3.24 | 3.49 |
| GSHP-PVT0-PV240 | 3.97 | 3.19 | 3.59 |
| GSHP-PVT60-PV240 | 4.30 | 3.92 | 4.13 |

The result in Tab. 5 shows that Case 3 which is GSHP-PVT system has the highest COP ranged from 2.56 to 4.30 followed by GSHP system (Case 2) and simple sum of residential and commercial buildings (case 1).

This result indicates that hybrid system has a better performance compared to conventional system and GSHP-PVT is the best combination. One of the reasons is the additional contribution from solar energy to produce electricity so that electricity that consumed from the grid can be reduced as shown in Tab. 6

Tab. 4 Annual Electricity Generation and Supply of Various GSHP-PVT system

| Incheon | PV/T Electricity Generation | | System Electricity Supply | |
|------------------|-----------------------------|------------------|---------------------------|------------------|
| | Used by System | Exported to Grid | Supplied by PV/T | Supplied by Grid |
| Reference System | - | - | - | 100% |
| GSHP | - | - | - | 100% |
| GSHP-PVT60-PV0 | 100.0% | 0.0% | 5.2% | 94.8% |
| GSHP-PVT0-PV120 | 83.4% | 16.6% | 21.1% | 78.9% |
| GSHP-PVT60-PV120 | 80.5% | 19.5% | 25.2% | 74.8% |
| GSHP-PVT0-PV240 | 62.3% | 37.7% | 31.5% | 68.5% |
| GSHP-PVT60-PV240 | 60.0% | 40.0% | 34.4% | 65.6% |

The results in Tab. 6 indicate that the PV/T panels, depending on its capacity, meets 5.2% to 34.4% of the total electrical loads in Incheon. The remaining 65.6% to 94.8% required electricity is imported from the grid. Increase of the PV/T capacity certainly reduces the hybrid MG system's dependency on the electric grid, on the other hand this will result high initial capital costs

5. CONCLUSION AND FURTHER WORK

In this study, three different renewable and hybrid micro-generation cases were analyzed for application in combination of residential and commercial buildings. Five houses and Two Offices were selected in this study to perform the annual energy performance for each technology. Based on the result in previous chapter, we can conclude that:

- The total energy consumption of all the studied GSHP-PV/T systems (Case 3) is lower than that of the GSHP system (Case 2), and also the reference case (case 1) due to the use of geothermal and solar renewable energies. The overall system performance (COP) increases with the increase of the PV/T panels.
- The simulation results show that it is more efficient to design a GSHP-PVT system with combination of both PVT and PV panels. The PVT panels (operated with thermal-load control strategy) are primary used for covering part of the building heating loads and the PV panels (operated when there is solar radiation available) are mainly used for generating electricity for building usage. In this way, the electricity generation will not be restricted or reduced by the thermal demand compared to systems with all PVT panels. Any excessive electricity could be sold to the grid for additional income or stored in batteries for later use.
- Due to the PV/T electricity production is intermittent and not synchronized with the building demand, the GSHP-PV/T systems not only require electricity from the grid, but also have excessive electricity to be exported to the grid. The amount of electricity imported and exported to the grid is dependent on the number of the PV/T panels integrated to the systems.
- The GSHP-PV/T systems are able to meet 5.2%-34.4% of the building total electric load in Incheon. The remaining electric load is met by the grid. Increase the number of PV/T panels certainly reduces the system

dependency on the electric grid.

- For the simulated GSHP-PV/T systems, between 60% and 100% of the PV/T generated electricity is used by the buildings themselves and the remaining 0% to 40% excessive electricity is exported to the grid. The percentage of exported electricity increases with the increase of the PV/T panel numbers.

For Further work, an artificial intelligence (AI) control strategy to be embedded in a gateway wireless platform for optimal control of the hybrid system will be developed. The strategy will be simulated and investigated for variety of system sizes and applications. The hybrid systems will be optimized and the optimal component and system configurations will be simulated and assessed for maximum utilization. Variety of simulations will be conducted using system integration optimization technique to approach real life situations where a group of multi-type buildings will be served by the hybrid energy system in load sharing applications. Further, and more in depth, economic analyses will be performed to investigate the viability of the hybrid energy systems in selected scenarios and their impact on the overall installation and operation costs.

6. ACKNOWLEDGEMENT

This research was supported by a grant(code# 16CTAP-C096424-02) from Technology Advancement Research Program (TARP) funded by Ministry of Land, Infrastructure and Transport of Korean government

7. REFERENCES

- E. Saloux, A. Teysseidou, M. Sorin 2013. "Analysis of photovoltaic (PV) and photovoltaic/thermal (PV/T) systems using the exergy method" Energy and Buildings Journal, Vol.67, pp.276
- Entchev, E. Yang, L. Ghorab, M. 2013. "Photovoltaic Thermal-Ground Source Heat Pump Simulation Study, Second year report". CanmetENERGY-Ottawa, Natural Resources Canada.
- Lee, E.J. Kang, E.C. Cho, S.Y. Entchev, E. Yang, L. Ghorab, M. Performance Assessment and Integral Effect Test of Fuel Cell – Ground Source Heat Pump and Photovoltaic Thermal – Ground Source Heat Pump. Annex54-KIER- subtask B report. Available from: <http://www.annex-54.sharepoint-live.de>
- Lee, E.J. Kang, E.C. Cho, S.Y. Entchev, E. Yang, L. Ghorab, M. Performance Assessment and Integral Effect Test of Fuel Cell – Ground Source Heat Pump and Photovoltaic Thermal – Ground Source Heat Pump. Annex54-KIER- subtask C report. Available from: <http://www.annex-54.sharepoint-live.de>
- Dott, R., M. Haller, H, J. Ruschenburg, F. Ochs and J. Bony, 2012, IEA-SHC Task 44 Subtask C technical report: The Reference Framework for System Simulation of IEA SHC task 44 / HPP Annex 38: Part B: Buildings and Space Heat Load, IEA-SHC, Paris, www.iea.org/task44
- Stegman M., Bertram E., Rockendorf G. & Janben S., 2011. Model of an Unglazed photovoltaic thermal collector – based on standard test procedures. Proc. Of ISES Solar World Congress 2011, Solar Heating and Cooling, International Solar Energy Society (ISES), p.252-260, Kassel, Germany
- Clean Energy Project Analysis: RETScreen Engineering & Cases Textbook Ground-Source Heat Pump Project Analysis Chapter, Minister of Natural Resources Canada