

## Efficiency Analysis of Solar Assisted Heat Supply Systems in Multi-Family Houses

Oliver Arnold<sup>1</sup>, Oliver Mercker<sup>1</sup>, Jan Steinweg<sup>1</sup> and Gunter Rockendorf<sup>1</sup>

<sup>1</sup> Institut für Solarenergieforschung Hameln (ISFH), Am Ohrberg 1, 31860 Emmerthal (Germany)

### Abstract

There are two major approaches to mitigate energy-related emissions of dwellings: Insulating the building's envelope on the one hand and modernizing its heat supply system on the other hand. Often the insulation of dwellings leads to lower energy savings than expected (Greller et al., 2010), which is assumed to be related to the heat losses of the heat distribution system itself. So attention needs to be drawn to the modernization of the heat supply system, which can lead to a significant reduction of the building's final energy demand (Jahnke et al., 2015). This paper is following this approach and focuses on the heat supply and distribution system of multi-family houses (MFH), representing a significant share of Germany's residential market. The present work compares different systems for multi-family houses by means of its primary energy demand, energy efficiency and economic aspects. Heat distribution losses are analyzed and their relevance for efficient systems is discussed. Based on this analysis, the work highlights effective integration routes of solar thermal supply systems which may lead to increased efficiency of the overall heat supply system.

Keywords: *Multi-family houses, heat supply, heat distribution, heat distribution losses, energy efficiency*

---

### 1. Introduction

Measured energy demands of insulated dwellings are often higher than theoretically expected, as shown by Majcen et al. (2013). One reason for this are so called 'rebound effects' caused by the dwelling's inhabitants, such as higher room temperatures or higher air exchange rates, which are difficult to model. Another, technical reason for the observed model/measurement divergences are commonly related to heat losses of the heat distribution system. A part of the distribution losses replaces normal operation of the room heating elements and thus may be credited to the energy demand. However, if there is no heat demand at a certain time and in an individual room, occurring distribution losses lead to overheating and as a result to increased transmission and ventilation losses of the building. In this case, the usability of the heat losses is very low. This effect is pronounced in well insulated buildings. In the present paper, this situation is analyzed by means of simulation studies.

A detailed model of a multi-family house has been established, using the TRNSYS software as appropriate modelling environment. The underlying building model refers to typical construction types and equipment which is representative for multi-family houses in Germany. The model allows the dynamic investigation of temperatures, mass flow rates and energy balances as well as the impact of heat distribution losses of individual rooms as well as the entire building. This allows a detailed investigation of the heat losses and their potential contribution to the space heating demand. As a matter of fact, such analysis must be based on simulations, because reproducible and highly analyzable field data are impossible to determine because of the enormous number of parameters, the inhabitant's behavior, the building and weather dynamics and distributed energy flows.

The modelling of the building's heat demand is based on an investigation of different systems that will be compared and rated in this paper. This investigation is initiated concerning the most common heating system in Germany. Based on this, different approaches are rationalized to reduce respective heat distribution losses, in order to improve their usability and – thereby – to decrease the system's energy demand.

Eventually, a solar thermal system is suggested as effective approach to increase the energy efficiency of the building. The appropriate design of such solar thermal system is explained related to the analysis of building and energy system and economical aspects are reflected.

## 2. Simulation environment, building and meteorological model

The simulations are carried out employing the TRNSYS 17 modelling suite, a dynamic system simulation program. The temporal resolution is adjusted by a simulation time-step of one minute and the timescale of a typical simulation spans a one-year period. The building's heat distribution system is modelled quite detailed to correctly simulate the dynamic behavior of the heat distribution and especially the heat losses. It regards over 100 duct sections (using Type 604) for proper spatial resolution of the heat distribution system in the building, which are capable of dynamically calculating heat losses under local thermal and flux conditions.

The model of the considered multi-family house (MFH) was built employing the module TRNBUILD. The model is based on statistical data of MFH designs in Germany. The model comprises four floors, unheated basement and staircases and eight identical flats. Each flat contains five rooms and a corridor. The model assumes an occupation by two dwellers per flat. Every room of the building represents an individual thermal zone which is thermally interacting with adjacent rooms (zones) through walls, floors/ceilings and pipe ducts. In total, the model building consists of 52 thermal zones. The outer shell of the building is assumed to be insulated according to the corresponding German regulation EnEV (2014), always using the minimum values defined by here. For the internal room temperatures a set point of 20 °C is used. The climate model is based on Meteornorm data for the city of Zurich (Swiss), which is proven to be appropriate for central-European moderate climate situations, see Streicher et al. (2003). The resulting specific overall space heating demand of the model building is 35 kWh/(m<sup>2</sup> a) and a total heat demand is 56 kWh/(m<sup>2</sup> a). This includes load profiles for domestic hot water as described in Mercker et al. (2016a).

## 3. Investigated Systems

### Four-line pipe network (4L)

A four-line heat distribution network with central heat generation, as shown in Figure 1, is a very common heat supply system for MFH in Germany, see Wolff et al. (2012). Heat for space heating (SH) and domestic hot water (DHW) is distributed via two separate pairs of pipes. The DHW is stored in a central storage at a minimal temperature of 60 °C for hygienic reasons. The heat generation system studied here represents a condensing gas boiler. The design temperatures of the space heating system are 50 °C (flow-line) / 35 °C (return-line) at an ambient temperature of -10 °C.

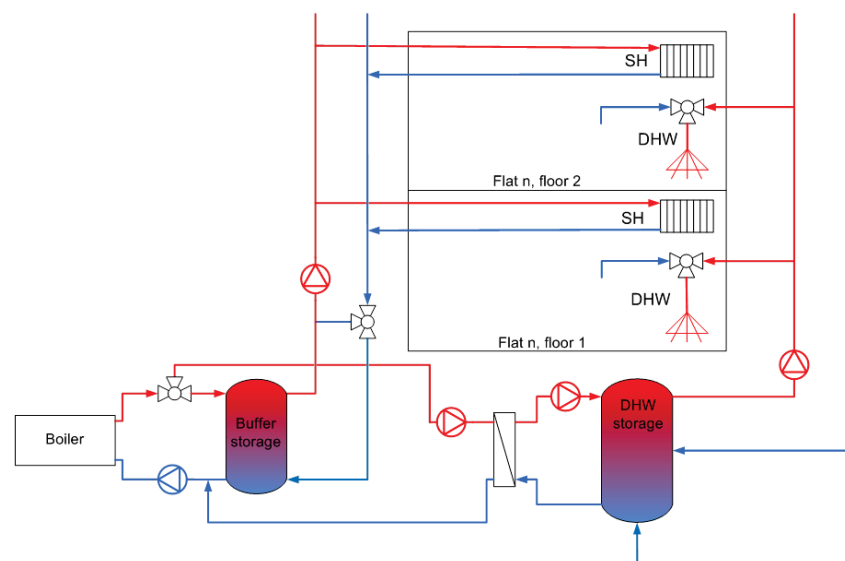

Fig. 1: Four-line pipe network with central heat generation

### Dual-line pipe network (2L)

The second set-up considers a dual-line pipe network as shown in Figure 2. It comprises only one pair of pipes for both DHW and SH supply, which contains heating water. The DHW is then heated up on demand in decentralized heat transfer units, which are installed in every individual flat. Accordingly, the overall fluid temperature in the distribution pipes may be allowed to drop below 60 °C. The heat distribution network must meet a DHW comfort criterion of 45 °C draw temperature. To achieve this securely, the supply temperature is set to 50 °C in the simulation. The advantage of 2L over the 4L pipe network results from the lower forward line temperature, the absence of a central DHW-storage as well as the reduction of overall pipe length. Simplified integration of solar thermal heating technology is another advantage of 2L pipe networks in general. An optimized 2L system variant (2L-opt) allows a further reducing of the pipe network's temperature level by electric backup heaters in the local heat transfer modules of the individual flats. The backup heaters ensure the desired tap water temperature (of 45 °C - in this case). They are arranged after the DHW heat exchanger (compare Figure 2).

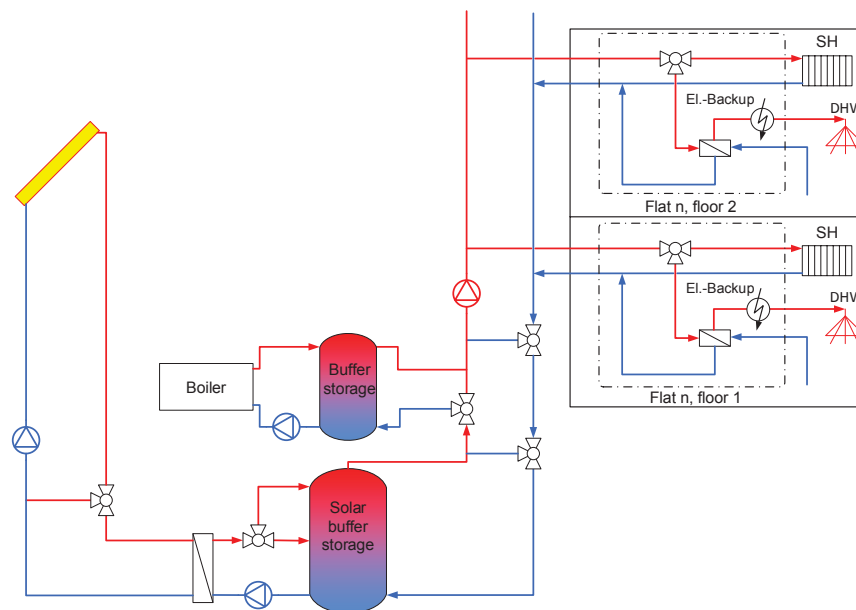

Fig. 2: Dual-line pipe network with central heat generation and integrated solar thermal system

### Dual-line pipe network with decentralized storages

The design of this system is the same as standard 2L systems, but with decentralized buffer storages for DHW preparation. These buffers are assumed in each individual flat. The DHW is prepared on demand (when tapped) by near-by domestic hot water modules, which draw heat from the buffers for this purpose (compare Figure 3).

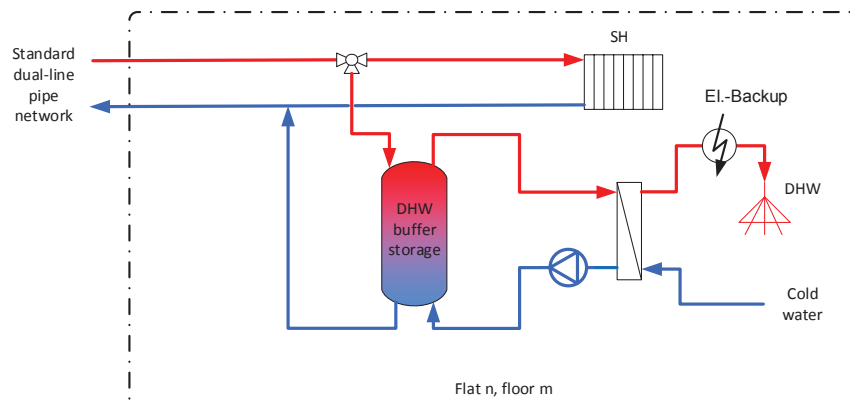
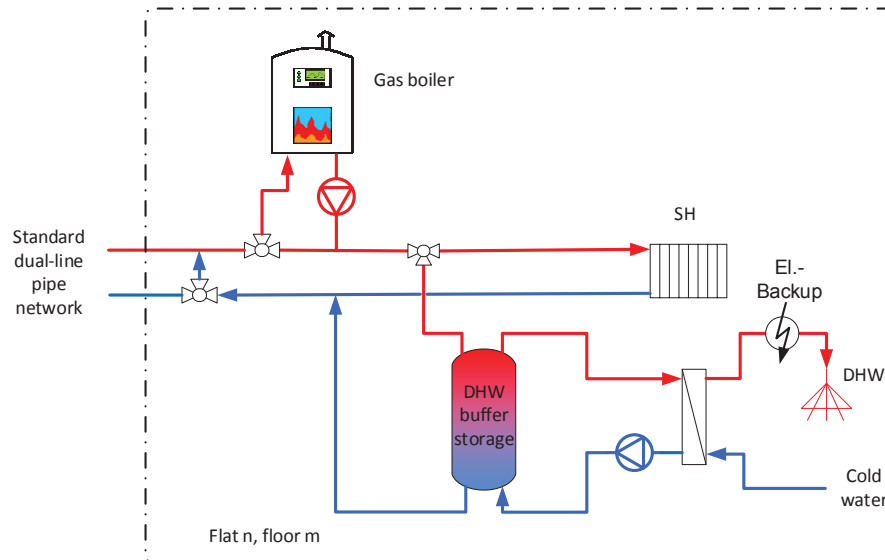

Fig. 3: Dual-line pipe network with decentralized storages in each individual flat

*Dual-line pipe network with decentralized boilers*

Another design approach to reduce distribution-related heat losses is the de-centralization of the heat generation using fossil fuels. In the present model this can be achieved by decentralized gas boilers installed in the individual flats (compare Figure 4). Because of the low-power level of the boilers, decentralized DHW storages (identical with those in the previous system) are necessary to grant for DHW-comfort. For this concept, the only heat distributed from the heat central to the flats is solar heat.



**Fig. 4: Dual-line pipe network with decentralized boilers in each individual flat**

*Dual-line pipe network with decentralized heat pumps*

Another design approach regards decentralized heat pumps for heat generation in the individual flats. The heat pumps are assumed to supply small, localized buffer storages. In contrast to the two previous model designs, the local storages, which contain heating circuit water, do supply heat for both SH and DHW, the latter via DHW modules (compare Figure 5). The model design assumes that the common heat source supplying the heat pumps is produced from geothermal resources through borehole heat exchangers. For this purpose, low-temperature geothermal heat is buffered in a central heat storage from which it is distributed to the individual heat pumps in the flats. In an alternative setting, the central heat supply may also be supported by a solar thermal system. In this case, the central storage keeps also the solar heat.

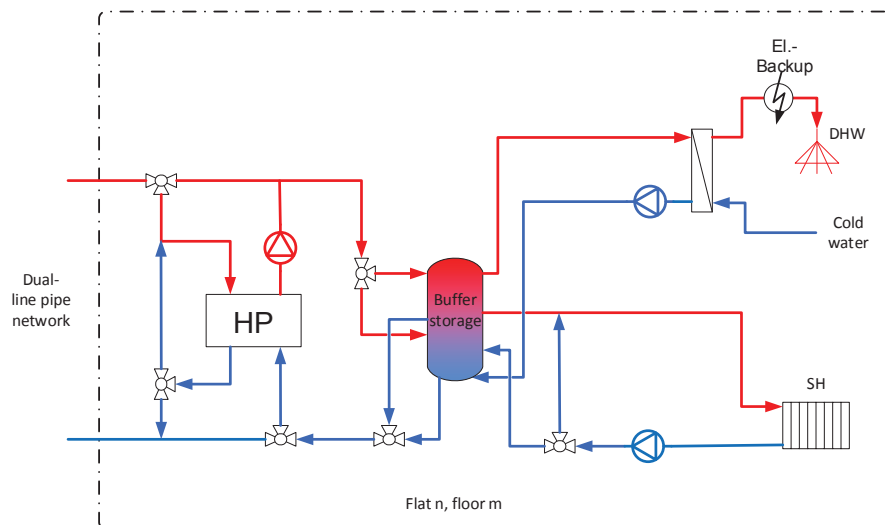

**Fig. 5: Dual-line pipe network with decentralized heat pumps in each individual flat**

#### 4. Results

The results are presented in three separate sections: Firstly, regarding the optimization of the heat distribution network, secondly, regarding the utilization of solar heat and thirdly, regarding the alternative supply routes.

##### *Optimization of the heat distribution network (2L-opt)*

The optimization of the heat distribution network regards the transformation from the common four-line pipe network to the dual-line pipe network, keeping the conventional central gas boiler for heat generation in place. Figure 6 shows the impact of this configuration change on the building's overall heat demand, comparing four situations: (1) an idealized reference system without any heat distribution losses; (2) the four-line and (3) the dual-line systems as described above; (4) a further optimized dual-line pipe network, referred to "2L-opt" in Figure 6. The latter assumes electric backup heaters in the local heat transfer stations of the individual flats, which allows reducing the temperature level in the flow line pipe from 50 °C to 40 °C to further reduce the distribution losses without suffering in DHW comfort.

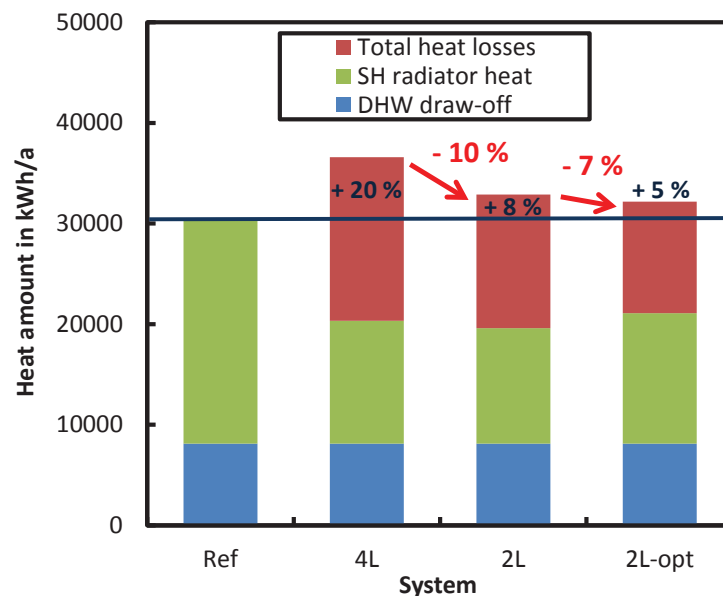

Fig. 6: Impact of distribution pipe network optimization on the buildings heat demand

The conventional 4L system exhibits 20% higher heat demand, than the idealized, loss-less reference system, thus indicating the total optimization potential of the supply design at given room comfort level. The configuration change from 4L to a basic 2L setting reduces the total energy demand by 10 % with respect to the conventional design, but the demand is still 8 % above the idealized reference system. The optimized 2L system allows further reduction by 7 %, resulting into an offset of 5 % above the ideal system. In other words, the reduction potential of the model building is already met to an extent of 75 % by a configuration change of the heat distribution network, without regarding advanced de-centralizing of the entire heat generation system (except for the electric DHW backup heaters). This reduction is the result of minimizing the heat exchanging surface area (from 4L to 2L) and the decreased pipe network temperatures (from 4L via 2L to 2L-opt). Figure 4 provides the details: Unusable heat distribution losses are reduced significantly by the described configuration change such that the distribution efficiency is increased. This efficiency may be judged from the usability of the heat losses, which is defined as the ratio of the usable heat losses of the system and the overall heat losses,

$$\text{Usage factor of losses} = \frac{Q_{\text{loss,use}}}{Q_{\text{loss,total}}} \quad (\text{eq. 1})$$

“Usable” are heat losses from the piping systems, if the heat leaks into the building so as to support the space heating. “Unusable” heat losses lead to higher room temperatures as designed and thus are finally dissipated

to the environment. As of Figure 7, the usability of the heat losses can be increased from 63 to 86 % by the design change from 4L to the 2L-opt setting.

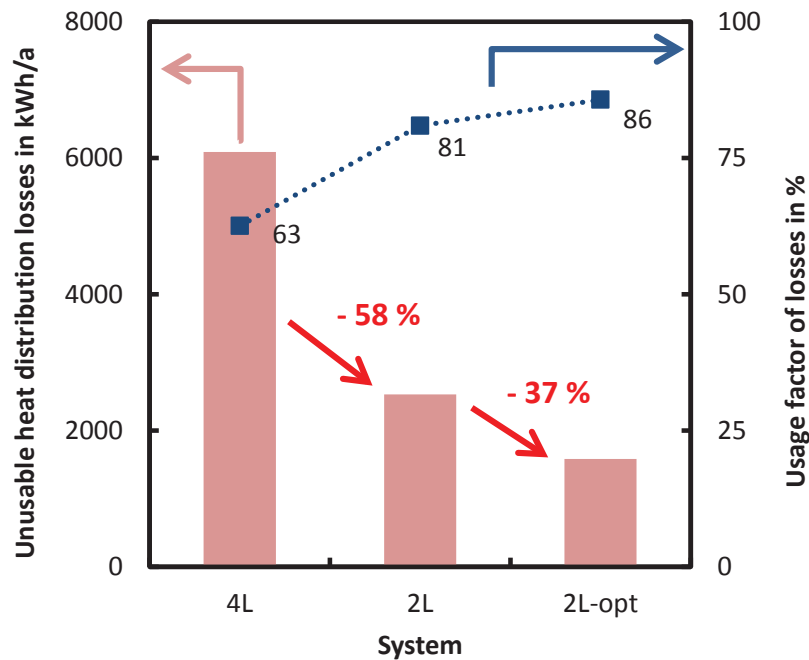

Fig. 7: Impact of the heat distribution network optimization on the usability of heat losses

The remaining unusable heat distribution losses, which mark the heat demand's reduction potential, amount to 1582 kWh or 5 % of the total energy demand according to Figure 6. These results are based on the strong assumption that all inhabitants share the same heating habits (single-zone temperature: 20 °C in all rooms). It may be noted that simulations performed with localized (multi-zone) room set temperatures exhibit even more reduced usability ratios, see Mercker et al. (2016b & 2016c). In non-homogeneously heated buildings the heat distribution losses are expected to be higher (doubling is possible) and their usability lower (even less than 50 %) – All despite this, the present study keeps the assumption of homogenous set temperatures of the rooms for the sake of simplicity (individual living behavior is difficult to predict) as well as comparability. Therefore, the discussed results mark the lower end of the expected spectrum.

#### Utilization of solar heat

The integration of a solar thermal system leads to both decreased fossil energy demand and significant reduction of heat distribution losses covered by fossil energy. Figure 8 indicates how solar radiation and unusable heat distribution losses coincide during the summer months. The coincidence can be used to increase the energy efficiency of heat supply systems.

The reason for the peak of unusable heat losses during summer lies in the fact of missing space heating demand during this period, which might profit from heat losses in a situation of still necessary DHW heat distribution demands. Therefore, 54 % of the total unusable heat losses occur during May to September. Because the solar thermal system has its production maximum during the same period, it is suitable to cover the summer heat demand from solar resources. The model predicts 54 % reduction of fossil energy consumption related to unusable heat distribution losses.

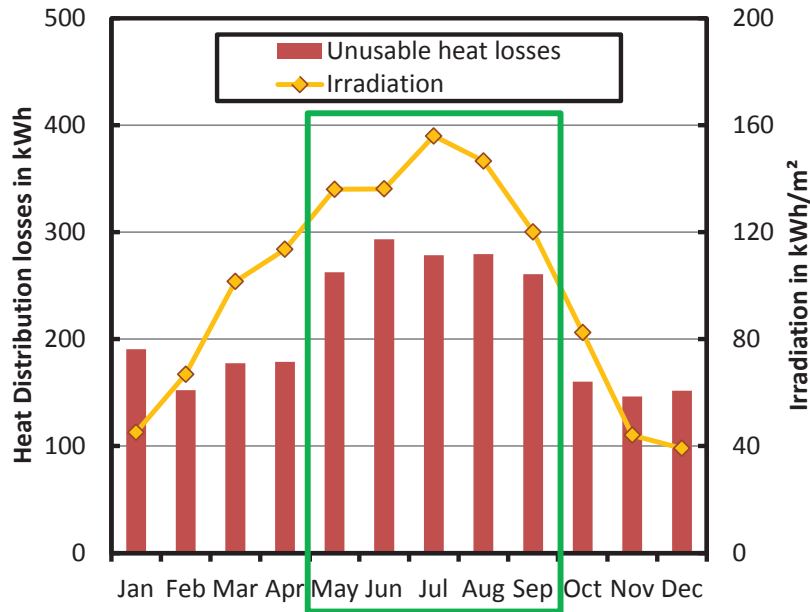

Fig. 8: Comparison of monthly solar irradiation and unusable heat distribution losses of a four-line pipe network

The collector aperture area is calculated with reference to the German guideline VDI 6002-1 (2004). The resulting field size is in the range from 5 to 8 m<sup>2</sup> or 0.3 to 0.5 m<sup>2</sup> per person. Additionally, collector areas of 16, 24 and 32 m<sup>2</sup> have been simulated to investigate the effect of larger solar thermal systems. The solar storage size is set to 50 l/m<sup>2</sup>coll. Table 1 shows the relation of different field sizes to the solar yield (as energy output of the solar storage) and the gained solar coverage of the total heat demand.

Tab. 1: Size comparison of the solar heat systems

Collector area in m <sup>2</sup>	Collector area in m <sup>2</sup> /person	Solar yield in kWh/m <sup>2</sup>	Solar coverage of total heat demand in %
8	0.5	474	12
16	1.0	411	20
24	1.5	350	26
32	2.0	306	30

We see that with a collector field size of 32 m<sup>2</sup>, a solar coverage of the total heat demand of 30 % can be reached, comprising a collector yield of 306 kWh/m<sup>2</sup>. Note that this field size is at least four times larger than the area recommended by the considered guideline VDI 6002-1 (2004).

Figure 9 shows both, the monthly heat demand, distinguished between SH, DHW and distribution losses, and the monthly solar yield for the four examined collector field sizes in one diagram. Both y-axis are limited to 2000 kWh, although the monthly heat demand (which is the sum of total heat losses, DHW-draw-off and radiator heat) exceeds 2000 kWh from November to March.

We conclude from this figure, that the total heat demand of the model building during May to September may be covered by a solar thermal system with a minimal collector area of 32 m<sup>2</sup>. A 16 m<sup>2</sup> system still allows a (nearly) 100% solar fraction within July and August. The 8 m<sup>2</sup> system, designed according to the VDI 6002-1 (2004), however, only just covers the DHW demand, but nothing of the heat distribution losses.

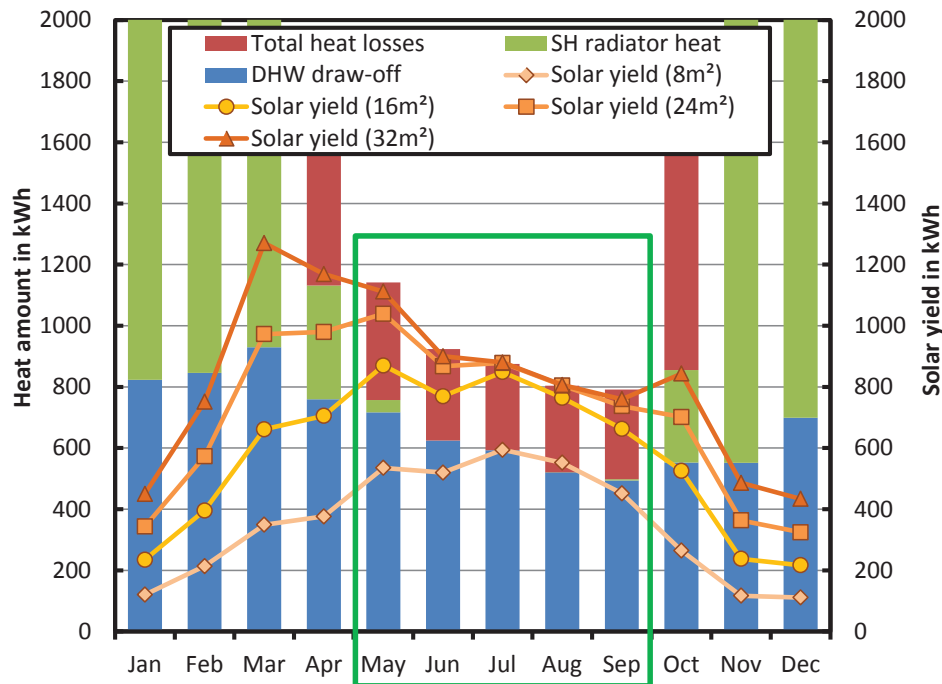

Fig. 9: Comparison of the monthly heat demand of an optimized dual-line pipe network and collector yield reached by different field sizes

Using a suitably scaled solar thermal system, the total heat demand – including distribution losses – may be completely supplied during May to September and the boiler may be turned off during this period. This saves ca. 54 % of the formerly fossil-fuel covered unusable heat losses, as well as the standby losses of the boiler and related inefficient part load operation during the summer season. In sum, this means that the remaining pipe network induced optimization potential for the building’s heat demand of 5 % (or 1582 kWh/a according to concept 2L-opt) is reduced further to 2 % (or 728 kWh/a).

The alternative approach with the integration of electric backup heaters for DHW supply into the 2L system, installed in the local heat transfer stations of individual flats, allows the boiler to be turned off during the summer months without suffering a loss in DHW comfort (as with the design before), but the solar thermal systems may be designed smaller. The model predicts that in this case the solar thermal system may be down-sized to 8 m<sup>2</sup> collector area. Because a down-size of the solar thermal system also reduces the solar yield during spring, autumn and winter, this design approach incorporates less fossil-fuel savings, than the design without electricity supply, but larger solar yields than discussed before. Table 2 shows that with an enlarged solar collector from 8 to 16 m<sup>2</sup>, the electric energy will be reduced by two thirds. With 32 m<sup>2</sup>, electric heating is nearly negligible. Note, that the lower pipe network’s temperature in summer leads to significantly higher collector yields at smaller collector areas.

Tab. 2: Heat generation and energy demands for different collector field sizes in the 2L-opt system

Collector area in m <sup>2</sup>	Solar yield in kWh/a	Electricity consumption in kWh/a	Gas consumption in kWh/a
8	4210	1156	31174
16	6891	399	29671
24	8586	147	28276
32	9869	65	27066

### Alternative systems

The last studied design approach to minimize the unusable part of the heat distribution losses regards fully-decentralized heat generation. This situation is modelled concerning decentralized boilers or heat pumps in



individual flats with and without DHW storage tanks, see Section 3. Integration of local storages allows partial downtimes of the building-wide heat distribution network while still maintaining DHW comfort. The model regards nightly (11.00 pm to 5.30 am) downtimes of the central heat supply for this purpose. The results show that the respective distribution losses are avoided indeed. However, the decentralized storages incorporate increased heat leakage rates, thus counteracting the overall heat loss balance. In sum, losses of the storages exceed the savings of heat losses of the heat distribution network.

Figure 7 shows the total heat distribution losses of the examined systems and the respective usage factors. The diagram confirms the high loss-reduction potential of a 4L to 2L configuration change and the subsequent system optimization of Figure 6. Among the studied decentralized designs, the system with decentralized boilers exhibits lowest overall heat losses. The overall reduction potential of this design is comparable to the optimized 2L system, but the usage factors of the 2L-opt design is significantly higher: Heat leakage from commonly insulated DHW storages in the decentralized boiler system are significant but can be utilized for SH of the flats only during the heating season. The simulations show that the losses during summer are large enough to even counterbalance the annual usage factor below the level of the competing 2L-opt design.

The system design comprising decentralized heat pumps exhibits higher losses because the decentralized storage volumes for combined DHW and SH storage are two times larger than DHW-only storages. Larger storage volumes are necessary for the operation of the small heat pumps (2.5 kW condenser power in the present study).

To summarize, the simulation study suggests that decentralized storages should be avoided because of their significant heat loss rates, which may be utilized for space heating only partly during the course of the year. In specific design cases which allow avoiding decentralized storages, however, such de-centralized solutions are expected to be more efficient than centralized ones from the perspective of heat-loss reduction.

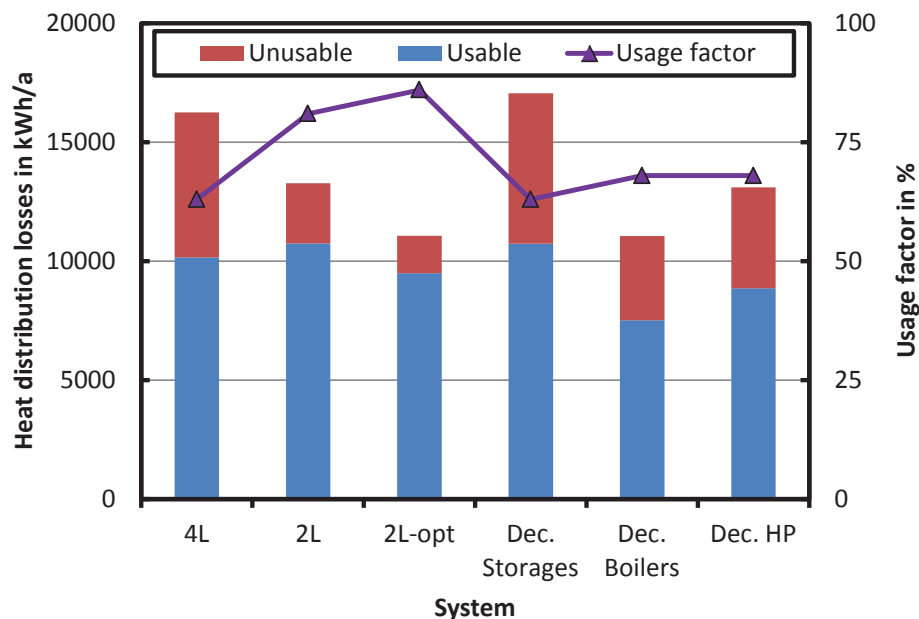

Fig. 10: Comparison of heat distribution losses and the respective usage factor for the studied systems.

The perspective of energy demand of the studied solar designs is provided in Figure 11, specifying both the final energy demand including losses (by columns) and the primary energy demand (by plot lines). The latter takes into account three different primary energy factors for the electricity part: 3.0 for fossil-based electric energy (EnEV 2002), 2.4 for the electric energy mix of Germany in 2015 (EnEV 2014) and 1.8 for the same mix as predicted for 2016 (EnEV 2016). All design cases regard a solar thermal system with 32 m<sup>2</sup> collector area.

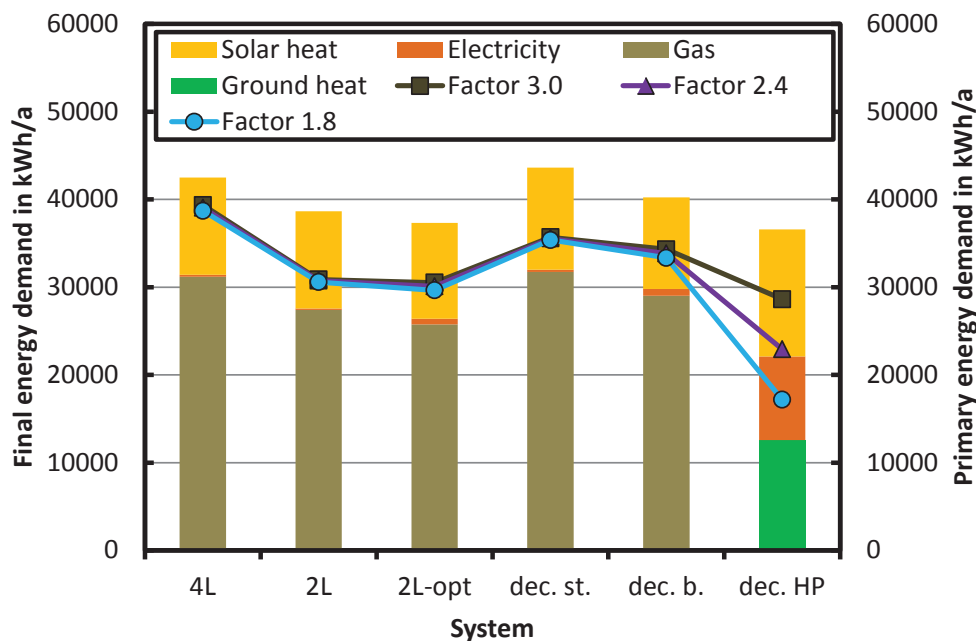

Fig. 11: Comparison of the final and primary energy demand of different systems

The solar thermal supply share is almost the same for all of studied model designs, except for the system with decentralized heat pumps. Here the solar share is significantly higher (ca. + 31 %), than for the other systems. The reason for this observation is that the solar heat can additionally be used indirectly – as a heat source for the heat pump (both, ground heat exchangers and solar collectors are supplying the same central heat storage). In fact, the direct use of the solar energy for DHW or SH is even lower than in other designs. The indirect integration route also incorporates the advantage of low-temperature solar energy production, which also allows using cheaper collector types (e.g. uncovered collectors).

Regarding the final energy demand of the studied systems the optimized dual-line pipe network shows the smallest demand among the fossil supplied designs. The system with decentralized storages has the highest demand owing to the heat losses of the storages. Designs with decentralized boilers have slightly higher final energy demands than the 2L system. The decentralized heat pump system has a lower final energy demand than the optimized dual-line pipe network. The reason for that is the further reduction of distribution heat losses, due to partial operation of the pipe network below indoor temperature even heat gains occur, because the ground heat exchangers deliver heat at an average temperature of 7 °C.

A comparison of the primary energy demands of the studied designs leads to the result that the design comprising decentralized heat pumps has the lowest demand, because it can benefit from the primary factor Germany's electric energy mix. Next to it is the design comprising the optimized 2L configuration.

## 5. Conclusion

Heat distribution losses have a significant impact on the heat demand of well insulated multi-family houses and must be regarded in situations of both, new constructions and system retrofits. Essential for decreasing the heat distribution losses is to minimize the length of pipe ducts and to lower the distribution net's temperature. Both can be realized by choosing a dual-line pipe network instead of a common four-line pipe network. When electric backup heaters are installed, the system's efficiency can be further increased by an additional reduction of the flow line temperatures.

A well-designed dual-line pipe network is even more effective regarding distribution heat losses as well as final and primary energy demand than systems with decentralized boilers, at least when they also have decentralized storages.

Solar thermal systems are of great advantage both to increase the system's effectiveness and to lower the system's final and primary energy demand. But it is of high importance to scale the system to the appropriate size. Common guidelines in Germany recommend field sizes that are quite small. This modelling study shows that such design is not able to cover the building's heat demand including distribution losses even in July and August. Thus, under energetic aspects, scaling the collector field to a bigger size is reasonable. This is because most of the system's unusable heat losses are occurring during the summer months because of their low usability in this period. With a large scaled solar thermal system of  $2 \text{ m}^2_{\text{coll}}$  per person, the heat demand can be covered completely by solar thermal energy from May to September and the boiler can be switched off during this time. By that, a total of 54 % of the overall unusable losses can be covered by solar heat. The same effect can be reached with smaller scales of the solar thermal system if electric backup heaters are installed in the heat transfer stations to compensate the lack of solar heat in case of a boiler that is switched off in summer.

Compared to a common four-line pipe network, an optimized dual-line pipe network with a sufficiently scaled solar thermal system ( $2 \text{ m}^2_{\text{coll}}$  per person) reduces the unusable heat distribution losses by 87 %, which leaves a potential for further optimizations of only 2 % of the total heat demand. Doing that, the building's heat demand is reduced by 12 %. The gas consumption is reduced by 39 % and the primary energy demand (factor 2.4 for electricity) by 36 %.

Using a heat pump for heat generation grants better use of solar energy and the lowest energy demand (regarding final and primary energy) of all investigated systems. Though not examined in this study, it can be assumed that an optimized dual-line pipe network in combination with a central heat pump and a suitable solar thermal system would be the most effective system in every aspect. Further research work is necessary to validate this.

## 6. Acknowledgement

The project MFH-re-Net (FKZ 03ET1194A) is funded by the German Federal Ministry for Economic Affairs and Energy based on a decision of the German Federal Parliament. Project partners of the ISFH are *Delta Systemtechnik GmbH*, situated in Celle, *ProKlima, Heimkehr Wohnungsgenossenschaft eG*, and *Gesellschaft für Bauen und Wohnen Hannover mbH (GBH)*, all situated in Hannover. The authors are grateful for the financial support. The content of this paper is in the responsibility of the authors. Moreover, the authors would like to express their appreciation to Prof. Dr.-Ing. Oliver Kastner for the detailed and valuable review of this paper.

## 7. References

- Greller, M. et al., 2010. Universelle Energiekennzahlen für Deutschland. Bauphysik 32 (published in German)
- EnEV, 2014. Verordnung über energiesparenden Wärmeschutz und energiesparende Anlagentechnik bei Gebäuden (Energieeinsparverordnung - EnEV), URL (abgerufen am 30.09.2016): [http://www.enev-online.com/enev\\_2014\\_volltext/index.htm](http://www.enev-online.com/enev_2014_volltext/index.htm)
- Jahnke, K. et al., 2015. Wirksam sanieren: Chancen für den Klimaschutz. Co2online gemeinnützige GmbH, Berlin (published in German)
- Majcen, D.; Itard, L.; Visscher, H., 2013. Actual and theoretical gas consumption in Dutch dwellings: What causes the difference? Energy Policy 61 460-471
- Mercker, O. et al., 2016a. Ansätze zur Reduktion konventionell gedeckter Verteilverluste in solar unterstützten Mehrfamilienhäusern. Tagung Gleisdorf SOLAR 2016, Gleisdorf (published in German)
- Mercker, O. et al., 2016b. Bestimmung, Bewertung und Reduktion von Wärmeverteilverlusten in Mehrfamilienhäusern. Tagung CESBP/BauSIM 2016, Dresden (published in German)

Mercker, O. et al., 2016c. Wie sind zentrale Wärmeversorgungssysteme in hochgedämmten Gebäuden zu gestalten? Ausführliches Skript zur OTTI Solarthermie Tagung 2016, Bad Staffelstein (published in German)

Streicher, W. et al., 2003 (revised February 2007): Analysis of System Reports of Task 26 for Sensitivity of Parameters - A Report of IEA SHC - Task 26: Solar Combisystems, Institute of Thermal Engineering, Graz University of Technology, Graz

Verein Deutscher Ingenieure, 2004. VDI 6002 Blatt 1 – Solar heating for domestic water. General principles, system technology and use in residential buildings. Düsseldorf

Wolff, D. et al., 2012: Einfluss der Verteilungsverluste bei der energetischen Modernisierung von Mehrfamilienhäusern – Analyse und Ableitung von Optimierungsmaßnahmen. Projekt im Auftrag des proKlima energy-Fonds, Hannover/Braunschweig/Wolfenbüttel

