



## Conference Proceedings

ASES National Solar Conference 2019

Minneapolis, Minnesota August 5-9, 2019

### A Study on the Thermal Energy Storage System Using Multiple PCMs

Omer S. Elsanusi<sup>1</sup>, Emmanuel C. Nsofor<sup>1</sup>

<sup>1</sup> Department of Mechanical Engineering and Energy Processes, Southern Illinois University  
Carbondale, Carbondale, IL, (USA)

oelsanusi@siu.edu

#### Abstract

Application of Phase Change Materials (PCMs) for energy storage has been found to exhibit high potential due to the high energy storing capacity. This study investigated the performance of multiple PCMs in a number of energy storage systems. The effects of conduction and natural convection on these systems were also studied. Numerical simulations based on the conservation equations were conducted on the defined geometries. It was found that natural convection has significant positive effects on the heat transfer in these systems. It was also found that application of multiple PCMs generally enhances performance. However, different effects were observed on the heat transfer mechanisms. The parallel configuration enhances conduction but suppresses convection while the series configuration does the opposite. It was also found that the vertical orientation enhances convection more than the horizontal orientation for the multiple PCMs configurations. Energy storage with the series configuration in vertical orientation was found to be superior with 47% and 60% reduction in complete melting time respectively, compared to the single configuration in vertical orientation and to the single and series configurations (horizontal and vertical) in the conduction only case.

Keywords: *Phase Change Materials, Renewable Energy, Heat Transfer*

---

#### 1. Introduction

Renewable energy sources such as solar, wind and hydro have the potential to address the energy challenges facing the world. The challenges include continued increase in energy consumption and demand due to population growth and the changing ways of life. This demand increase is faced with expectations of fossil fuels depletion and the environmental hazards associated with their extraction, transportation and consumption. One major obstacle that all renewable energy sources have to overcome is their inherited fluctuations in nature. This is why it is crucial to develop efficient means of energy storage.

Considering solar energy, thermal energy storage (TES) presents high potential and could be a very reasonable means for addressing the fluctuation issue. TES systems are classified into three methods namely sensible heat, latent heat and thermochemical storage methods [1]. Latent heat storage method has the advantage of the high energy storing density available in Phase Change Materials (PCMs). However, there are challenges

that need to be addressed in order to efficiently apply its use on commercial scales. PCMs suffer when it comes to thermal conductivity. Their low thermal conductivity leads to low heat transfer rates and hence to slow energy storage and recovery processes.

One way to overcome this limitation, is by developing new phase change composites with the aid of additives. Potential additives that have been studied include porous graphite and metallic matrices, dispersing metal particles, carbon fibers and nanotube amongst others. Poly vinyl Pyrrolidone (PVP) was used as a dispersing additive to enhance multi walled carbon nanotube MWCNT, graphite and graphene dispersion in liquid Steric Acid (SA). It was found that PVP provides good dispersion of additives in SA. It was stated [2] that as the percentage of additives was increased to 5%, they have a strong influence on the melting point, freezing point and latent heat of SA and reduced heat storage capacity due to reducing steric acid mass in these cases. Nano magnetite ( $\text{Fe}_3\text{O}_4$ ) particles were added at different ratios to enhance the common PCM paraffin. 10% increment in heat storage capacity of Paraffin with melting point range of 46 to 48°C was reported with the conclusion that further investigation and analysis are needed to determine the thermal stability and thermal conductivity of these composites [3]. According to Zabalegui et al. [4], there is a disadvantage of using nanoparticles to enhance PCMs' thermal conductivity as it was reported that reduction of latent heat of fusion occurred in response to the dispersion of MWCNT in paraffin. It was stated that Brownian motion, particle clustering and interfacial liquid layering are possibly the causes for this reduction. This points out that adding nanoparticles in PCMs may not provide significant enhancement in TES performance since thermal conductivity enhancement is faced with reduction in latent heat of fusion.

Other methods including the use of multiple PCMs are being investigated to enhance the heat transfer and hence the performance of these systems. The use of cascaded PCM of D-Mannitol and Hydroquinone has been evaluated. These PCMs have melting temperatures in the range of 150 – 200°C. It was found that this configuration produces significant enhancement of about 19.4 % compared to the single PCM configuration. Moreover, the temperature difference in the heat transfer fluid between inlet and outlet was more uniform [5]. The effects of the number of PCMs used, the melting temperature difference between them and their mass ratios on the performance were investigated. It was reported that multi PCM configuration enhances TES performance more as the number of stages increases. However, this enhancement wasn't significant with applying more than three stages [6]. On the other hand, larger melting temperature difference between PCMs was found to enhance the performance significantly. Wang et al. [7] found that m-PCMs with unequal mass ratios produce better enhancement.

## 2. Materials and Methods

The method used in this study for investigating the performance of multiple families of PCMs in different configurations and orientations was inspired by the fact that heat transfer is directly proportional to temperature difference.

### 2.1 Geometry and Properties

Fig. 1 illustrates the PCM container with a working fluid circulating in the immersed piping. Multiple-PCMs under the arrangements were studied to understand the heat transfer and melting processes in the setup and

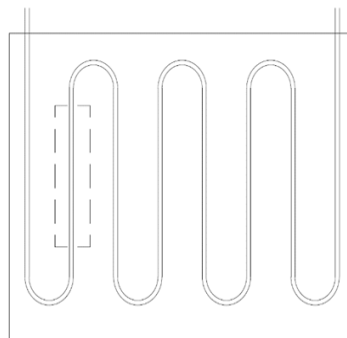

Fig. 1: PCM container with circulating working fluid

investigate the system performance. A small segment of the piping is considered as shown by the dashed line. This segment is modeled as a concentric pipe. The inner pipe that carries the working fluid has an inside radius ( $r_i$ ) of 7 mm and an outside radius ( $r_t$ ) of 8 mm. The outer radius surrounding the PCMs ( $r_o$ ) is 35 mm. This section of the pipe is 500 mm long. These dimensions are chosen to enable model validation with the study by Fornarelli et al. [8]. Under the assumption of axisymmetric conditions (except for the third case as will be discussed), a 2D model is considered. Three PCMs were considered with melting temperatures that range from 430 to 520 K, thermal conductivities from 0.4 to 0.5 W/m K, specific heats from 1400 to 1650 J/kg K and densities from 1500 to 2000 Kg/m<sup>3</sup>.

Three configurations of PCM were studied namely: (a) Single PCM configuration, (b) M-PCMs in series configuration and (c) M-PCMs in parallel configuration. These configurations describe how single or m-PCMs occupy the PCM container as shown in figure 2. The PCMs were arranged in the order of their melting points from high to low.

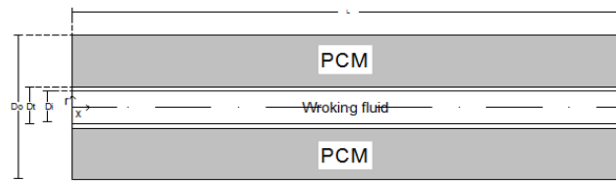

Fig. 2: Geometry under investigation

## 2.2 Mathematical Model

Heat transfer and fluid dynamics of this setup are characterized by velocity, temperature and liquid fraction of the working fluid and phase change materials. They are governed by the mass conservation equation, the momentum conservation equations and the energy equation. The energy equation is considered in the enthalpy form to account for the latent heat of melting as follows:

$$H = h + \Delta H \quad (\text{eq. 1})$$

$$h = h_{ref} + \int_{T_{ref}}^T c_p dT \quad (\text{eq. 2})$$

where H is Total enthalpy, h is sensible enthalpy and  $\Delta H$  is latent enthalpy evaluated as:

$$\Delta H = \gamma L \quad (\text{eq. 3})$$

where  $\gamma$  is the liquid fraction that has melted of the PCM. It varies from 0 to 1 depending on temperature variation compared to the melting temperatures.

A number of boundary conditions were implemented to account for the different configurations under study and for the different properties that each domain has. In the Single PCM configuration, thermophysical properties of the first PCM was applied to the whole PCM domain. In the M-PCMs - parallel arrangement, three PCMs surrounding each other fill three sections of the PCM domain while in the M-PCMs - in series configuration, the three PCMs sections are arranged next to each other. Properties of each PCM was applied to its section.

The working fluid flows in the inner pipe with constant inlet velocity of 0.9 m/s and temperature of 523.13 K and exits with fully developed flow characteristics. It is modeled as a transient laminar incompressible flow. As it flows, heat transfer occurs through the pipe wall and towards PCMs due to the temperature difference. PCMs are assumed to have an initial temperature of 423.13 k. Other assumptions are: No-slip boundary conditions, negligible viscous dissipation and no heat loss to the surroundings. All the thermophysical properties are constant except for the working fluid temperature dependent properties and the PCM's density

where Boussinesq approximation is used to model variations in the momentum equation resulting from density variations in fluids.

### 2.3 Computational Method

The governing equations were solved in the specified domain using transient numerical simulation with the aid of ANSYS FLUENT software that applies the finite volume method in discretized domain to solve the partial differential equations. To account for the PCMs melting, the “Solidification & Melting” model was used that considers the energy equation in the enthalpy form to account for the latent heat of melting. Simulation was accomplished by using the “Semi-Implicit Method for Pressure Linked Equations” “SIMPLE” algorithm and the pressure-based solver.

#### Model validation:

In order to test the validity of the developed model, a comparison with the study conducted by Fornarelli et al. [8] was done. That study investigated the use of phase change materials for high temperature applications using a shell and tube setup where PCM is contained in a cylindrical tank with heat transfer fluid flowing in an immersed steel tube from top to bottom. It was found in that study that natural convection enhances melting time considerably. This comparison considered the same exact geometry and boundary and initial conditions. Figure 3 shows comparison of the results obtained from the current model and that study at the same location. The temperature variation with time from both models are in reasonable agreement. The only disagreement between the models can be seen at the first half hour range. The reason for this is the fact that the temperature of the working fluid started at 423.13K and increased linearly until it reached 523.13K after 30 minutes in Fornarelli's study but this study considers the temperature of the working fluid to be 523.13 from start.

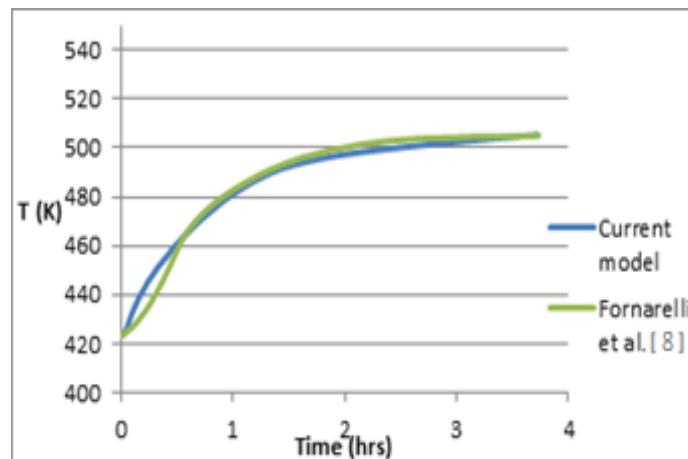

Fig. 3: Temperature variation with time at a specific location using current model and Fornarelli et al. [8]

## 3. Results and Discussion

In this section, contours of liquid fraction are presented to illustrate the melting process of the single PCM configuration compared to the m-PCMs configurations. Effects of the m-PCMs configuration on the heat transfer mechanisms are discussed.

### 3.1 Conduction heat transfer only (Case 1)

To investigate the performance of the different configurations based specifically on conduction heat transfer, natural convection is neglected. Since conduction heat transfer is not dependent on the direction of the gravity, this case represents both vertical and horizontal orientations. The indicated configurations of single, m-PCMs in series and in parallel were studied through numerical simulations. Single PCM configuration was tested first and was considered a base line on which comparisons with other configurations were made. Contours

representing melted PCMs versus time were plotted. Figure 4 shows liquid fraction contours for the single PCM configuration. It can be seen that the PCM is in solid state initially and as the working fluid starts flowing in the inner pipe, it starts heating up the walls of the pipe and consequently heats up the PCM until they reach their melting point where the melting process starts to take place. As time progresses, the melted layer grows by absorbing more heat from the working fluid. It can be seen how the low thermal conductivity affects this process negatively. The first layer adjacent to the wall melts relatively fast. However, the melting progress gets slower as the distance from the solid wall increases. One other reason for this is that heat transfer is directly proportional to temperature difference and as heat is transferred from the working fluid, there is a drop-in temperature difference. So, the second and third configurations come into the picture with m-PCMs with different melting temperatures (lower as the distance from inlet or from solid wall increases). The series configuration presented a promising start where the melting front started traveling faster than in the single PCM configuration. However, it slowed down toward the end with no significant overall enhancement. On the other hand, the parallel configuration presented significant enhancement and more consistent heat transfer performance. The melting front traveled with more uniform speed. When only conduction heat transfer considered, this configuration is found to reduce complete melting time by about 40% compared to the single PCM configuration.

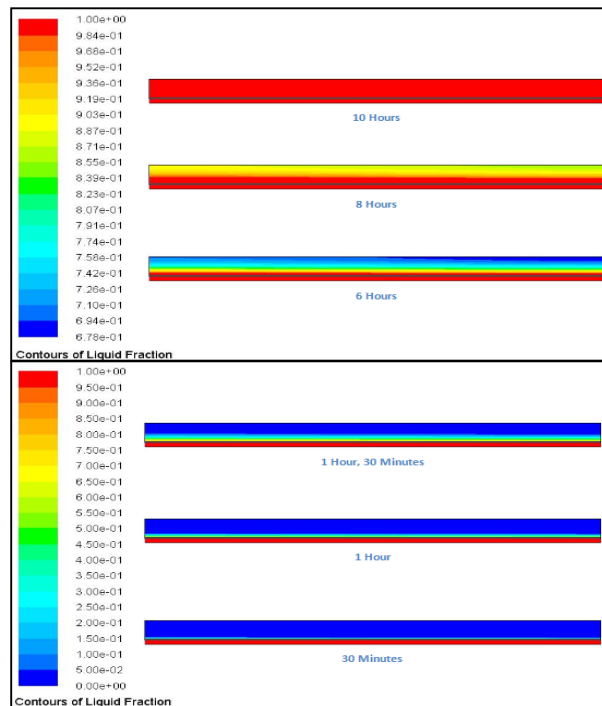

Fig. 4: Single PCM configuration – case 1

### 3.2 Conduction and natural convection in vertical orientation (Case 2)

This case considers both conduction and natural convection heat transfer mechanisms when the system is vertically oriented. Like case 1, contours of the liquid fraction were plotted. Examining the configurations, it was found that natural convection affects the heat transfer and the melted layer growth with clear reduction in melting time. Once a portion of the PCMs melts, it starts floating up. This circulation boosts the heat transfer. Figure 5 shows the series m-PCMS configuration in case 2 where huge enhancement is observed. This is about 47% reduction in complete melting time compared to the single PCM configuration in vertical orientation and about 60% reduction compared to case 1 (series configuration with conduction only). On the other hand, the parallel configuration in case 2 was found to perform slightly better than the single configuration but not as good as the series one with about 22% reduction in complete melting time compared to the single PCM configuration in vertical orientation. It also does not present significant enhancement over the parallel configuration in case 1 (less than 3% reduction in melting time). Moreover, comparing the series and parallel

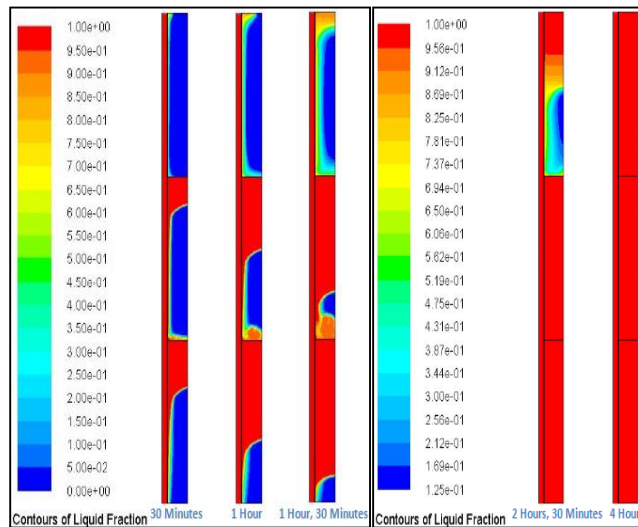

Fig. 5: M-PCMS in series configuration – case 2

configurations of both case 1 and case 2, they present opposite indications; in case 1, the parallel configuration was superior to the series configuration (40% vs 0% reduction in melting time compared to the single PCM1 configuration); while the opposite is observed in case 2.

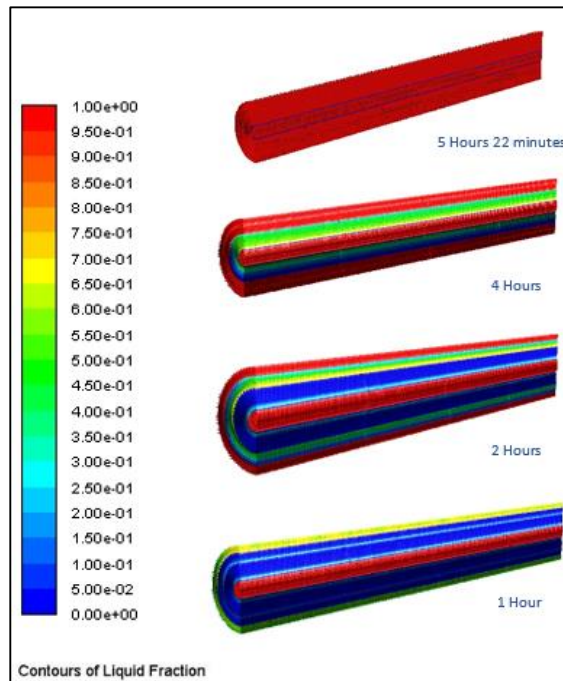

Fig. 6: M-PCMS parallel configuration – case 3

### 3.3 Conduction and natural convection in horizontal orientation (Case 3)

The axisymmetric assumption is invalid in this case due to gravitational force direction. The bottom part of the PCM containing tube have lower natural convection heat transfer rate compared to the top part as the pipe wall will suppress the buoyancy motion. This led to modeling this case in 3 dimensions. However, instead of modeling the complete concentric pipe, only half of it is considered due to symmetry., Figure 6 shows the liquid fraction contours for the parallel m-PCMs configuration in case 3. As was expected, the upper part of the PCM container has faster melting rate due to higher natural convection heat transfer rate compared to the lower part in all the three configurations. It was observed that both the series and the parallel configurations

enhanced the performance compared to the single PCM configuration (about 15.5% and 9.3% reduction in the melting time respectively). However, this enhancement is not as significant as the situation in case 2 (vertical orientation). On the other hand, the single PCM configuration in case 3 performs significantly better compared to both case 1 and case 2 (which shows about 41% and 21% reduction in melting time respectively).

#### 4. Conclusion

This study investigated the performance of using multiple PCMs in different configurations and orientations. A discussion of the effects of conduction and natural convection heat transfer were studied. Results show that natural convection has a significant positive effect on the heat transfer characteristics of the systems. It was also found that the application of multiple PCMs generally enhances performance. However, they have different effects on the heat transfer mechanisms depending on configuration and orientation. Parallel configuration enhances conduction but suppresses natural convection while series does the opposite. It was also found that vertical orientation enhances natural convection more than the horizontal orientation for the multiple PCMs configurations. Energy storage with the series configuration in vertical orientation was found to be superior with 47% and 60% reduction in complete melting time respectively, compared to the single configuration in vertical orientation and the single and series configurations (horizontal and vertical) in the conduction only case.

#### Acknowledgements

This work used the Extreme Science and Engineering Discovery Environment (XSEDE), which is supported by National Science Foundation grant number ACI-1548562. Specifically, it used the Bridges system, which is supported by NSF award number ACI-1445606, at the Pittsburgh Supercomputing Center (PSC).

#### 5. References

1. Dheep, G., Sreekumar, A., 2014. Influence of nanomaterials on properties of latent heat solar thermal energy storage materials – A review. *Energy Conversion and Management*. 83, 133-147.
2. Li, T., Lee, J., Wang, R., Kang, Y., 2014. Heat transfer characteristics of phase change nanocomposite materials for thermal energy storage application. *International Journal of Heat and Mass Transfer*. 75.
3. Sahan, N., Paksoy, H., 2014. Thermal enhancement of paraffin as a phase change material with nanomagnetite. *Solar Energy Materials & Solar Cells*. 126.
4. Zabalegui, A., Lokapur, D., Lee, H., 2014. Nanofluid PCMs for thermal energy storage: Latent heat reduction mechanisms and a numerical study of effective thermal storage performance. *International Journal of Heat and Mass Transfer*. 78, 1145-1154.
5. Peiro, G., Gasia, J., Miro, L., Cabeza, J., 2015. Experimental evaluation at pilot plant scale of multiple PCMs (cascaded) vs. single PCM configuration for thermal energy storage. *Renewable Energy*. 83, 729-736.
6. Aldoss, T., Rhman, M., 2014. Comparison between the single-PCM and multi-PCM thermal energy storage design. *Energy Conversion and Management*. 83, 79-87.
7. Wang, P., Wang, X., Huang, Y., Li, C., Peng, Z., Ding, Y., 2015. Thermal energy charging behaviour of a heat exchange device with a zigzag plate configuration containing multi-phase-change-materials (m-PCMs). *Applied Energy*. 142, 328-336.
8. Fornarelli, F., Camporeale, S. M., Fortunato, B., Torresi, M., Oresta, P., Magliocchetti, L., Miliozzi, A., Santo, G., 2016. CFD analysis of melting process in a shell-and-tube latent heat storage for concentrated solar power plants. *Applied Energy*. 164, 711-722.