

DOMESTIC SOLAR/HEAT PUMP HEATING SYSTEMS WITH LOW AND HIGH EFFICIENCY COLLECTORS IN MEDITERRANEAN AREAS.

Andreu Moià Pol¹, Miquel Alomar Barceló, Ramon Pujol Nadal, Víctor Martínez Moll,

¹ University of Balearic Islands, Physics department, P. Mallorca (Spain)

1. Abstract

Recently systems that combine solar thermal technology and heat pumps have been marketed to heat houses and produce domestic hot water. This new combination of technologies is a welcome advancement, and need to be improved in the configuration. These systems will be cleaner as long as the electricity will improve the renewable energy fraction and they improve its efficiency. In Mediterranean areas, where there are less months of heating, the solar thermal systems for heating have a several months with overheating; this fact is an obstacle for the designers and the users. The combination of solar-thermal collectors and heat pumps provides interesting possibilities for innovative and energy efficient heating systems with a high fraction of solar energy. Despite its high cost these systems are gaining more and more importance due to the rising cost of the limited fossil resources. Several configurations of solar systems have been studied. Some of them use cheap collectors that make the investment more attractive.

2. Introduction

The functionality of these systems can lead to special operating conditions which significantly differ from conditions in standard solar systems, e.g. low collector temperatures below the dew point.

The cooler months when the external temperature is below 7 °C, geothermal heat pump systems have a higher efficiency than standard heat pumps. The solar systems with water-water heat pump with a big storage tank can have as well a similar efficiency than the geothermal ones.

The most efficient system consists in using geothermal heat pumps in a closed loop circuit, but it's one of the most expensive configurations, because it needs a big surface of pipes for the heat transfer with the ground. The biggest investment is the excavation (horizontal or vertical). The open loop systems are cheaper but have more barriers (environmental and jurisdictional).

One interesting combination is for houses with big storage water tank or swimming pool, where we can save the buffer storage tank using the isolated pool or tank. There are various solar pool heating systems available, using high or low efficiency collectors. These systems cost little to run - the main cost is the electricity for the pump. Over the life of the system, the total cost will end up being cheaper than systems that use big storage tanks and close to that of the geothermal devices.

In Mediterranean areas many houses have a pool or a rain storage tank; in fact a lot of municipal regulations obligate to have such tanks for family houses. Many of the houses with swimming pool have solar collectors for its use it in autumn months. This kind of houses can take profit of the solar collectors all the year, without overheating. The heat can be dumped into a swimming pool in autumn months, and use the swimming pool like a big buffer tank in the cooler days, with enough storage to store during the cloudy days. This pool will need to be aisled and covered to avoid heat losses.

3. Configurations of the solar HP heating systems

As the feasibility of a solar system depends on its fraction of primary energy saving, different plant configurations, including different elements, are proposed according to the solar collector efficiency and heat pump efficiency to see the optimum system with less energy consumption.

The basic reference system includes the minimum solar collector area to partly meet DHW energy demands of the house, between 60 and 95% depending on the climatic zone and on the building demand, according to the criterion given at the Spanish Energy Saving Basic Document (DB HE).

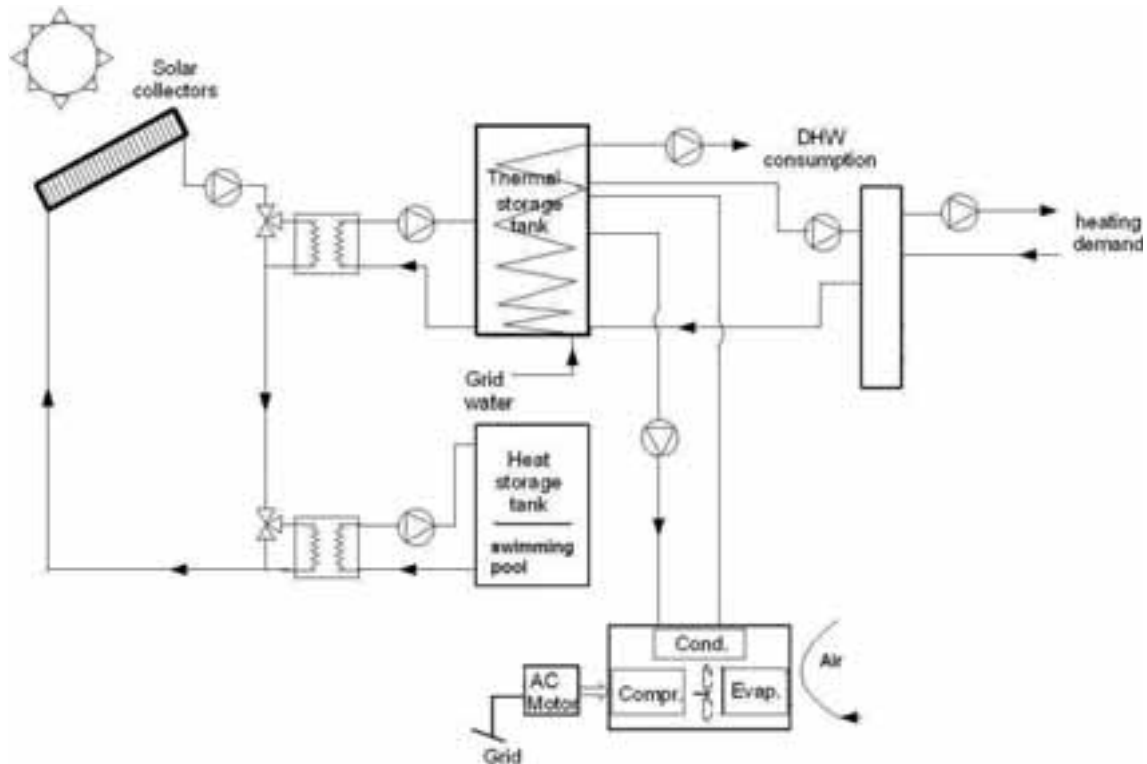

Fig. 1: Schematic diagram of the high efficiency solar thermal contribution system with an air heat pump

In this first configuration the panels are high solar efficiency, and an air-water heat pump, we use between a 500 and 1000 liter storage tank temperature, the solar energy must contribute to the DHW, help to the house heating or pool system production.

Auxiliary heat pump set point temperature must be high (about 50 °C) during winter in order to activate the heating system (heated screed floor or fan coils), but can be reduced (to about 30 °C) in autumn time if the pools are used.

The heat pump is absorbing the heat from the air, these systems are very usual in Mediterranean areas, where the winter it's quite warm (7-10 °C), only they have some days below 0°C.

The surface of the solar panels can go from 6 to 18 square meters, depending of the size of the house and the thermal demand. These systems provide with solar energy more than the 70% of the DHW and 30-50% of calefaction, and the 100 % of the pool necessities.

We can cover up to a 50% of the thermal necessities, with a COP of 3 to 4, consuming only the 16% of the energy from the electricity.

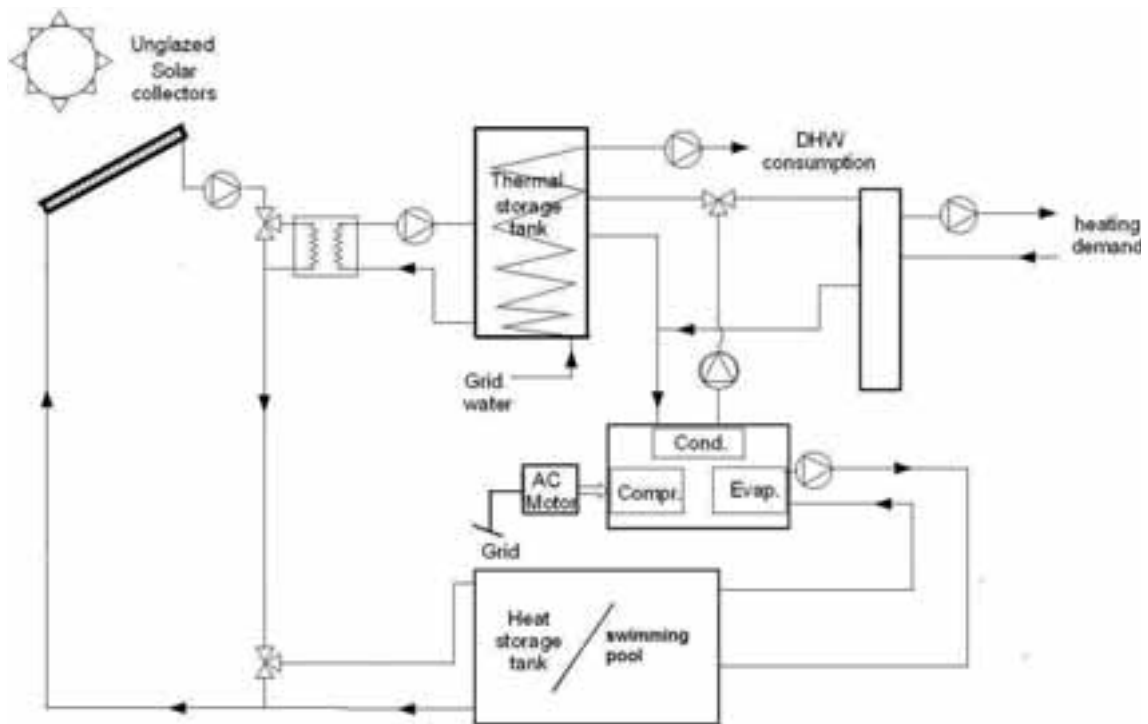

Fig. 2: Schematic diagram of the high efficiency solar thermal contribution system with a water heat pump

In the second configuration, the solar panels are low efficiency, with a water-water heat pump, it's a fully integrated system: the heart of the system is the heat pump but solar energy provides energy to the evaporator side of the heat pump, either through a storage tank or directly, and when possible to the DHW tank and/or to the heating distribution system.

The storage tank is between 300-500 liters. The surface of the unglazed solar panels, because they are low efficiency is tree times bigger than the previous configuration, nevertheless the cost its tree times cheaper. We will require from 25 to 50 square meters, depending on the size of the house and the thermal demand. These systems increase with solar energy the efficiency for DHW and space heating, during some month provides directly the DHW and heating necessities, and the 100 % of the pool demand, with a volume between 50-100 m³.

We can cover up to a 50% of the thermal necessities, with a COP of 4 to 5, consuming only the 16% of the energy from the electricity.

The biggest problem is the low efficiency of the solar panels when they are working with differences of more than 20°C between the water and ambient temperature the efficiency it's falling down. The systems 2 and 3 need less storage volume due to the pool acting as a big buffer.

The advantage of this system it's than the water of the pool can go through the solar panels, saving pumps and heat exchangers, thus simplifying the system. The biggest disadvantage it's that we will need a bigger surface of solar collectors.

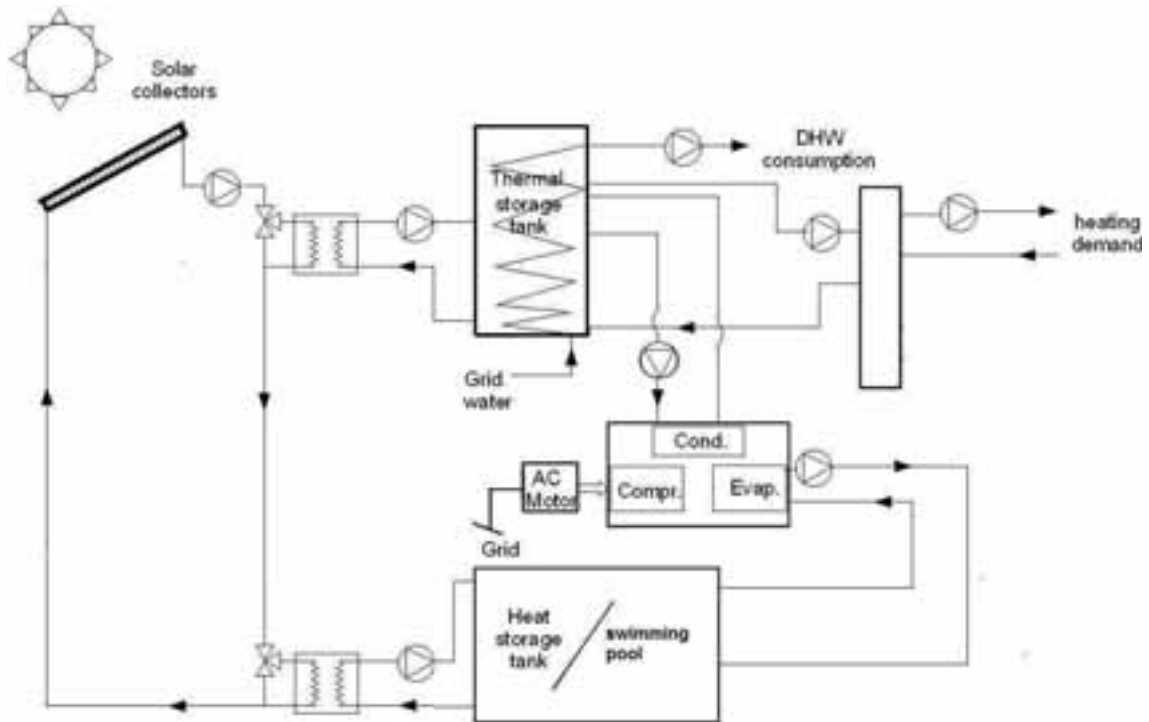

Fig. 3: Schematic diagram of the low efficiency solar thermal contribution system

In the third configuration, we take the same solar panels of the first configuration with a high efficiency, with a water-water heat pump, it's a fully integrated system: the heart of the system is the heat pump but solar energy provides energy to the evaporator side of the heat pump, either through a storage tank or directly, and when possible to the DHW tank and/or to the heating distribution system.

The storage tank is between 300-500 liters. The surface of the solar collector surface will be larger than in the first system to be able to keep warm the pool in winter, it can go from 12 to 24 square meters, depending on the size of the house and the thermal demand. These systems increase the efficiency for DHW and space heating with solar energy. During some month provide directly the DHW and heating, and a 100 % of the pool necessities, with a volume between 50-100 m³.

We can cover up to a 60% of the thermal necessities, with a COP of 4 to 5, consuming only the 11% of the energy from electricity. We are taking the advantages of the two previous systems.

4. Results

Simulating the whole year system we reach different solar contributions, due to the efficiency of the system, the working temperature of the storage system, and the different COP of the heat pump. It has been simulated the minimum temperature of the pool, for the whether conditions at Balearic Island's, we have found out than the water-water heat pump has a higher efficiency than the air-water heat pump. The average temperature never goes down of 11 °C, this validates the second and third system in front of a geothermal heat pump of either close or open loop. There are some short time periods when the pool temperature decreases up to 9°C, when the ambient temperature is -3°C. For cooler areas, we can arrive to freeze the pool; it has been studied than the water/ice latent heat storage tank to the heat pump extraction circuit has a bigger efficiency than the air systems, and the latent heat increase the storage energy capacity [Sonnleitner- Trinkl].

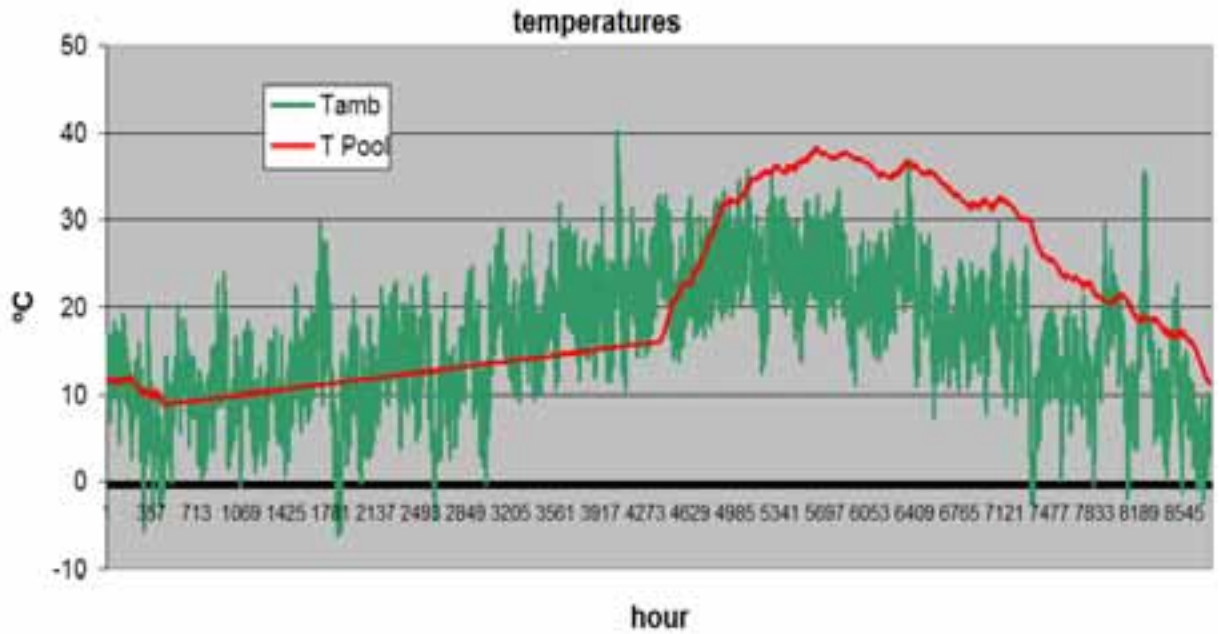

Fig. 4: Temperatures of the pool and air at Balearic Island's.

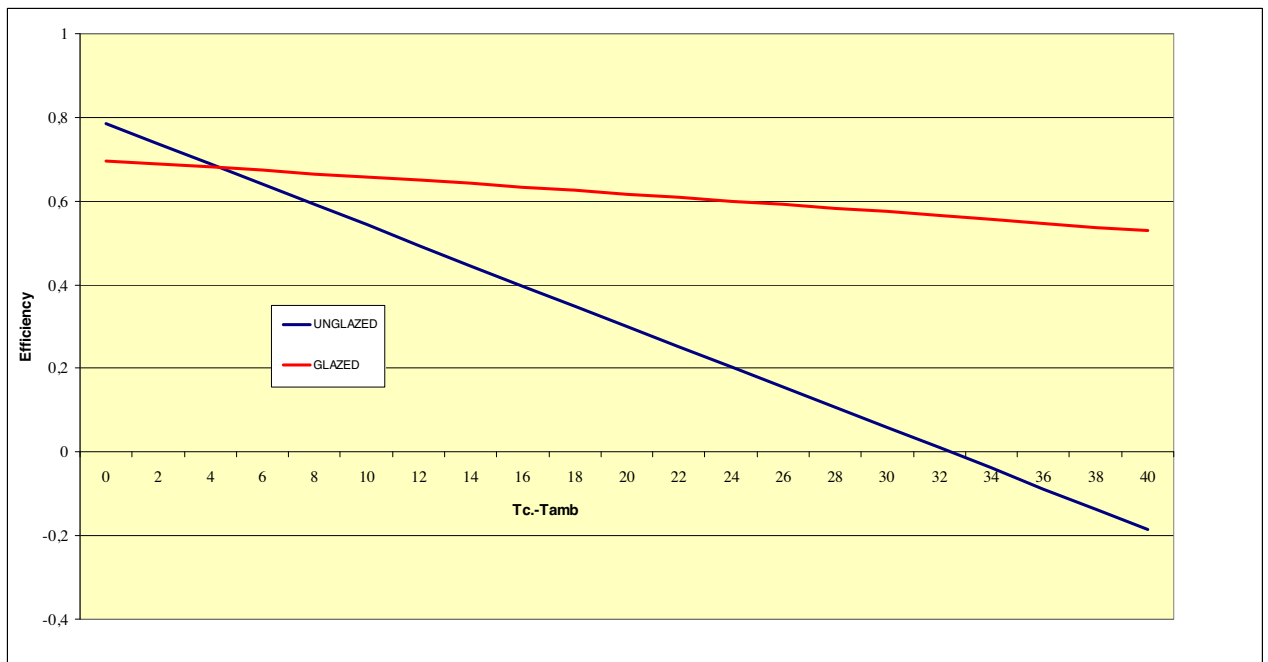

Fig. 5: Efficiency of solar panel with gradient temperature (ambient-averaged solar panel)

For avoiding having a low averaged efficiency, each system tries find out the maximum efficiency for the solar panels to have the maximum solar energy gains, the unglazed panels (low) are working usually with a difference of temperatures of less than 10°C, the pool will be usually in winter at 20°C and in spring and autumn at 25°C, in summer they work close to 50°C, making a direct heat transfer to the DHW, working with a gradient temperature of 25 degrees.

The standard solar panels work with gradient temperatures of more than 25 degrees all the year, because they transfer the energy to the DHW than it's more than 50°C. The result it's that the efficiency it's similar in both systems.

Tab. 1: Table monthly set point and efficiency of the three systems.

Month	System 1. High ef. Solar heat pump (air)		System 2. Low solar ef.heat pump (water)		System 3. High solar ef. heat pump (water)	
	efficiency	ac. Temp.	efficiency	ac. Temp.	efficiency	ac. Temp.
JAN	44%	50	45%	20	55%	30
FEB	45%	50	50%	20	56%	30
MAR	43%	50	43%	25	52%	40
APR	47%	50	37%	30	55%	40
MAY	51%	50	47%	30	58%	40
JUN	54%	50	29%	40	46%	60
JUL	57%	50	11%	50	50%	60
AUG	57%	50	11%	50	49%	60
SEPT	52%	50	27%	40	61%	40
OCT	47%	50	44%	30	56%	40
NOV	49%	50	42%	25	59%	30
DEC	45%	50	53%	20	56%	30
Average	49%	50	37%	32	54%	42

We can see that we can arrive to the same averaged solar fraction with different efficiencies and monthly solar fractions. The system 2 has a low efficiency in summer because it produces DHW with the solar panels without any auxiliary system. The first and the third system have overheating from May to September that potentially could be used for solar cooling applications. The second system reduces the overheating working with higher temperatures, thus reducing its efficiency during summer months to about 11%. The solar heat pump with solar collectors it's a good option with high efficiency compressors, and they can reduce the overheating when combined with absorption systems.

Tab. 2: Table monthly solar fraction of the three systems

Month	System 1 6-18 m ²	System 2 25-50 m ²	System 3 12-24 m ²
JAN	20%	0%*	32%
FEB	20%	0%*	32%
MAR	31%	8%*	49%
APR	38%	42%*	59%
MAY	54%	89%	83%
JUN	100%	100%	100%
JUL	100%	100%	100%
AUG	100%	100%	100%
SEPT	92%	100%	100%
OCT	45%	87%	72%
NOV	33%	19%*	53%
DEC	18%	0%*	30%
Average	54%	54%	68%
Average aux. Energy cons. (MJ)	12.812	13.231	8.846
Aux. Energy cons. MJ/m² year	107	110	74
Aproximated investment Cost (€)	12.325,11 €	8.489,41 €	10.472,48 €

The system 2 had the entire year solar energy fraction, but the cooler months it's not straight, it's indirect through the heat storage tank (pool), to the heat pump extraction circuit, increasing the efficiency.

5. Conclusion

Solar heat pump systems are a good solution for family houses, where we can arrive to high comfort levels with very low energy consumption. There are a lot of systems to be improved for engineers and manufacturers of solar collectors and/or heat pumps. There is a need for the development of 'plug-and-play' or 'ready-to-install' system kit solutions, at least to avoid errors in dimensioning and assembling. To ensure energy efficient operation of such solutions, a control unit which continuously monitors the basic functions of the system including adequate system self-control strategies should be aspired.

The best option from the energy savings it's the third system, but the most economical it's the second one, with unglazed panels.

The unglazed panels combined with a pool or a big storage tank constitute a good system in Mediterranean areas, with similar efficiency to geothermal systems, and a lower cost, and simplifying the hydraulics and control systems.

6. References

Felgner, F., Agustina, S., Cladera Bohigas, R., Merz, R., Litz, L., 2002. Simulation of thermal building behaviour in Modelica. 2nd International Modelica conference, 2002, Oberpfaffenhoffen, Germany.

Jean-Christophe Hadorn, A new IEA SHC Task 44 & HPP Annex And analysis of several combinations for a low energy house. Proceedings of the EuroSun 2010, Graz, Austria.

Elimar Frank, Michel Haller, Sebastian Herkel and Jörn Ruschenburg. Systematic Classification of Combined Solar Thermal and Heat Pump Systems. Proceedings of the EuroSun 2010, Graz, Austria.

Sonnleitner, Matthias, Trinkl, Christoph Zörner, Wilfried. In-situ investigation of a domestic solar/heat pump Heating system in a one-family house. Proceedings of the EuroSun 2010, Graz, Austria