

AMERICAN SOLAR ENERGY SOCIETY



SOLAR
2016

July 10 - 13, 2016
San Francisco, CA

Conference Proceedings

Edited by Dr. Richard Perez and Dr. David Renné



American Solar Energy Society National Solar Conference 2016 Proceedings

Edited by

Dr. Richard Perez
Chair, SOLAR 2016 Technical Review Committee

and

Dr. David Renné
Chair, SOLAR 2016 National Organizing Committee

Copyright © 2016 by the American Solar Energy Society

American Solar Energy Society
2525 Arapahoe Ave, Ste E4-253
Boulder, CO 80302

Email: info@ases.org
Web: <http://www.ases.org>

ISBN: 978-3-9814659-4-5

All rights reserved. No part of the publication may be reproduced, transmitted, in any form or by any means, electronic, mechanical, photocopying, recording or otherwise, without permission of the publisher, except in the case of brief quotations embodied in critical articles and review or where prior rights are preserved.

Produced by

International Solar Energy Society
Wiesentalstr 50
79115 Freiburg
Germany

Tel: + 49 761 45906 – 0
Fax: + 49 761 45906 – 99
Email: hq@ises.org
Web: <http://www.ises.org>

Notice

Neither the International Solar Energy Society and the American Solar Energy Society, nor any one of the supporters or sponsors of the American Solar Energy Society National Solar Conference 2016 (SOLAR2016) makes any warranty, express or implied, or accepts legal liability or responsibility for the accuracy, completeness or usefulness of any information, apparatus, product or process disclosed, or represents that its use would not infringe privately on rights of others. The contents of articles express the opinion of the authors and are not necessarily endorsed by the International Solar Energy Society, American Solar Energy Society or by any of the supporters or sponsors of SOLAR 2016. The International Solar Energy Society and the American Solar Energy Society do not necessarily condone the politics, political affiliation and opinions of the authors or their sponsors.

Table of Contents

Introduction

Introduction

<i>R. Perez</i>	2
-----------------------	---

Solar Buildings and Architecture I and II

A Case Study on the Merits and Design of a Solar Powered Internet of Things: Intelligent Window Shades

<i>D. Drake, J.S. Preston</i>	4
-------------------------------------	---

Design Schools as Drivers for Sustainable & Affordable Housing

<i>C. Hazel, L.D. Iulo</i>	12
----------------------------------	----

Solar Electricity - Economics & Policy I and II

Comparing Carbon Fees with Existing Financial Incentives for Solar Electricity

<i>J. Schaefer</i>	22
--------------------------	----

The Hazards of Exponential Growth for the Solar Industry – and How Innovating Stronger Business Models Is Key to Survival

<i>E.I. Schwartz</i>	28
----------------------------	----

SMUD Solar: A Roadmap for Utilities in Transition

<i>W. Schirtzinger, D.W. Aitken, D.E. Osborn, S.J. Strong</i>	33
---	----

High-Efficiency ZEB & Control Systems

Guidelines for Residential Sub Metering

<i>M. Hatch, H. Rashed-Ali</i>	44
--------------------------------------	----

Inhouse

S. Stannard, R. Beller, L. Mueller, A. Parr, K. Schollenberger 55

Maryland Net Zero Energy Schools Program

D.L. Comis 61

House Energy Doctor’s Level III Building Energy Audits as Pedagogy and Outreach

N.V. Chalfoun 66

Resource Assessment: Models & Data

Solar Energy Assessments: When Is a Typical Meteorological Year Good Enough?

S. Pelland, G. Bender, R. Kenny, L. Leahy, C. Maalouf, B. Schneider 77

Global Validation of REST2 Incorporated Into an Operational DNI and GHI Irradiance Model

W.T. Gustafson, G. Bender, L. Leahy 84

Renewable Energy Grid Integration

Some Consequences to Grid Operation Due to High Penetration of Distributed PV Systems

U. Ponsukcharoen, W. Murray 94

Assessing Demand Impact of Solar Capacity Growth in Philadelphia

J. Ranalli 104

Resource Assessment: Forecasting & Remote Sensing

Forecasting Solar Power and Irradiance – Lessons from Real-World Experiences

S.D. Jascourt, C. Cassidy, D. Kirk-Davidhoff 112

An Assessment of New Satellite Data Products for the Development of a Long-term Global Solar Resource At 10-100 km

*P.W. Stackhouse, S.J. Cox, K. Knapp, J.C. Mikovitz, R. Perez, B. Scarino,
J. Schlemmer, M. Sengupta, T. Zhang* 121

Solar Thermal Technology Advances I

'New Standard' Solar Hydronic Building Systems: State of the Art in New Mexico 2016	
<i>B. Stickney</i>	128
Solar Thermal Collection with Seasonal Storage	
<i>G. Olson, Y. Yu</i>	137

SANE - Forum

The Spartan Superway: A Solar-Powered Automated Transportation Network	
<i>B.J. Furman</i>	147
Case Study of a Solar Power Installation on an Automated Transit Network in San Jose	
<i>L. Branco, B.J. Furman, D. Marques de Queiroz Neto, E. Rosenfeld</i>	157
A Study on the Effects of Urban Shadow Impingement on Solar Powered Transportation Systems	
<i>I. Gendler</i>	167

The Value of Distributed Solar Resources

The Right Tone of VOS: Improving the Argument for Local Community Solar	
<i>J. Cliburn, J. Bourg, J. Powers</i>	178
Influencing Utilities Through Shareholder Advocacy: the Madison Gas & Electric Case Study	
<i>D. Wichert, B. Esser</i>	188
Net Metering PV Distributed Resources Benefits All Stakeholders on PJM	
<i>P.M. Jansson</i>	194

Poster Presentations

Design of Wearable Agricultural Solar-powered Sprayer for Remote Areas	
<i>A.M. Farrag</i>	202
Challenges for the Expansion of Solar Power in Brazil	
<i>D.G. Giacobbo</i>	212

Solar Power for Rural America	
<i>J. Glenn</i>	219
Collaborative Prototype Development & Test Project for a Novel Hybrid Solar Concentrating Cogeneration System	
<i>M. Sankrithi, S. Watkins</i>	223

Introduction

Introduction

*Proceedings, Solar 2016 National Solar Conference
San Francisco, CA
July 11-13, 2016*

Dear Reader,

As the Chairs of the Technical Review Committee and the National Organizing Committee we are very pleased to present you with the Proceedings of the Solar 2016 National Solar Conference, organized by the American Solar Energy Society. This Conference was held in conjunction with Intersolar North America at the Intercontinental Hotel on July 11-13, 2016. This Proceedings consists of full papers submitted voluntarily by authors who had accepted abstracts for either oral or poster presentations. The papers are organized according to the technical session in which they were presented during the Conference. Each paper has been assigned a DOI number so that it is easily referenceable by the research community. This year Proceedings are made available online by PSE GmbH, located in Freiburg, Germany, working under the guidance of the International Solar Energy Society.

The theme of Solar 2016 was “Progress in Solar Energy”, and the collection of papers assembled in this proceedings offers excellent examples of work being done with solar technologies, architectural practices, grid integration and operations, and community programs that support the transformation of our energy system to a 100% renewable energy world. We invite you to visit the ASES website (www.ases.org) and the ISES website (www.ises.org) to learn more about the work being undertaken by these organizations to support the transformation, and to join both of these organizations if you are not yet a member.

We would like to thank ASES organizing the National Solar Conferences, and also thank all of the participants in Solar 2016 for their contributions. We want especially want to acknowledge ISES and PSE GmbH for making the Proceedings broadly available to the solar energy community.

Sincerely,

Dr. Richard Perez, Chair, Solar 2016 Technical Review Committee
Dr. David Renné, Chair, Solar 2016 National Organizing Committee

Solar Buildings and Architecture I and II



A Case Study on the Merits and Design of a Solar Powered Internet of Things: Intelligent Window Shades

David Drake¹, John Stewart Preston¹

¹ McMaster University, Hamilton (Canada)

Abstract

The Internet of Things (IoT) is the concept of integrating smart electronics into ordinary objects so that all these devices can work together to provide advanced services to their user. Estimates of the value of this market are in the trillions and are recognized by market surveys and company estimates. Conventional wired power is not appropriate for all IoT devices. Of available energy harvesting techniques, solar is one of the most mature, robust and energy dense solutions. A case study of the design of a solar powered window shade is reviewed. Methods to ensure the prototype can: cheaply optimize power generation, operate robustly and function with energy neutrality are reviewed. These design techniques could be applied to other solar powered IoT devices.

Keywords: *Internet of Things, Energy Harvesting, Solar, Design, Prototype, Energy Neutrality*

1. Internet of Things

The internet of things (IoT) is an exciting, developing field. Objects with integrated communication electronics, sensors and actuators can work together to provide coordinated, intelligent, services. Collecting data from industrial assets for use in a predictive maintenance schedule has been shown to save up to 12% on scheduled repairs and up to 30% on overall maintenance costs while avoiding up to 70% of breakdowns (GE, 2015). Using smart tags on patients and advanced analytics to optimize patient flow, a leading Florida based hospital was able to reduce wait times by 68% (GE, 2015). Smart, networked devices have been shown to reduce waste and provide useful services in many different contexts.

Various market specialists have developed methods to quantify the value of the IoT. General Electric (GE) (2015) reports that the value of industrial IoT, neglecting consumer or retail, to be \$500 billion by 2020, increasing to \$15 trillion by 2030. Cisco reports that between 2013 and 2022 the entire value of IoT will be \$14.4 trillion (Bradley et al., 2013). By analyzing the house sales of automated and conventional homes, Petersen et al. (2001) found that home buyers are willing to pay a 27% premium for homes with automated systems. Not only is IoT useful, it also a technology with current market value and should be developed further.

2. Benefits of Solar Energy Harvesting

Devices that require portability, remote deployment or cheap installation, may not be adequately serviced by conventional wired power. Rabaey et al. (2000) discussed the implications of installing individual wiring for sensors, estimating the cost at \$200 per sensor. Portable batteries are commonly used to solve this problem, but batteries have a finite capacity and there is a maintenance cost associated with replacing or recharging dead batteries. Harvesting energy from a local source offers a potential solution to this problem.

A simple IoT device gathers and relays information about its location. Such a device requires a microcontroller, transceiver, sensor and power supply. These designs typically require between 15-1500 μ W

while in sleep mode and 5,000-80,000 μW while active (Beeby and White, 2010). More complicated IoT devices, such as a motorized window shade, would include an actuator to allow the system to respond to external conditions, further increasing power requirements. Modifying the duty cycle so the node is put to sleep more frequently will reduce its average power demand.

A variety of different energy sources and their potential electrical energy densities are presented in Table 1. While each of solar, piezoelectric and thermoelectric technologies are able to supply a similar level of power to an IoT device's sleep power, there are several advantages to solar. The unattenuated natural sunlight provides around 100 mW/cm^2 of radiant flux which a solar cell can convert into roughly 15 mW/cm^2 of electricity. Experimental work has indicated that a double pane window with a LOE180 coating from Cardinal Glass industries will transmit up to 70% of useful light. An alternative product, a triple pane window with a heavier LOE272 coating, was found to only transmit 30% of useful light. Even considering this light attenuation, a solar cell with direct line of sight of the sun could generate orders of magnitude more power than alternatives. An indoor solar cell can only generate around $15 \mu\text{W/cm}^2$; an amount on par with thermal and piezoelectric alternatives. Even though power may be limited by dim indoor lighting, application mobility is not. Light spreads throughout a well-lit room allowing an energy harvester to be placed in many locations. Further, the maturity of solar technology makes the technology affordable and easy to source.

Tab. 1: Sources of ambient energy

Energy Source	Converted Electrical Power Density	Information Source
Solar Cell (outdoor average)	$15,000 \mu\text{W/cm}^2$	AM 1.5 Spectrum
Solar cell (inside through double pane LOE180 window)	$10,500 \mu\text{W/cm}^2$	Experimental
Solar cell (inside through triple pane window with two coatings of LOE272)	$4,500 \mu\text{W/cm}^2$	Experimental
Solar cell converting indoor light	$15 \mu\text{W/cm}^2$	Paradiso and Starner 2005
5°C temperature gradient using thermoelectric generator	$60 \mu\text{W/cm}^2$	Paradiso and Starner 2005
Vibrating Microwave with Piezoelectric	$60 \mu\text{W/cm}^3$	Roundy 2003
75 dB Acoustic Noise with Piezoelectric	$0.003 \mu\text{W/cm}^3$	Roundy 2003

3. Motorized Window Blind Case Study

As an IoT device, motorized window shades provide several benefits to their users. O'Brian et al. (2013) conducted a comprehensive review of studies exploring occupant use of window shades over the past 35 years. Multiple studies have concluded that when window dressings are easier to operate, building inhabitants will use them more frequently implying that the user receives improved utility from the device. One study noted an increase in use by a factor of three by introducing automated controls. Occupants are not likely to use their window dressings to optimize energy performance of the building. They don't modify the position of window dressings in anticipation of future thermal conditions; instead they change blind position for immediate needs such as reduction of glare or improved privacy. This problem is exacerbated in public areas like hallways, waiting areas, or shared offices because people do not want to disturb other occupants or will not be in that space long enough to be bothered by the thermal conditions. Automated IoT solutions could predictively manage shades to optimize a building's passive thermal performance while also offering inhabitants a more convenient method of operating nearby window blinds.

The large power density of photovoltaic cells using window attenuated solar irradiance is quite high. Since window blinds are naturally placed directly behind a glazing, it makes sense to use solar energy to power this device. The remainder of this section examines the unique design features and analysis used to integrate solar power into a motorized blind prototype.

3.1. Prototype

The completed motorized blind prototype is shown in Fig. 1 (a) with images of the various subsystems shown in Fig. 1 (b)-(f). It was constructed by adding custom electronics and actuators to a conventional roller shade. This type of window dressing requires a bottom rail to keep the suspended fabric flat. The prototype's bottom rail was redesigned to integrate a solar array. A full electrical system was designed to ensure wireless uninterrupted operation. Nickel Metal Hydride (NiMH) batteries were selected to receive a trickle charge from the solar array and provide power to the device when light is not available. A microcontroller tracks operation and control's when the motor moves the blinds. A wireless chip connects the prototype to the user's local Wi-Fi network to communicate directly with a server without the need of any intermediary device. The majority of control electronics are hidden with the top cylinder of the blind to hide the operating circuitry from the sight of the user.

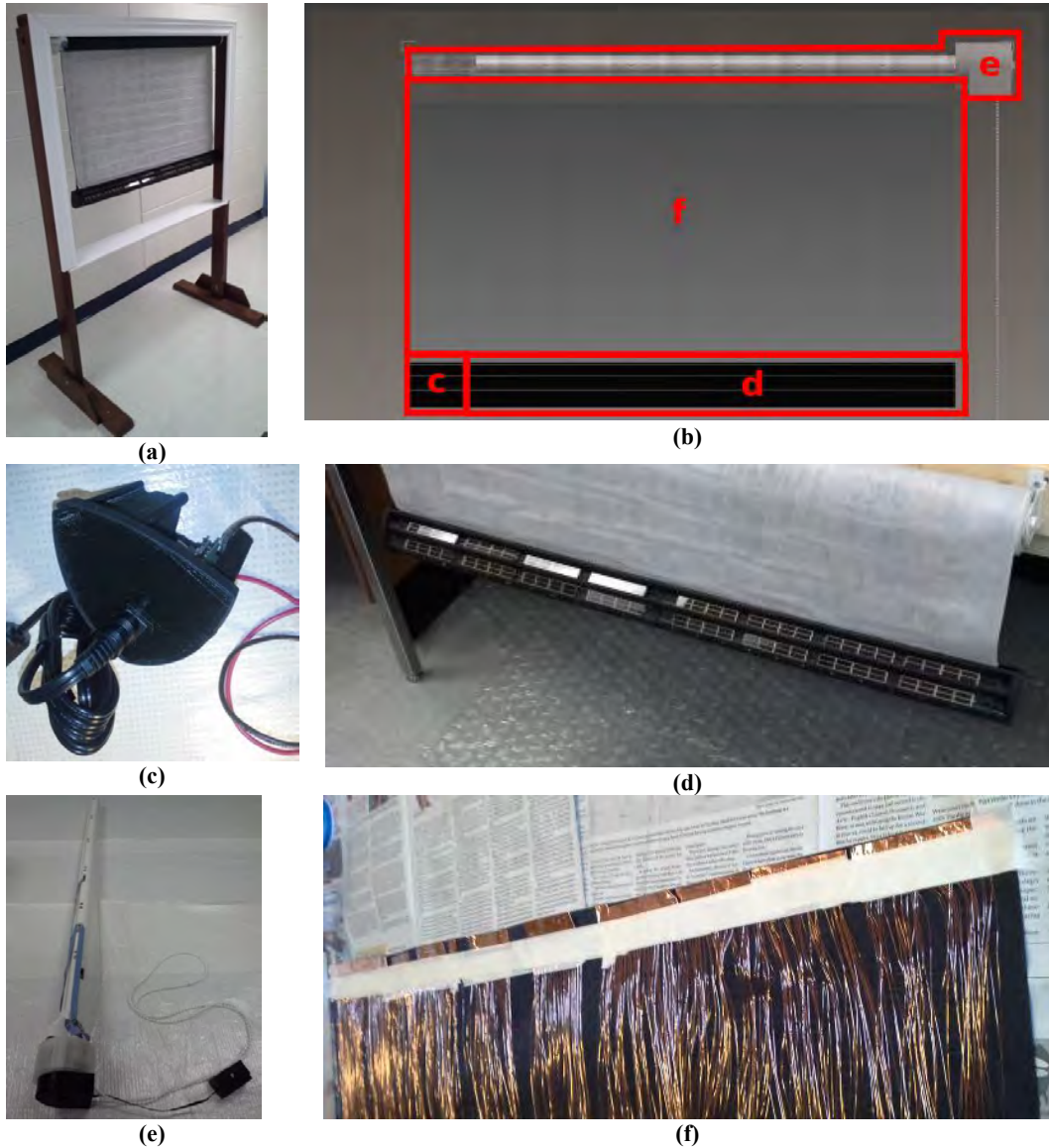

Fig. 1: Images of the prototype assembly. (a) is the entire assembled prototype. (b) illustrates the various subsystems that are shown in images (c)-(f). (c) is a backup recharging mechanism while the primary solar harvesting array is shown in (d). The electronics that operate the window blind are shown in (e). The solar array and control electronics are connected through conductive fabric shown in (f).

3.2. Economical Power Optimization

Many methods are known to improve the ability of solar panels to generate electricity. Many variables must be considered while implementing these techniques such as increased component cost, or extended development time. Some well-known techniques were simplified to optimize electrical generation in the solar powered blind prototype.

The more direct light a solar cell receives, the greater the output power. Tracking solar farms use this to their advantage by employing automated systems that physically manoeuvre panels to maximize direct sunlight. A lower cost technique is to mount solar panels at a static angle that maximizes their yearly generation potential. North American solar farms that employ this technique typically orient their panels due south at an angle equal to the location's latitude. Studies have shown that the maximum energy generated is insensitive to panel tilt within $\pm 10^\circ$ of the optimal tilt angle (Rowlands et al., 2011) (Qui and Riffat, 2003). To ensure this prototype has versatile generation capability, the bottom rail was designed with grooves capable of holding two rows of solar panels tilted at angles 25° and 45° from the horizontal as shown in Fig. 2 (a). One of the two rows will be mounted at near its optimal static angle for the large population of potential users who live in latitudes of 15°N to 55°N . There are additional advantages to this configuration such as a smoother overall power generation profile. For example, in a southern location, the shallow tilt should produce more power overall, but at certain times, like sunrise or sunset, the sun may be low in the sky allowing the steeper tilted array to pick up the slack.

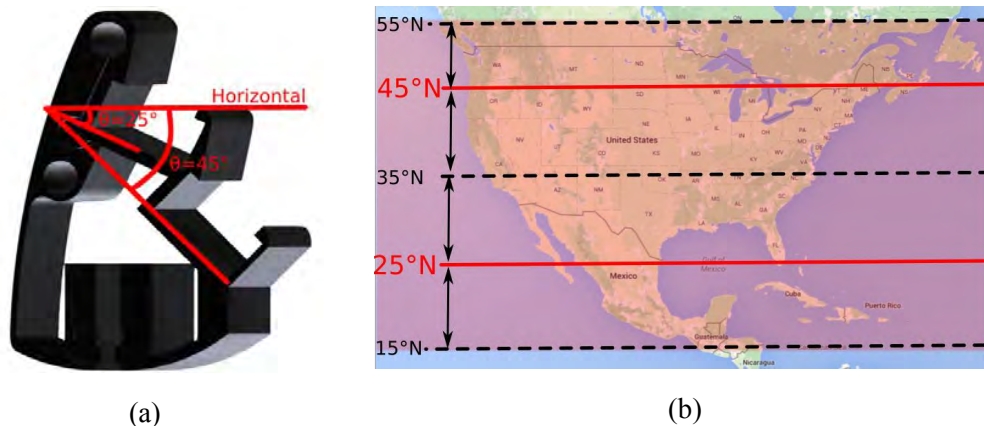

Fig. 2: Cheap methods of optimizing power. (a) shows the angled grooves where solar arrays are installed at the bottom rail. These angles were designed to optimize incident light collection at a variety of latitudes. (b) shows the latitudes where these angles are optimized (red lines) and the region where one of the arrays collects near optimal solar energy (red overlay).

The available power from a solar array is a function of the terminal voltage and can vary from its maximum to a level near zero. Maximum power point trackers (MPPT) are commonly employed in large scale commercial generation facilities to ensure that solar modules operate near their theoretical maximum. While a custom MPPT could be designed for IoT applications it would require development time and the extra cost of parts.

The prototype's battery pack was connected directly to the solar array. The battery voltage dictates the operating point of the solar array. The NiMH battery pack is made of 12 series cells and operates between a range of 10.9 V and 17.5 V based on the remaining charge. The solar array is 32 series cells with a peak power point located at about 16 V when illuminated with 1 sun. The battery forces the solar cells to operate at a level near their maximum power point as shown in Fig. 3. This simple connection expedited the development of a working prototype that operates near the maximum power point. The benefits of integrating a custom MPPT can be revisited in future design iterations.

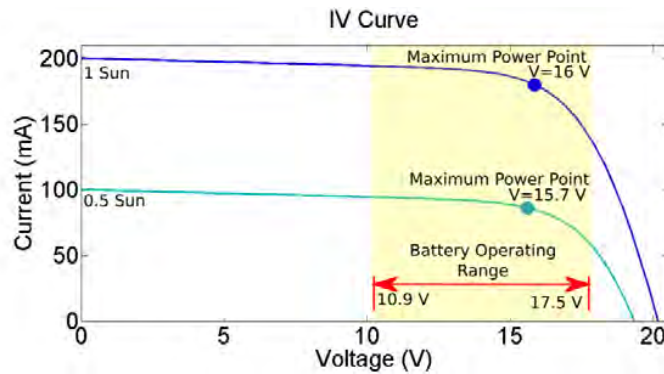

Fig. 3: The IV curve of the solar cell with the operating range of the battery overlaid in yellow. The battery pack enforces a near optimal terminal voltage on the solar array.

3.3. Robust Operation

Consideration must be given to the variability of the environments this device could be deployed in. Care was taken to ensure the design would operate where impinging sunlight was unreliable.

Window grilles or external obstructions such as a leafy tree could cause spotty covering of direct sunlight. When shaded, series-connected solar cells become loads that limit the ability of the series stack to generate current. One solution is to wire cells in parallel. A shaded cell would not contribute current, but would not inhibit other cells from contributing current either. This solution was applied to the extent feasible. Four stacks of 32 series solar cells were placed in parallel. The 32 series cells were necessary to match the battery pack's operating voltage. To further improve performance, Schottky bypass diodes were placed across every 8 cells. If significant shading occurred across 8 cells, current from the remainder of the stack could flow through the diode with reduced system losses.

It is possible that the solar array could end up entirely shaded, forcing the system to operate off battery power until the battery is depleted of charge. A secondary recharging mechanism was designed to allow users to recharge the system in a convenient and accessible way. Fig. 1 (c) shows a wall adapter power supply plugged into the bottom rail to provide power to recharge the system. This mechanism doesn't require the user to open up their device. By locating the connection in the bottom rail, users can access the connector with minimal effort.

3.4. Energy Neutral System

In order to keep the solar powered blind running continuously the system must operate with energy neutrality. This means that the total energy harvested must equal the energy used. This concept contrasts the business models of solar farms that sell electricity immediately as it is generated. Energy neutrality was ensured by including battery storage to power the load in the absence of light.

With any self-powered system, it is necessary to develop an understanding of what ambient energy is required for the system to stay reliably powered. This section reviews several techniques used to analyse the required irradiance to balance the solar powered blind prototype. These techniques assume a sinusoidal irradiance profile as shown in Fig. 4. Given various day lengths, the input irradiance varies from 0 mW/cm² to a maximum value, Φ_{max} . The following analysis techniques estimate what value of Φ_{max} would allow the system to operate continuously.

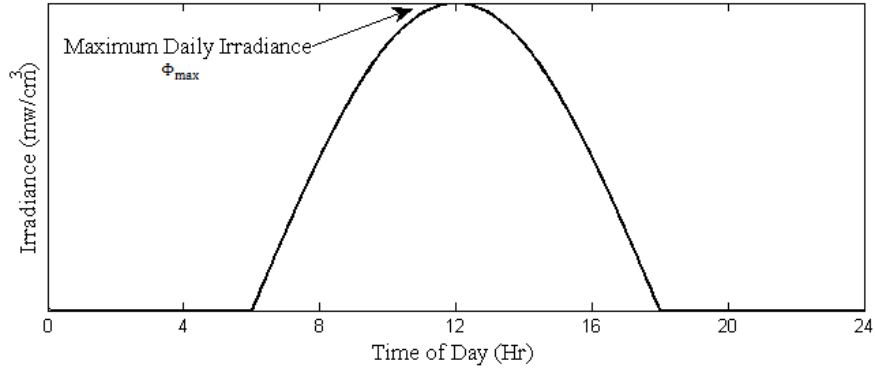

Fig. 4: Assumed daily irradiance profile used for energy balance. This particular profile considers a 12 hour day, however, other day lengths have been considered.

3.4.1 Analytical Energy Balance

An analytic expression for minimum necessary irradiance can be developed using several simplifications. Consider an almost empty battery operating with a voltage of 10.9 V. This voltage is far lower than the typical peak power point of the solar array so the entire array is modelled by a simple current source that operates at its short circuit current point (I_{array}). This value varies from the datasheet value (I_{sc}) which is taken when the cell is illuminated by a standard flux (Φ_{std}) of 100 mW/cm². Equation 1 shows how the radiant flux density (Φ), measured in mW/cm², can be used to calculate I_{array} .

$$I_{array} = I_{sc} \frac{\Phi}{\Phi_{std}} \quad (\text{eq. 1})$$

If the solar cell is modelled as a current source that is linearly dependent with irradiance, the total amp hours that the solar cell produces in a day, Q_{Ahr} , can be evaluated with the integral shown in equation 2. This is a flexible form that considers a variable number of daylight hours, n_{hr} , with the time-dependant sinusoidal irradiance profile.

$$Q_{Ahr} = \int_0^{n_{hr}} \frac{I_{sc} \cdot \Phi_{max}}{\Phi_{std}} \sin\left(\frac{t-\pi}{n_{hr}}\right) dt = \frac{2 \cdot n_{hr} \cdot I_{sc} \cdot \Phi_{max}}{\Phi_{std} \cdot \pi} \quad (\text{eq. 2})$$

At the depleted voltage of 10.9V, the prototype requires an average of 8.74 mA to operate, or 210 mAhr over a day. By equating this to Q_{Ahr} and substituting the datasheet's short circuit current of 200 mA, an assumed day length of 12 hours, and the reference irradiance of 100 mW/cm², Φ_{max} can be isolated and solved. This is done in equation 3. This method estimates 13.7 mW/cm² is necessary to keep the prototype continuously powered.

$$\Phi_{max} = \frac{Q_{Ahr} \cdot \Phi_{std} \cdot \pi}{2 \cdot n_{hr} \cdot I_{sc}} = \frac{210 \cdot 100 \pi}{4800} = 13.7 \text{ mW/cm}^2 \quad (\text{eq. 3})$$

3.4.2 Numerical Energy Balance

A more accurate estimate can be obtained by considering the many system nonlinearities. A model is currently being developed that considers the complete IV curve of the solar array, the voltage dependant power draw of the prototype's control circuit and the nonlinearities of the electrochemical battery. This model simulates the system by iterating through small time increments. At each time increment, the system's operating conditions are recalculated given changing battery voltage, load patterns and the time-varying irradiance profile. Several simulations were run to determine Φ_{max} necessary to ensure the battery lost no charge over the course of 24 hours. The simulation considered various day lengths and batteries initialized with different amounts of stored charge. The results are shown in Fig. 5.

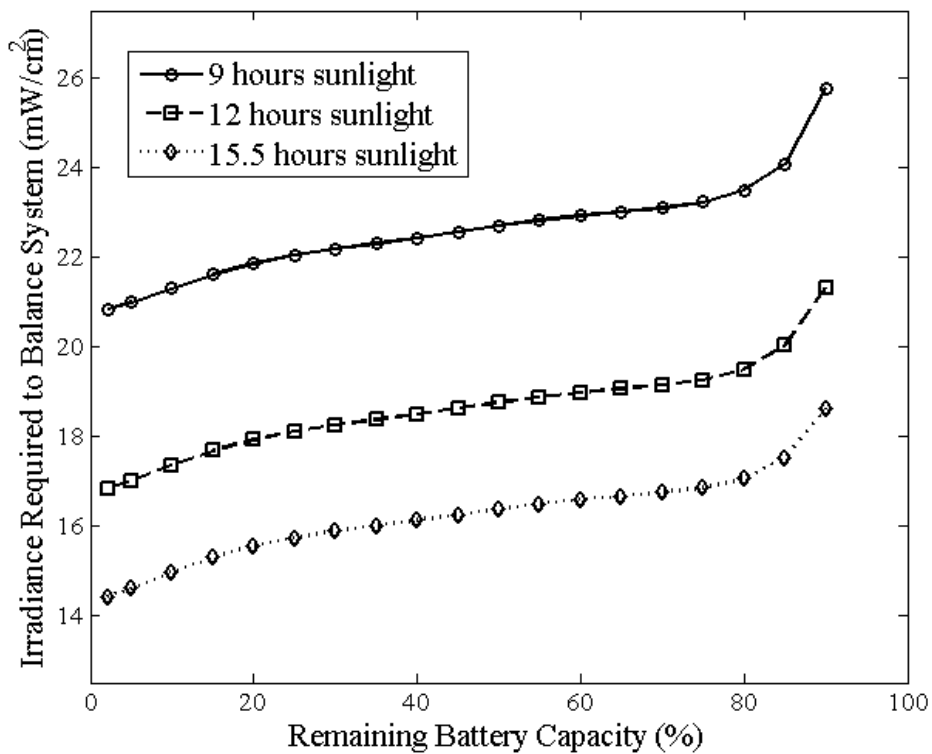

Fig. 5: Estimated input irradiance necessary to maintain the prototype's modeled battery charge given different initial stored charge. The simulation day lengths of 9, 12 and 15.5 hours are chosen to correspond with the with the day lengths in Hamilton, Ontario during the winter solstice, spring equinox and summer solstice, respectively.

As the amount of charge stored in a battery increases, its terminal voltage increases. More sunlight is required by the solar cell to produce enough current to keep the system balanced. As the day length increases more sunlight is collected overall, and the peak irradiance requirement is lowered.

3.4.3 Solar Blind Energy Balance Feasibility

The simplifications in the analytical model provide a ballpark estimate that undershoot the estimate when nonlinearities are considered. The numerical model predicts that a peak irradiance of 16.8 mW/cm^2 is required to balance this system for a 12 hour day while the analytical requires 13.7 mW/cm^2 . Both analytical and numerical methods estimate the required Φ_{\max} to be less than 30 mW/cm^2 . As discussed in Section 2, experimental work indicates that a highly tinted window will attenuate direct sunlight by 30%, providing a peak irradiance of 30 mW/cm^2 . These models imply that the prototype would be able to perpetually power themselves if they are placed behind a window with no further obstructions.

4. Conclusion

There is huge market potential for IoT products. Conventional wired power systems aren't appropriate for all products. Solar panels are a mature technology that uses a predictable and abundant light to provide electricity and can be a good alternative to wired systems. A case study of the design and operation of a motorized blind system was reviewed to discuss what design features were implemented to make the system operate continuously. Lessons from this case study can be applied to other solar powered IoT devices such as:

- Determine a static mounting angle that works for a large region of potential users.

- Design battery pack and solar array for direct connection to reduce development time.
- Ensure continuous power generation during intermittent shading by wiring solar cells in parallel or implementing bypass diodes in series stacks.
- Plan for outages and irregular use by including an alternative charging method.
- Perform an analytical energy balance to determine what situations are reasonable to use the system.

5. References

- S. Beeby and N. White. 2010. Energy harvesting for autonomous systems. Artech House, Norwood, MA.
- J. Bradley, J. Barbler and D. Handler. 2013. Embracing the internet of everything to capture your share of \$14.4 trillion. Cisco white paper.
- GE. 2015. Industrial internet insights report. GE white paper.
- W. O'Brien, K. Kapis and A. Athienitis. 2013. Manually-operated window shade patterns in office buildings: A critical review. *Building and Environment*, 60, 319-338.
- J. Paradiso and T. Starner. 2005. Energy scavenging for mobile and wireless electronics. *Pervasive Computing*, 4, 18-27.
- T. Petersen, P. Williams and A. Mills. 2001. Analysis of the value of home automation systems. *Facilities*, 19(13/14), 522-530.
- G. Qiu and S Riffat. 2003. Optimum tilt angle of solar collectors and its impact on performance. *International Journal of Ambient Energy* 24(1), 13-20.
- J. Rabaey, M. Ammer, J. da Silva Jr, D. Patel and S. Roundy. 2000. Wireless Networking. *IEEE Computer* 33(7), 42-48.
- S. Roundy. 2003. Energy scavenging for wireless sensor nodes with a focus on vibration to electricity conversion. PhD dissertation.
- I. Rowlands, B. Kemery and I. Beausoleil-Morrison. 2011. Optimum solar-PV tilt angle and azimuth: An Ontario (Canada) case-study. *Energy Policy* 39, 1397-1409.



ASES National Solar Conference 2016

Design Schools as Drivers for Sustainable & Affordable Housing

Christopher Hazel, Lisa D. Iulo

The Pennsylvania State University, State College (USA)

Abstract

As prices and technical qualities of houses rise, the availability of both high performing and affordable housings seems to drop. Therefore, there is a need to raise the overall standard of general homebuilding to meet the needs of the contemporary resident—ecologically, socially, and financially. Additionally, there is a need to educate future designers about these arising complexities in the AEC (architecture, engineering, and construction) field that they will need to handle as they pass through school and into the profession. Over the past two years, a group of students from The Pennsylvania State University have been tackling both of these issues simultaneously by acting as the designers of an ecologically and financially conscious house within their own community. The students, with Energy Efficient Housing Research Group (EEHR) at Penn State, entered the Department of Energy's Race to Zero design competition. Instead of using a hypothetical situation, the team embraced a site in State College owned by the State College Community Land Trust (SCCLT, a non-profit organization that buys and sells houses to income-qualified buyers). After over a year of research and development, the design of the duplex is in the final stages. The result is a better and more engaged education for the students, a greater foundation of research for EEHR and Penn State, and new homes for the community of State College.

Keywords: *Education, Land Trust, Sustainability, Affordability, Community Design.*

1. Introduction

In order to appropriately and effectively combat some of the architectural and housing concerns that have arisen over the past several decades, namely affordability and energy efficiency, we must find ways of engaging students in design school so that they focus on these problems early in their careers and fully understand the complexities that go into these architectural systems. As prices and technical qualities of houses increase, the availability of both high performing and affordable housing seems to drop. Therefore, there is a need to raise the overall standard of general homebuilding to meet the needs of the contemporary resident—ecologically, socially, and financially. Additionally, there is a need to educate future designers about these arising complexities in the design field that they will need to handle as they pass through school and into the profession. Over the past two years, a group of students from the Pennsylvania State University have been tackling both of these issues simultaneously by acting as the designers of an ecologically and financially conscious house within their own community.

2. Process

In late 2013, the Energy Efficient Housing Research Group (EEHR is a multidisciplinary Penn State organization housed within the Hamer Center for Community Design with the objective of reflecting upon past housing projects undertaken by the university—such as the 2007 Solar Decathlon entry, the

MorningStar home—while also researching new ways to design, construct, and monitor energy-efficient and affordable homes) was approached by the State College Community Land Trust (SCCLT) to learn about ways to improve energy efficient retrofits to houses that they buy and sell in the community. The SCCLT, one of over 200 land trust organizations in the United States, has been operating within the State College area for over twenty years. The nonprofit organization acquires homes and land in the Borough, an area with a dearth of affordable, non-student housing options, in the interest of providing owner-occupied housing to qualified buyers based on federal income guidelines. Only the house is sold; the land is leased to the homeowner in a long-term lease to ensure that the property remains in the affordable housing market in perpetuity. This arrangement allows for the buyer to apply for a mortgage based only on the cost of the house, thereby reducing home costs by more than 30 percent, and it allows for the home to be sold either to another income qualified buyer or back to the land trust according to a resale formula. The SCCLT also assists in educating and counseling homebuyers to promote the health and well-being of the neighborhood (SCCLT.org). This type of organization becomes especially important in a university town like State College where, over the past several decades, housing has changed drastically from owner-occupied to rental properties.

Soon after the first meeting with EEHR, the SCCLT was presented with the opportunity to buy one of the few undeveloped parcels of land in the State College Borough. This property along University Drive, a major thoroughway that connects to Penn State, allowed for the perfect opportunity to build a new house to showcase the success of the SCCLT, be a beacon of energy-efficient design, and provide new homes for people in need. The R-2 parcel measured at just over 20,000 square feet meaning that the lot was large enough for the construction of a duplex—two connected dwelling units. The SCCLT initially saw an opportunity to parallel a duplex design completed by the Union County Housing Authority in Lewisburg, PA, (under 60 miles East of State College) that was also documented and studied by EEHR. Although the Union County Housing Authority Duplex was similar to the SCCLT project desires in terms of size, energy goals, and affordability—and the house was documented by EEHR to serve as a model for similar housing builders and providers—an alternate approach was sought to design something more site specific. Due to the proximity to campus and an increased focus on Penn State's outreach and engaged scholarship programs, it was decided to use this project as an opportunity to get students involved in local design and have students begin thinking about the complex systems associated with housing and understanding all aspects of sustainable design—environmentally, socially, and economically.

Professor Lisa Iulo, the co-founder and faculty head of EEHR, facilitated the use of this project as the subject for a fourth-year comprehensive design architecture studio during the Fall 2014 semester, a special topics course focusing on the design of a Zero-Energy Ready Homes during the Spring 2015 semester, and the school's submission for the 2014/15 Department of Energy's Race to Zero student design competition. The architecture studio course during Fall 2014 laid the groundwork for the project by providing preliminary research on the need for affordable housing in the State College Borough; more in-depth analysis of the site conditions, the surrounding architectural conditions, and the climatic conditions; and several potential program and design alternatives. This initial work by the studio informed the work of the Spring 2015 special topics course taught by Professors Iulo and Scott Wing. This second course, made up of both undergraduate and graduate architecture and engineering students, focused on fully developing one duplex design that would be aligned with both the U.S. Department of Energy (DOE) Race to Zero competition and the SCCLT's "GreenBuild" initiative.

The DOE Race to Zero competition (formerly Challenge Home) is a paper-based collegiate design competition that, similar to the Solar Decathlon, invites students to design energy-efficient housing but with an aim of making that housing affordable to typical low- and moderate-income homebuyers and without the added challenge of physically constructing and transporting the home. The competition began in Fall of 2013, and Penn State has competed each year since. The second year of the competition left some programming requirements open to each team to determine, availing the Penn State team ("Heritage Homes") to use the property along University Drive as their site so that they could compete with the symbiotic benefit of the land trust organization.

The Race to Zero competition acts simultaneously as an architecture design competition, a construction/development competition, and a building science competition. In addition to designing a

construct-able and aesthetic house, students must develop a solid foundation of research to prove that their house is responsive to their selected site, climate, and demographic. This matched perfectly with a project like the SCCLT duplex where the final design was intended for construction; such a project leaves little room for experimentation and less room for error. During the first week of the Spring 2015 course, the students divided themselves into research groups so that, similar to a working firm, individual students (or groups of students) would be responsible for knowing everything pertaining to their research group and integrating it into the project. The competition judged the design on envelope durability, indoor air quality, space conditioning, energy analysis, financial analysis, domestic hot water, lighting, & appliances, and design goals. The team divided these categories into five research groups: Sustainable Site Design, Building Science/Envelope Design & Durability, Design for Comfortable and Healthy Living, Design for Energy Efficient and Net-Zero Energy Living, and Financial Analysis and Marketing (Fig. 1).



Fig. 1: Research Groups

From the outset of the project, the team distinguished the "Triad of Interests" where they documented what the student team (acting as the designers), the Race to Zero organization (acting as the owner), and the SCCLT (acting as the client) each intended for the project (Fig. 2). This organizational structure helped the team to understand the desired outcomes from each party, and to see the design as more than a hypothetical project, but as homes that people would eventually inhabit. Decisions were no longer coming from a single student nor a single group of students, but instead through communication and collaboration with the SCCLT. This improved the team's understanding of what the SCCLT was looking to get out of the duplex and the needs of the anticipated future homeowners.



Fig. 2: Triad of Interests to organize the desired outcomes of the project by each of the associated parties. Image Source: Penn State 2014-2015 "Heritage Homes" Race to Zero competition team.

The student team worked on basis of a tenet of Integrative Design, "Engage Everybody Early on Everything" (7group and Reed, 2009) to engage all stakeholders of the project throughout the entire design process.

Between January and March of 2015, there was a weekly meeting between students of the competition team, faculty advisors, members of the SCCLT, and industry mentors in order to discuss and collaborate on the project's goals and process. These weekly meetings provided a consistent schedule for the students and a structure for when tasks needed to be completed. The students worked closely with over a dozen industry mentors who were able to give advice and guidance to the project ranging from research, construction or practice experience, to financial/sales experience. These mentors served as a link between the typical hypothetical studio project and the real-world project. Other than simply turning to the internet and following false or misunderstood information, the students were able to reach out to real builders and consultants for information that would inform the design.

3. Project

The PSU team name for the Race to Zero competition was H4 - Heritage Homes: High-Performance Living in Harmony with Community, and they started their competition book with the statement, "Good architecture learns from the past, responds to the present, and inspires the future" (Penn State, 2015). As mentioned before, the goal was not simply design a duplex, nor even a high-performing one, but one that would connect with the State College community and the existing built environment. During the contextual and historical study done by the Fall 2014 studio class and the competition team, the image of the bank barn and the farmhouse consistently emerged. Both of these building typologies are very important to Pennsylvania architecture, and they are certainly still relevant to an area like State College that both contains a university founded on agriculture and farming and is still surrounded by agriculture and farms that date back centuries.

Adjacent to this contextual study and analysis, the competition team also held community design charrettes to garner interest and feedback on the project. During these large design meetings, the students would interact and collaborate with members of the SCCLT, local homeowners, faculty and staff outside of the project, and industry partners. This, different than traditional architecture studios, allowed students to see their work through the eyes of people who are not architects and not studying to be architects; it allowed students to really engage with, and think like, the people whom they will be designing for in the future. For these community design charrettes, the students organized questionnaires and visual preference surveys to better evaluate and inform decisions such as program, aesthetic style, and material selection. Students also treated these charrettes as design reviews—providing a soft deadline for work and ideas to be completed and communicated. These events, where the students were often the minority, forced the students to not simply propose or suggest their designs, but to discuss the designs and invite feedback, to work collaboratively and engage the community so that the project could grow to be something of which everyone could be excited and proud.

The final design, taking full advantage of the southward-facing sloping site, exemplified a pair of connected 'bankbarn' homes with an accessible first floor (including kitchen, dining room, living room, and full bath) and dwelling rooms in the walk-out basement (three bedrooms and full bath). The design focused on open floor plans and adaptability so that the homes could change as the homeowners grew older. The site-specific design of the houses incorporated generous views to the Appalachian Mountains and ample solar exposure for Photovoltaic (PV) panels and passive solar heating. Every part of the home, from the orientation and site design, to the wall and roof construction, to the water and space conditioning systems were meticulously explored and researched by the team to assure the best possible decisions were made; there was no experimentation, per se, in the design. Rather, the house as a whole was designed to be a holistic product of research and experience. No new trials of construction are used in the house, but instead a wealth of research is brought together in ways not typically seen in current construction.



Fig. 3: Rendering of Entry for 2015 PSU Race to Zero Design Submission
Image Source: Penn State 2014-2015 “Heritage Homes” Race to Zero competition team.



Fig. 4: Variations and Adaptability in Floor Plans
Image Source: Penn State 2014-2015 “Heritage Homes” Race to Zero competition team.

The building envelope is an example of this combination of research and experience. The whole-house building envelope was rigorously studied with advisors and industry partners to determine the optimal solution between energy efficiency, cost of materials, durability, and constructability. Using both building science literature and educational resources by the DOE and Building Science Corporation and real-world experience provided by the industry partners and Green Building Advisor, the team was able to evaluate many different envelope assemblies to not only find a solution, but to find the best solution for this particular house. The envelope system is not a universal solution, nor is it intended to be; it is, however, the best solution decided by the team for the set parameters of the project (budget, material availability, typical

practices of construction, etc.). This kind of project and collaboration between students, researchers, and active architects/builders provided a multi-layered approach where conventions could be stretched and research could be practiced, not only enabling better designed homes, but a better and more rigorous way of learning for the future architects and engineers.

4. Outcome

In April of 2014, two students presented the project to a panel of judges (building scientists, academic researchers, and industry professionals) at the National Renewable Energy Laboratory (NREL) in Boulder, CO. The students interacted with their jury and other competing students from across the country, which allowed for an exchange of ideas and an assessment of the work that had been completed. The project received awards in design excellence and systems integration while also receiving a perfect score in the building envelope category. This validated the research and analysis that the team had completed over the year and ensured that, according to experts in energy-efficient home design, the duplex design was high performing, affordable, and build-able. The presentation also provided an opportunity for outside critique on the project and advice from people not immediately involved. Judges were able to inform the students not only what they had done correctly on the project, but also where improvements could be made. This was perhaps the most valuable as the project moved forward from competition to construction.

5. Next Steps

After the competition, the team met again to review the project, to go over the praises as well as the critiques by the jury. The advantage with having the competition incorporated into a formal class was for opportunities for review and go over lessons learned; rather than ending everything after presenting at NREL, the team could improve the design as well as really understand and fix any mistakes they had made during the design process. Immediately after the presentation at NREL the team prepared for their final community design charrette. Now that the competition was over, the design could loosen slightly—many of the technical and performance decisions would remain the same, but the formal design of the house could be refined to better suit the SCCLT and the community. During this final charrette, the team presented four slightly different options for the duplex combination, each of which had similar floor plan layouts and similar simulated performance but allowed for differences in site layout and building compositions.

This design work continued through the summer until a final site layout was determined by both the university design team (EEHR) and the SCCLT in early Fall 2015. Since the final layout was determined, EEHR students and faculty have been working to fully document the building so that the full design and performance intent can be understood and implemented by SCCLT with the assistance of professionals. EEHR has been working to design the drawing set to be both specific to this site and design, yet universal so that the knowledge and research that went into the drawings can be replicated on other projects. Adjacent to the drawing set, the team is compiling a research book that will provide a more thorough basis for why certain design decisions were made. The goal will be to publish both sets of documents so that builders and home-owners can make more conscious decisions about energy efficiency and home performance. After a successful fundraising campaign, SCCLT plans to select a local builder and begin construction before the end of 2016.

Involvement by EEHR doesn't end with the turning over of design documentation. Professor Iulo hopes to use the construction as a student learning opportunity, through arranging site visits and for interaction with the builders. Once design documentation is complete, the EEHR team will shift focus to evaluation and analysis of the duplex. While still in preliminary stages, initial goals will be to monitor home energy usage and learn about how the high-performance houses have influenced the owners—energy usage, lifestyle changes, etc. Even after the design is complete there will be much learning to be done by both the students and the faculty at Penn State.



Fig. 5: Rendering of Entry for updated duplex design (Fall 2015)
Image Source: Penn State EEHR.

6. Conclusions

What began as a consult for information about energy efficient design grew into an opportunity for significant research and a substantial student involvement activity, a thorough foundation of information about energy-efficient, zero-energy ready, housing, and a well-designed duplex for the community of State College. This project, although long and sometimes difficult in process, has been enlightening and beneficial for all parties involved, which speaks to the benefit of this kind of collaborative community design. Because of the 'real-world' aspect of the project, students were able to feel more engaged and that their design decisions were going to truly impact someone rather than be stored in a closet for half of a decade until the next accreditation visit. Students worked harder to make deadlines and researched more to defend their decisions; students could also interact with professionals in the design community and learn about how they design and how they make decisions. Students not only learned to be better researchers and designers in a broad sense, but they learned how to apply that knowledge to energy-efficient and affordable housing—something that has been, and will continue to be, an architectural issue.

The greatest achievement of this undertaking will be the completion of the houses. This project will be one in many that Penn State has completed over the past several years as a way to engage or give back to the State College community, distinguishing itself not only as an institution of higher education within State College but one that is part of and essential to the fabric and character of State College. This duplex will embody multiple years' worth of design and research that, otherwise, SCCLT would not have had access to. Symbiotically, the more engaged and more connected the students feel to the project and to SCCLT, the harder they work and the better the final design can be. This means that the SCCLT and the future residents receive a better house and the students receive a better education and experience. These community-based, 'real-world' design projects do more than simply teach students; they engage them in promoting healthier and better communities, teaching students not simply the how to design but the importance of design and the importance of connection to the surrounding environment.

7. Acknowledgments

The authors gratefully acknowledge the dedication, time, and support provided by all of the students, faculty, and industry partners involved in this project. The team leaders of the Penn State team for Race to Zero, Shahrzad Fadaei (2013-14) and Kyle Macht (2014-15), have been instrumental in the success of the project along with the support of Dr. Ali Memari, Sarah Klinetob Lowe, and The Pennsylvania Housing Research Center (PHRC). We would also like to thank Professor Scott Wing whose guidance and experience is essential to the success of this project, and graduated M.S. Architecture student Chauntel Duriez for her dedication to the project and to the State College Community Land Trust. EEHR would not be possible without the support of Penn State Institute for Energy and the Environment (PSIEE), Penn State

Christopher Hazel / ASES National Solar Conference Proceedings (SOLAR 2016)

Sustainability Institute, the Penn State Department of Architecture, and the College of Arts and Architecture
Hamer Center for Community Design Assistance.

8. References

- 7 group and Bill Reed, *The Integrative Design Guide to Green Building: Redefining the Practice of Sustainability*, Hoboken, NJ: John Wiley & Sons, 2009
- Penn State 2015 Race to Zero Team. (2015). "Heritage Homes: High Performance Living in Harmony with Community, Volume I. Report submitted to the U.S. Department of Energy NREL pursuant of the 2015 Race to Zero competition.
- SCCLT, State College Community Land Trust, "Who We Are;" retrieved June 24, 2016 from <http://www.scclandtrust.org/who-we-are.html>

Solar Electricity - Economics & Policy I and II



Comparing Carbon Fees with Existing Financial Incentives for Solar Electricity

John Schaefer

Consultant, Arcata, California

Abstract

This paper compares a policy of pricing carbon dioxide emissions with existing incentives for renewable energy, in effect juxtaposing disincentives for dirty electricity with existing, but varied, incentives for clean electricity. Among existing policies, the recently renewed investment tax credit (ITC) and accelerated depreciation are most important. The analysis here examines how high a carbon fee would be required to maintain profitability in the absence of the ITC.

The comparison is based on pro-forma financial projections of investors' returns for solar power generation in a typical setting, calculating the carbon fees needed to match existing incentives. Results offer perspective on how best to encourage clean energy with the application of carbon fees.

Keywords: *Financial incentives, solar electricity, carbon fees, tax credits, climate change, external costs*

1. Introduction

The recent extension of the 30 per cent investment tax credit (ITC) in the U. S. has probably saved the solar and wind industries from a severe downturn. With this incentive now in place for a few more years, a careful evaluation of long-term policies for clean energy is timely and appropriate.

U. S. energy policy has focused mostly on positive financial incentives for investment in renewable electricity. A more balanced energy set of incentives would discourage equally all sources of greenhouse gas pollution, not just encourage investments in clean electricity. Economic theory described by Pigou (1920) and Turvey (1963) suggests that the cost of damages to third parties be added to the price of a transaction between a buyer and seller, for example to discourage the use of dirty fuel. Thus, internalizing fossil fuel's damage or external costs could simplify existing complex incentives for clean energy, and cover all sources of carbon dioxide emissions.

Carbon fees have been applied with limited success as disincentives for carbon dioxide pollution, mostly outside the U. S. Legislative proposals within the U. S. have been made at local and federal levels. A key question is what should be the level of carbon fees.

2. Damages from Carbon Dioxide Emissions are Costly

Renewable energy sources are presently at a financial disadvantage because they are more expensive to build, and because cheap fossil fuels do not pay for the damage they do to the environment. Damages are calculated in dollars per tonne of carbon dioxide, which is used the indicator for all harmful emissions.

Damages from greenhouse gas emissions are now recognized as extensive: sea level rise, more violent storms, hotter and drier weather at some times in some locations, cooler and wetter weather in others, decreased agricultural production, international insecurity and migration, wider geographic ranges for

diseases, loss of species, and ocean acidification, to list a few. Climate change appears to be accelerating now at a rate that requires a more robust response than is possible with existing policies.

Dollar estimates of damages from greenhouse gases vary widely. Epstein, et. al. (2011) report that damages from coal-fired electricity range from \$75 to \$216 per tonne of carbon dioxide, with an average of \$143. Sumner, et. al. (2009) suggest a range of \$29 to \$221 per tonne. These ranges are too wide to be useful, except to note that they are higher than values closer to zero that are inherent in current pricing.

Ideally, more precise damage estimates would form a basis for public policy, but practical political considerations have in the past and will in the future probably limit adoption of such policy. In any case, the analysis here ignores such logic in making policy, and only considers the effect of carbon prices on the profitability of solar electricity investments.

3. Carbon Fees Better than Cap and Trade

Two types of public policy have been implemented to make fossil fuels more expensive: cap and trade, and carbon fees. Variations of cap and trade are universally complicated and have resulted in prices too low (around \$12 per tonne) to make a difference to fuel users (roughly 9 or 10 cents per gallon for gasoline) or to renewable electricity bidders (less than a penny per kWh in electricity). A major shortcoming in cap and trade as it has been implemented is the variety of allowances given to politically influential major polluters. Another shortcoming, which follows from the first, is a lack of certainty in prices that renewable energy investors can anticipate when they compete with polluters.

A simpler policy than cap and trade is to charge a predictable fee for all fossil carbon as it enters the economy, based on the tonnage of carbon dioxide produced when it is burned. Variations have been implemented in Europe, but the best example is in the Canadian Province of British Columbia, reported by Porter (2016). A rising carbon fee has turned out to be effective and politically popular since implementation in 2008. What made it successful was returning all revenue to citizens and companies in tax reductions. Fossil fuel use in the province declined by 17 per cent. The fee is capped at CD\$30 (about US\$23) per tonne.

Cap and trade policies and carbon fee policies generally cover all or most sources of carbon dioxide pollution (fossil fuel heating and transportation, for example) and do not just support solar and wind as the ITC does. Covering all sources is important, to avoid the economic distortions in the hodge-podge collection of current incentives.

4. Investors Seek Adequate Return and Predictability

In evaluating prospective investments in renewable energy, prospective investors use pro-forma projections of their initial expenditures and future cash flows to determine whether a project is financially profitable. If the return on investment, or the discount rate for which those cash flows yield a zero net present value, on these cash flows is sufficient, then the investment is attractive. If the return is too low or too uncertain, the investor will reject it. A carbon fee will raise the revenue earned from electricity sales and an investor's return on investment.

Issues in determining these pro-forma cash flows for solar (and wind) electric generation include:

- The initial investment, which depends on the cost per kW and system capacity;
- Revenue earned from electricity sales, which depends on the plant's capacity factor and the sales price per kWh;
- Operating costs, including maintenance, insurance and property taxes; and
- Income tax, which depends on tax rates, allowable depreciation, and tax credits.

5. Investors' Returns with Existing ITC

Examples here are based on average California conditions, where the dominant source of greenhouse gas for electricity generation is natural gas. California's generation mix is efficient, and its solar resource is

excellent. Other electricity sources include nuclear, hydro, and renewables, which emit no carbon dioxide. Natural gas prices below three dollars per million Btu in recent years make renewable electricity sources less financially attractive than they were before fracking. Results will be different in states where coal is still a major part of the mix, or where the solar resource is less favorable.

The first example is a typical leased California residential rooftop PV system, based on data from Bolinger and Seel (2015). A pro-forma cash flow is illustrated in Table 1, based on assumptions of 10 kW, \$3.00 per watt, 24 percent capacity factor, a 30 percent ITC, 5-year accelerated depreciation with third quarter in service, all equity financing, 20-year life, and 10 percent salvage. California data are taken from Energy Information Administration (2016), which provides 2014 information on electricity sales, revenues, generation, and emissions. Other varied incentives beyond the ITC and accelerated depreciation are not considered.

Revenue is calculated as the reduction in the homeowner's utility bill at 16.2 cents per kWh. The next-to-last row in Table 1 is the cash flow that establishes return on investment, which turns out to be 11.7 percent. Obviously the return would be more attractive with higher revenue, less attractive with higher installation cost, and less attractive with lower capacity factor. Thus, results will differ in other states.

Table 1: Pro Forma Cash Flow Statement for Leased California Rooftop PV, Existing 2016 Incentives, First Six Years of Twenty Years

Year	0	1	2	3	4	5	6-20
Sales (kWh)		21,024	21,024	21,024	21,024	21,024	21,024
Revenues		3,416	3,416	3,416	3,416	3,416	3,416
Initial investment	30,000						
O and M Plus Insurance	350	350	350	350	350	350	350
Cash Flow Excluding Taxes	-30,350	3,066	3,066	3,066	3,066	3,066	3,066
Depreciation	3,150	7,140	4,284	2,570	2,373	1,483	0
Investment Tax Credit (ITC)	9,000						
Taxable Income	-3,500	-4,074	-1,218	496	693	1,584	3,066
Tax Effects	-10,225	-1,426	-426	174	243	554	1,073
Cash Flow With Tax Effects	-20,125	4,492	3,493	2,893	2,824	2,512	1,993
Return On Investment	11.7%						

Tax issues dominate investors' returns. The ITC and tax deductions like depreciation are only useful to an owner with a tax liability. As a result the legal owners of leased systems are likely to be high-income entities.

Return on investment will be lower without the ITC, so the question addressed here is whether carbon fees could offset that loss. The effect of carbon fee will vary across locations and utilities, depending on the carbon content of its fuel mix and other factors. Therefore these results serve as examples and not as specific numbers for any given location or utility; but what is valid over all conditions is how important both the ITC and revenue with a carbon fee are for profitability.

Calculations of investors' returns, using the pro forma approach and the same California data, are summarized in Fig. 1, using the following examples:

- Ex. 1. Rooftop PV leased to homeowner, 30% ITC, with depreciation (Table 1);
- Ex. 2. Homeowner's rooftop PV, 30% ITC, no depreciation;
- Ex. 3. Rooftop PV, leased to homeowner, no ITC, with depreciation;
- Ex. 4. Homeowner's rooftop PV, no ITC, no depreciation.

Treasury bond rates as a fully secure investment are shown for comparison.

If the homeowner owns his system rather than leasing it, Ex. 2, he earns a 13.1 percent return. It exceeds the investor's return because the homeowner pays no tax on the savings in his electric bill. Because it's not classified as a business investment there are no tax consequences, and depreciation as a deduction is irrelevant.

Without the ITC, Ex. 3 and Ex. 4 show rates of return, 7.1 and 7.9 percent, which are enough less attractive that investors would probably reject them, especially for leased ownership. This illustrates why the uncertain, on-again, off-again incentives from the past were so harmful to renewable energy and why the 2015 ITC extension has been crucial for the solar and wind industries.

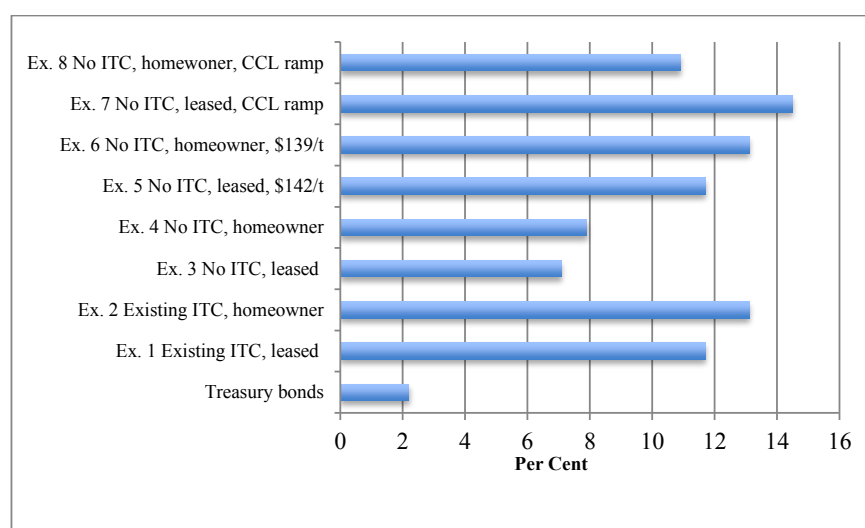

Fig. 1 PV Investors' Returns With ITC and Carbon Fees

6. Without the ITC, a High Carbon Fee Can Restore Investors' Returns

Building on the unattractive investment in Ex. 3 and Ex. 4 without the ITC, carbon fees can restore the return to investors and make those investments acceptable again. Carbon fees to offset loss of the current ITC are illustrated in Ex. 5 and Ex. 6, where the carbon fee is calculated as that which raises each investor's return to the same levels as in Ex.1 and Ex. 2.

An investor's return in Ex. 5 is same 11.7 percent as in Ex. 1, if revenue that the lessor earns incorporates a fee (on the carbon-burning utility) of \$142 per tonne of carbon dioxide, thus raising its cost per kWh. Similarly, a homeowner's return in Ex. 6 is the same 13.1 percent as in Ex. 2, if revenue he earns incorporates a (utility's) fee of \$139 per tonne.

An immediate increase in the carbon fee from zero to \$142 could be politically challenging. Ramping it up from a lower value is probably more palatable, and existing legislative proposals do start low and ramp up. The carbon fee in British Columbia began at a lower (CD\$5) level and ramped up to its current value of CD\$30 per tonne. Unfortunately it is capped at that level.

7. Without the ITC, Carbon Fee and Dividend Can Also Restore Investors' Returns

In the U. S. one proposal to ramp fees up is termed "carbon fee and dividend" by a San Diego-based non-profit, Citizens' Climate Lobby (CCL). All revenue would be returned directly to U. S. residents with a monthly check. Returning revenue to residents is logical because it is the residents, after all, who are most

harmful by climate change. The challenge will be convincing legislators that citizens should benefit with the dividend, instead of the government which may view the fee as a source of tax revenue.

Opponents may claim it's really a tax increase in disguise. Refuting that view, former Republican Cabinet Secretary George Schultz explains in Schultz and Becker (2013) his support for a revenue-neutral carbon tax. It's not a tax if all revenues are returned. Dr. Schultz is a member of CCL's Advisory Board.

Simplicity and ease of explanation are two virtues. Every ton of coal, barrel of petroleum or cubic foot of natural gas extracted from the ground or imported would require a payment to the U. S. Treasury, based on the carbon dioxide it will produce when burned. The Treasury would then return those funds to U. S. families, about \$280 per month per family of four after ten years. It would pay residents the way the Alaska Permanent Fund does. It would be a direct and practical application of Pigouvian economic theory, relying on markets rather than governments for investment choices.

CCL proposes a \$15 per tonne fee in the first year, followed by increases of \$10 per tonne per year. Collecting the fee would be straightforward because most fossil fuel is extracted in the U. S. by fewer than a thousand companies. Carbon fee and dividend (CFAD) would therefore cover all sectors of the economy and all sources of carbon dioxide, not just electricity. It eliminates distortions inherent in existing policies and provides a predictable, steadily rising revenue stream for all clean energy investors. Similarly, it discourages fossil fuel usage.

With CFAD in Ex. 7 the lessor-owner would earn a 14.5 percent return and the homeowner, Ex. 8, would earn a 10.9 percent return. Thus, CFAD as proposed more than matches the incentive that the current ITC provides for a lessor-owner. The homeowner's return is a bit less, but he'll also have revenue refunded to him in his family rebate dividend.

In ten years the gasoline price would rise by about a dollar. But CFAD plus expanded efforts in renewable energy and conservation provide additional benefits for the economy. Nystrom and Zaidi (2014) found that after ten years gross domestic product would rise by \$84 billion, employment would increase by 2.1 million, and carbon dioxide pollution would decrease by 33 percent. With cleaner air, early deaths would decrease by about 13 thousand per year.

8. Implementing Carbon Fees Won't be Easy

With approximately 30,000 members in the U. S. and overseas, CCL has been educating citizens and legislators about carbon fees since 2008. These efforts have met with some success; Davenport and Connelly (2015) report that a survey by Stanford University and Resources for the Future found that when citizens understand it, most would support a carbon fee that returns all revenue to citizens.

CCL is under no illusion that the transition to carbon fee and dividend will be easy, especially in the current political climate. Several bills incorporating carbon fees have been introduced in the Congress but none includes all of CCL's proposed features, and none has even had congressional hearings.

The ideal situation would be federal legislation and a uniform carbon fee across the country (or indeed across the world, because damages are worldwide), but a messier option might be a variety of state level carbon fees. In fact, the closest proposal to actual implementation is Washington State's initiative (I-732) starting at \$15 per ton, on the ballot for 2016. CFAD could be implemented in other states to meet EPA's Clean Power Plan, which only addresses coal. Indeed, a robust carbon fee and dividend policy would exceed its requirements and cover all sources of carbon dioxide.

9. Conclusion

Data from California suggest that replacing the ITC with carbon fees could be as attractive to clean electricity investors as the current ITC incentives, with fees as high as \$142 per tonne of carbon dioxide or with CCL's carbon fee and dividend. Carbon fees will be difficult to implement in the current political climate, but results here could be helpful in establishing future policy.

Carbon fees will place all fossil fuel emissions on an equal footing, thereby eliminating distortions in the current hodge-podge of incentives.

In the long term, prices with some carbon fee proposals are too low to maintain investor profitability, absent the ITC. To be effective, future proposals should include higher fees than those suggested heretofore, and certainly higher than those resulting from cap and trade. A steadily rising carbon fee and dividend as proposed by Citizens' Climate Lobby or in Washington State's I-732 ballot proposal could restore investors' profitability and might be used to offset future declines in the ITC.

References

- Bolinger, M. and Seel, J., 2015. *Utility-Scale Solar 2014: An Empirical Analysis of Project Cost, Performance and Pricing Trends in the United States*, Lawrence Berkeley National Laboratory.
- Davenport, C., and Connelly, M., 2015. Most Republicans Say They Back Climate Action, Poll Finds, New York Times, January 30.
- Energy Information Administration, 2016. from <http://www.eia.gov/electricity/data/state/>, accessed June 1, 2016. Data are from forms EIA-767, EIA-906, EIA-923, and EIA-861.
- Epstein, P. R., Buonocore, J., Eckerle, K., Hendryx, M., Stout III, B., Heinberg, R., May, B., Reinhart, N., Ahern, M., Doshi, S., Glustrom., L., 2011. Mining Coal, Mounting Costs: The Life Cycle Consequences of Coal, *Annals of the New York Academy of Sciences*, p. 1219.
- Nystrom, S., and Zaidi, A., 2014. *The Economic, Fiscal, Demographic and Climate Impact of A National Fee-and-Dividend Carbon Tax*, Regional Economic Models, Inc.
- Pigou, A. C., 1920. *The Economics of Welfare*, Macmillan, London.
- Porter, E., 2016. Does a Carbon Tax Work? Ask British Columbia, New York Times, March 2, 2016.
- Schultz, G., and Becker G., 2013. Why We Support a Revenue-Neutral Carbon Tax, Wall Street Journal, April 7, 2013.
- Sumner, J., Bird, L., and Smith, H., 2009. *Carbon Taxes: A Review of Experience and Policy Considerations*, NREL, Boulder CO.
- Turvey, R., 1963. On Divergences Between Social Cost and Private Cost, *Economica*, N. S.



Conference Proceedings



ASES National Solar Conference 2016

San Francisco, CA, USA July 10-13, 2016

The Hazards of Exponential Growth for the Solar Industry – and How Innovating Stronger Business Models is Key to Survival

Evan I. Schwartz

Innosight, Lexington, Massachusetts (USA)

Abstract

Living through exponential growth can be both exhilarating and hazardous. The solar industry has experienced both sides of this challenge. Installed solar capacity has grown globally from barely 1 gigawatt in 2000 to over 5 gigawatts in 2005 to an expected 320 gigawatts by the end of this yearⁱ, as costs have plummeted by 70 percent over the past decade.ⁱⁱ Forecasts now call for a tenfold power surge, to 3,000 GW, by 2030. Growth that multiplies this fast can be both deceptive and dangerous to those who depend on the sustainability of sustainability. At the same time that new capacity has been roughly doubling every year, we've seen a string of business failures, most notably the news that the industry's largest player, SunEdison, has fallen into bankruptcy with \$16 billion in liabilitiesⁱⁱⁱ, one of the largest non-financial business failures in history. There are red flags and warning signs that put the entire industry at risk. The precarious financials of Solar City recently induced founder Elon Musk to arrange for his other company, Tesla Motors, to acquire it in a financial rescue. The solar industry needs to come to terms with the fact that growing at such a breakneck pace with even slightly wrong business models can be a "train wreck," as one former CEO put it, with companies collapsing into bankruptcy faster and faster. The solar sector needs to focus as much effort on innovating the way it makes money as it does on innovating the way it produces technology. This paper highlights the obstacles that industry leaders face while also pointing the way toward solutions.

Keywords: *Business model innovation, solar capacity, power purchase agreement, photovoltaics, exponential growth, SunEdison, SolarCity, Elon Musk, Tesla Motors, battery storage, Sonnen, transactive energy.*

1. Introduction

Living through exponential growth can be both exhilarating and hazardous. The solar industry has experienced both sides of this challenge. Installed solar capacity has grown globally from barely 1 gigawatt in 2000 to over 5 gigawatts in 2005 to an expected 320 gigawatts by the end of this year^{iv}, as costs have plummeted by 70 percent over the past decade.^v Forecasts now call for a tenfold power surge, to 3,000 GW, by 2030^{vi}. Growth that multiplies this fast can be both deceptive and dangerous to those who depend on the sustainability of sustainability. At the same time that new capacity has been roughly doubling every year, we've seen a string of business failures, most notably the news that the industry's largest player, SunEdison, has fallen into bankruptcy with \$16 billion in liabilities^{vii}, one of the largest non-financial business failures in history.

Ignoring red flags and warning signs put the entire industry at risk. Another case in point involves how the precarious financials of Solar City induced founder Elon Musk to arrange for his other company, Tesla Motors, to acquire it in an attempted rescue. The solar industry needs to come to terms with the fact that growing at such a breakneck pace with even slightly wrong business models can be a "train wreck," as one former CEO put it, with companies collapsing into bankruptcy faster and faster. The industry needs to focus as much effort on innovating the way it makes money as it does on innovating the way it makes panels and other technologies.

To do so, we need to understand how we arrived at this state of high growth and high peril. Ten years ago, I served as writer and producer for *Saved by the Sun*^{viii}, a documentary which aired on the NOVA science series on PBS and has since been seen by about 20 million people on television and online. For me, one of the biggest *aha!* moments in the filming came when we followed a little-known entrepreneur named Jigar Shah onto the roof of a Whole Foods supermarket, where he explained how the store didn't need to purchase the solar panels up there, just as consumers don't need to purchase power plants that run on coal or natural gas. Rather, the store would simply pay for the electricity generated on an ongoing basis for the next 20 years. His startup, SunEdison, had come up with the business model innovation that seemed to unlock the growth equation for an industry that had been struggling to take off for its entire history: No money down, yet totally predictable costs for clean energy while also protecting consumers from rising fossil fuel prices.

2. Envisioning exponential growth

The power purchase model seemed brilliant up on that one roof, but it didn't take into account the exponential growth that would help unleash. Indeed, since exponential growth is so rare, the human mind often has trouble processing it. To envision that kind of growth, imagine a pond with clear waters and a single green lily pad on the surface. Now imagine that the sunlight helps the number of lily pads to double each day for a month—so that there are two pads on the second day, four on the third, eight on the fourth, and so on until the entire pond is covered lily pads by the end of the month. The paradox is that you would hardly notice that such rapid proliferation was even happening during the first, the second, and even the third week. Even on the 25th day, the pond would only be *one-sixteenth* covered with lily pads.

In terms of solar capacity, we are still in the second week of the month, so to speak. Solar sources only reached supplying 1% of energy needs in the U.S. and globally in 2015.^{ix} Yet by 2050, many forecasters are painting a picture of solar as the planet's leading source of energy,^x meaning that solar will fast become a trillion dollar market in a world that desperately needs to reduce its carbon emissions in order to avert the worst ramifications of climate change. The Paris Climate Agreement lays out the risks, goals, and incentives, but the solar industry won't be able to get there without the right business models.

3. The precarious state of the solar industry

Before we get to the solutions, it's vital to understand the scope of the problem, as experienced first by SunEdison and then by Solar City. The good news is that the bankruptcy of SunEdison had nothing to do with the viability of solar as a technology. Founded in 2003, the startup was privately held and profitable after its first five years. Although it employed only 300 people and completed just a few hundred installations, the Maryland-based company was already America's largest solar energy supplier. Then, in November 2009, semiconductor manufacturer MEMC (for Monsanto Electronic Materials Company) acquired it for \$200 million. By then, MEMC had an impressive global scope, manufacturing and supplying solar cell technologies to major partners in Germany, China and Taiwan. Founder Jigar Shah exited the company as the MEMC executives took over.

What happened next was a classic case of hubris and a blind belief in financial engineering. MEMC changed its name to SunEdison as its executives came up with a dangerous model called a "yieldco." The idea was that when a solar energy project was sold, investors could essentially look at it as a bond that would create a steady stream of payments over its lifetime. The investment money would help offset the collateralized debt that such solar projects required. But any back of the envelop calculation could show the ramifications of this. If you completed 10,000 residential, commercial or utility-scale solar installations at an average cost of \$100,000, you would incur about \$1 billion million in debt, which required borrowing. Under this model, SunEdison's TerraForm yieldco's acquired even more solar projects, piled on more debt, and sold their yield streams to investors in a way not dissimilar to the way Wall Street packages and sells mortgage bonds.

There's nothing wrong with solar panel debt, just as there's nothing wrong with home mortgages. The problem comes in when financial engineers package that debt into new kinds of investment vehicles. Since the 2008-09 financial crisis, many institutional investors have learned their lesson, and problems with SunEdison's yieldco model were becoming known.

Just as investors were losing confidence in the model, SunEdison overreached even more, agreeing to acquire rival Vivant Solar for \$2.2 billion in July 2015. Already overstretched, SunEdison couldn't find investors who were willing to foot the bill. SunEdison's stock plunged from about \$31 to near zero over the next year as the entire scheme imploded into lawsuits and a bankruptcy filing which listed \$16 billion in liabilities. Most of TerraForm's solar bonds were downgraded by Standard & Poor's to junk status.

"You are combining a relatively new energy sector with a brand new investment vehicle," Dan Reicher, executive director of Center for Energy Policy and Finance at Stanford University, told *Fortune*. "We shouldn't be terribly surprised that we've had some problems."^{xi}

4. How the fallout could cause a collapse in cleantech

That leaves SolarCity as the largest solar power installer in the U.S. By the end of 2015, SolarCity installed nearly 2 GW of solar capacity. Installations grew 54% last year as the total cost per watt hit another record low of \$2.71. But SolarCity posted a net loss of \$375 million.^{xii} Although that loss was narrower than the year before, it still amounted to losing more than \$1 million per day installing solar panels.

As the founder of three concurrent startups, Tesla Motors, Space-X and SolarCity, Elon Musk is a bold and brilliant entrepreneur. SolarCity has been raising money from a variety of sources, but Musk went a bridge too far last when he began selling "solar bonds" to sister company Space-X, including a \$90 million sale in the spring of 2016.^{xiii} The rationale was that Space-X gets paid in advance for many of its rocket projects, so that it had the cash on hand to make such an investment. But this couldn't go on for long.

In June 2016, Musk announced that Tesla Motors would acquire SolarCity for \$2.8 billion. "It's now time to complete the picture," said Tesla's announcement. "Tesla customers can drive clean cars and they can use our

battery packs to help consume energy more efficiently, but they still need access to the most sustainable energy source that's available: the sun.^{xiv} While powering electric cars with the sun is no doubt the way to go, the entire Tesla ecosystem is now put in immediate peril by SolarCity's faulty business model.

All told, this shifting of solar projects from one balance sheet to another is creating a financial bubble, not unlike the mortgage bond implosion of 2007-09. If the industry expects to grow tenfold over the next 15 years, this cannot continue. Indeed, the stakes are higher than even what happened in the financial crisis, since the fallout here could cause a collapse in clean energy investment that is critical for averting the worse effects of climate change.

"Solar has been a boom-and-bust business to date," said retiring First Solar CEO Jim Hughes.^{xv} Warning of an industry "train wreck," he added, "I think everybody would like us to move to a little more stable environment."

5. Five principles for the future of solar business models

In order to prevent a damaging industry meltdown, the industry would do well to embrace these five principles for not safer business models that that harness key trends based around customer needs.

1. **No new financial instruments for solar.** It's alluring to say that solar bonds are backed "by the power of the sun," as SolarCity says in press statements. But there is no real reason to treat solar any differently than any other kind of capital equipment. Spinning solar bonds off into "yieldcos" can be deadly, as SunEdison found out. There is no reason to create a new class of securities.
2. **Solar installers that don't have sufficient capital should simply partner with banks.** We need to decouple debt risk from the business models of solar installers. SolarCity and companies like it have other ways to make money. They can take the financing off its balance sheets. It's true that the attractive depreciation schedules for renewable energy project make self-financing alluring, but installers should find ways to work with banks so that the accounting not only benefits them but also helps end consumers.
3. **Disrupting the bigger energy business—transportation—is the key to fueling sustainable growth.** While the total market for electricity is huge—over \$350 billion annually in the U.S.—what's equally huge is the market for gasoline, which also amounts to a U.S. market of about \$350 billion per year. This is where it's strategically smart to combine SolarCity and Tesla. At its gigafactory in Nevada, Tesla will ramp up production of its PowerWall storage batteries. When you charge your car with a solar-powered battery, you are taking money out of the pockets of the oil companies. What's more, this distributed clean energy can be produced and stored during peak solar hours. That's why the future of solar lies in the unification of these two previously separate energy systems.
4. As a result, **the storage battery becomes the linchpin of the future business model.** Tesla isn't the only company betting big on this market. German startup Sonnen shipped its 10,000 battery earlier this year.^{xvi} In one way, the battery to the solar industry is what the cable box is to the cable industry: an essential piece of hardware that can be purchased or rented for a monthly fee but can also lock you into one supplier. Solar companies need to figure out how to build value-added services on top of the battery, in the same way that cable companies really make their money by bundling bandwidth and content.
5. Which brings us to the final principle: **that he who supplies the best remote control or mobile app wins.** Just as Uber is disrupting traditional taxis and Apple and Netflix are disrupting cable companies with better interfaces and better business models, there is still much to be figured out in terms of what the ideal solar business model will look like. So far, the transactive energy concept holds out much promise. What started

out as a way for the grid to manage and supply distributed energy resources^{xvii} is evolving into a way for end-consumers to control and monitor their energy needs in the palm of their hand, with mobile apps that track their photovoltaics, combined heat and power systems, battery storage, and electric vehicles. This is where the real action and money should be made, not in dangerous new financial instruments.

6. Conclusion

We have reached a bizarre paradox in the solar industry: unprecedented, exponential growth is also leading to disastrous financial failures with more to come unless things change. Solar installation financing should be left to banks and other well capitalized institutions. The solar industry itself should instead focus on evolving smarter business models that harness new opportunities that matter to consumers.

7. References

-
- ⁱ Greentech Media report: <http://www.greentechmedia.com/articles/read/gtm-research-global-solar-pv-installations-grew-34-in-2015>
- ⁱⁱ Solar Industry Association report: <http://www.seia.org/research-resources/solar-industry-data>
- ⁱⁱⁱ FORTUNE: <http://fortune.com/2016/04/21/sunedison-files-bankruptcy-protection/>
- ^{iv} Greentech Media report: <http://www.greentechmedia.com/articles/read/gtm-research-global-solar-pv-installations-grew-34-in-2015>
- ^v Solar Industry Association report: <http://www.seia.org/research-resources/solar-industry-data>
- ^{vi} <https://www.theclimategroup.org/what-we-do/news-and-blogs/bloombergs-new-energy-outlook-2015-report-predicts-phenomenal-renewable-energy-growth>
- ^{vii} FORTUNE: <http://fortune.com/2016/04/21/sunedison-files-bankruptcy-protection/>
- ^{viii} The documentary is available for streaming here: <http://www.pbs.org/wgbh/nova/tech/saved-by-the-sun.html>
- ^{ix} <http://cleantechnica.com/2015/06/12/solar-power-passes-1-global-threshold/>
- ^x Renewables 2016; Global Status Report, by REN21, the Renewable Energy Policy Report for the 21st Century
- ^{xi} <http://fortune.com/2016/04/25/sunedison-drowned-debt/>
- ^{xii} See <http://investors.solarcity.com>
- ^{xiii} <http://venturebeat.com/2015/03/30/elon-musks-spacex-buying-90-million-of-elon-musks-solar-city-solar-bonds/>
- ^{xiv} <https://www.teslamotors.com/blog/tesla-makes-offer-to-acquire-solarcity>
- ^{xv} <http://www.greentechmedia.com/articles/read/First-Solars-Jim-Hughes-Touts-a-Bulletproof-Balance-Sheet-Warns-of-an-l>
- ^{xvi} <http://www.greentechmedia.com/articles/read/sonnen-ships-its-1000th-battery-putting-pressure-on-tesla-and-utilities>
- ^{xvii} <https://www.greenbiz.com/blog/2013/06/04/transactive-energy-helps-buildings-strengthen-grid>



SMUD Solar: A Roadmap For Utilities in Transition

Warren Schirtzinger¹, Donald W. Aitken², Donald E. Osborn³, and Steven J. Strong⁴

¹ High Tech Strategies, Inc., Seattle (United States)

² Donald Aitken Associates, Ajijic (Mexico)

² Spectrum Energy Development, Elk Grove (United States)

² Solar Design Associates, Harvard (United States)

Abstract

There is near universal agreement that the utility sector is in the midst of a transformation. The 100-year-old model of centralized generation and one-way power flow is being disrupted by alternative energy technologies that enable customers to generate and store their own electricity.

Recent surveys of utility executives confirm the conclusion that traditional utility business models need to change as a result of these (and other) disruptive forces. New technologies, renewable portfolio standards, and federal carbon regulations have created a minefield of issues and challenges for the electric utility industry.

As incumbent utilities grapple with the daunting challenge of reinventing themselves, the pioneering work at Sacramento Municipal Utility District (SMUD) provides a credible foundation from which to construct a new-age road map for utilities going forward. Methods and strategies employed by SMUD in the 1990s and 2000s can help utilities of all types successfully navigate this disruptive transition to a clean energy future.

Keywords: solar, clean energy, technology adoption, disruptive innovation, alternative energy, electric power, grid-connected photovoltaics, distributed generation, commercialization, dispatchable storage

1. Introduction

With the closing of the Rancho Seco nuclear power plant acting as a catalyst, Sacramento Municipal Utility District (SMUD) established a solar program with the mandate to promote the commercialization of grid-connected PV for both utility and end-customer applications. From 1992 through 2002, SMUD's solar program had a profound effect on the development and transformation of the entire solar/PV industry and earned SMUD a worldwide reputation for its affordable, clean, renewable energy programs.

The unplanned transformation of an electric utility, caused by the loss of its principal source of power, presents a rare opportunity to study and learn about how a utility can make the transition to renewable energy. An examination of SMUD's transition strategy shows the utility focused primarily on nurturing key markets with broad potential, using its buying power to lower the cost of photovoltaic panels, a technique referred to as Sustained Orderly Development and Commercialization (SODC). SMUD's transition plan also included offering a complete, standardized solar system "package" to residential homeowners in order to reduce the perceived risk of using a new technology.

The ability to field and interconnect large volumes of small-to-large PV systems on a utility's grid in a

simplified fashion and without adverse effects was proven. The willingness of mainstream customers to employ PV on a large scale – going well beyond early adopters – was demonstrated.

This paper describes the technical, economic and cultural techniques used by SMUD during a time when it was forced to replace nuclear power with renewable energy. Based on the experience and results achieved at SMUD, our goal is to provide valuable insight and a roadmap for all utilities in transition, looking to navigate their way to a clean energy future.

2. An Unplanned Transition

The Sacramento Municipal Utility District (SMUD) is one of the ten largest publicly owned utilities in the United States and serves approximately 1.4 million people in a 900 square mile service area in the Sacramento, California metropolitan area.

On June 6, 1989, Sacramento became the first, and only, community in the world to shutter a nuclear power plant by public vote. The plant was closed during an era of enormous concern about nuclear safety and economics. Closing the Rancho Seco Nuclear Plant initially forced SMUD to buy more than half its power from neighboring utilities. SMUD needed to replace the power generated at Rancho Seco and management explored a variety of options, with and without SMUD-owned resources, ultimately deciding to pursue a diversified portfolio of power sources, including wind and solar, along with a strong emphasis on conservation and energy efficiency.

3. Transition Strategy

The Solar Program at the SMUD was established with a mandate to promote the commercialization of grid-connected PV for both utility and end-customer applications. SMUD's transition to solar was focused on distributed generation at both customer and SMUD sites. While the utility put more effort into their residential solar applications than into any other single area, SMUD also developed a comprehensive set of "non-residential" grid-connected applications of PV that included: commercial building rooftop systems, distribution support at substations and electric vehicle recharging stations. But the efforts at SMUD that ignited the current solar industry revolution were based on the residential market through the SMUD's "PV Pioneer Program."

SMUD had already installed utility-scale PV arrays in 1984 (Rancho Seco I) and 1986 (Rancho Seco II). So their level of technical understanding and familiarity with solar electric systems was advanced and growing. This made the transition to renewables less of an unknown. The greatest challenge for SMUD was applying their experience to distributed generation at customer sites.

The SMUD Solar Program, running from 1992 to 2002, was established to implement a broad range of grid-connected PV applications on both sides of the utility meter and as a compliment to SMUD's extensive energy efficiency program. At the time the grid-connected PV market was virtually non-existent, consisting of only a few demonstration projects, so the high cost of PV was recognized as a barrier to widespread adoption.

There were two main facets of SMUD's transition strategy. The first was to use the utility's buying power to lower the cost of photovoltaic panels through a sustained multi-year commitment to purchase a substantial volume of PV each year with prices declining with each yearly block of purchases. This annual commitment to purchase was nearly one megawatt of PV at a time when the entire grid-connected PV market was measured in kilowatts. The second was an initiative to develop and improve solar business practices. This included creating a compelling whole product for mainstream customers by offering a complete, standardized solar-panel package while simplifying both interconnection and permitting.

As a result SMUD saw substantial reductions in PV project costs and began the process of transitioning PV from a 'public goods,' subsidized resource to a self-sustaining, commercialized resource for domestic, grid-connected applications. Through these market transformation activities SMUD was able to dramatically lower the cost of PV for its customers, stimulate local economic development, and begin the building a long-term market for grid-connected PV in the US.

Bulk purchase commitments provide PV manufacturers with the assurance of a future market that they need to expand their manufacturing capabilities and achieve cost reductions. This mitigation of risk and stimulation of new production, plus the effect of technology improvements associated with new production processes, combine to create structural changes that lead to lasting benefits. Production increases result in price reductions

that are permanent and provide a lasting stream of benefits, unlike demonstration projects or large one-time purchases.



Fig. 1: SMUD's two-part strategy to encourage the adoption of solar power

The SMUD Solar Program included the first multi-year, large volume, broad based, customer sited, PV applications through its “PV Pioneer” Program. Through the sustained, multi-year, high volume purchase and fielding of PV systems, significant cost reductions and improved system performance results were achieved. The ability to field and interconnect large volumes of small-to-large PV systems on a utility’s grid in a simplified fashion and without adverse effects was proven. The willingness of utility customers to adopt PV on a large scale – going well beyond early adopters – was also demonstrated.

During the first years of the PV Pioneer Program the homeowner simply lent his roof -- plus paid a small green energy surcharge to SMUD -- with the PV connected to the utility side of the meter. This gave SMUD experience in the application of distributed PV resources within its system, and provided the opportunity to gain the confidence of ratepayers for having PV on their homes.



Fig. 2 : Early SMUD PV Pioneer I System with SMUD's D. Osborn and D. Collier

This evolved into the “PV Pioneer II” program, in which the homeowner purchased their system for a subsidized amount and realized the benefit of power generation on their side of the meter, in a “net metered” configuration with the grid. This transition had the additional benefit that as the PV Pioneer I installations were “utility owned power plant,” SMUD acted as the “permitting agency” avoiding the complications of permitting process not familiar with PV. This created an experience base for permitting agencies to benefit from once the PV Pioneer II (customer owned) program began and the traditional permitting agencies were then responsible. This also helped to develop the market infrastructure in the private sector needed to respond to the growing customer demand for PV systems in Sacramento.

It is important to note that when SMUD started its PV Pioneer I Program, there was no pre-existing, grid-connected market in place so SMUD was not using its monopoly status in unfair competition in an existing, viable market. Indeed, SMUD developed the grid-connected market and then nurtured the transition from the utility as the service provider to one of supporting a new and developing marketplace of private suppliers through the PV Pioneer II Program.

The fact that Sacramento could shutter its biggest energy source overnight and continue growing on a mix of conservation and renewable power suggests there are many options and alternatives for utilities going forward. The key to guiding any transition is an understanding of the dynamics of technology adoption and market

transformation, which are described in the following section.

4. A Framework for Technology Adoption

Mainstream technology marketing, as it is widely practiced today, is fundamentally a combination of models and techniques that are adaptations of earlier work. The technology adoption lifecycle for example is an extension of an earlier model called *the diffusion process*, which was originally published in 1957 by Joe M. Bohlen, George M. Beal and Everett M. Rogers at Iowa State University¹.

Everett Rogers extended this popular theory about how, why, and at what rate new ideas and technology spread in his book *Diffusion of Innovations* in 1962².

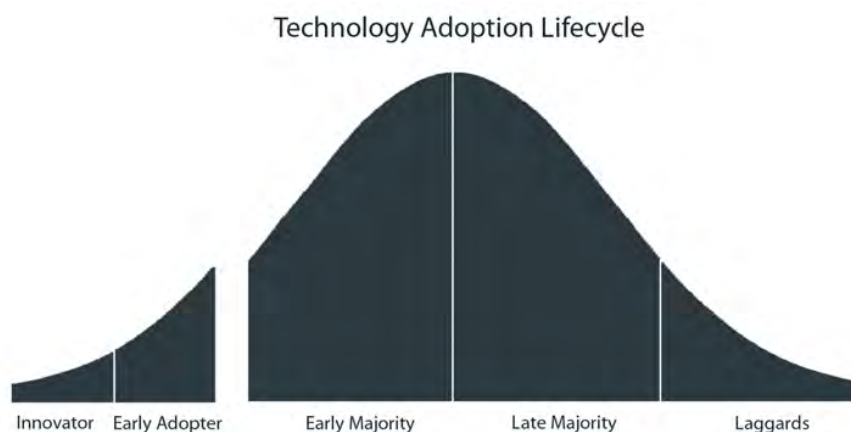

Fig. 3: The technology adoption lifecycle model

In 1989 diffusion theory was updated again, this time by Lee James and Regis McKenna while working with technology companies in Silicon Valley and the Pacific Northwest⁵. The updated model was called the “Technology Adoption Lifecycle,” which in turn led to development of the “Crossing the Chasm” marketing model that later became the subject of a book by the same name, written by Geoffrey Moore in 1991⁶.

Other modern day marketing models include Ted Levitt’s “Total Product Concept³” (1980) that was adapted for technology products by Regis McKenna in his book *The Regis Touch* (1985)⁴. McKenna’s book emphasizes the process of diffusing technology across various classes of users ranging from innovators to early adopters to late adopters and laggards and the corresponding evolution of the “Whole Product.”

Despite their relative age, several of these books are still required reading in entrepreneurship courses at Stanford, UC Berkeley, Harvard, and MIT. Technology adoption theory is taught in all business schools worldwide.

5. A Model for Mainstream Market Adoption

The most common technology adoption framework in use today -- Crossing the Chasm -- is a seven-element program designed to accelerate adoption of an emerging technology by a mainstream audience causing it to be accepted and put into practice. According to the framework, any program designed to encourage mainstream market acceptance must contain the following seven elements:

1. Select a Target Customer -- Select an identifiable economic group of buyers and focus your efforts on satisfying that specific segment of the mainstream market
2. Understand the Compelling Reason To Buy -- Ensure that the target market has a compelling reason to buy the new product or technology, as soon as possible
3. Define the Whole Product -- Determine what makes the product "complete" in the eyes of your initial target customer. The whole product is the complete set of products and services required by the target customer to achieve his or her compelling reason to buy. This often means the core product/technology must be augmented with a variety of services and ancillary products to become complete.

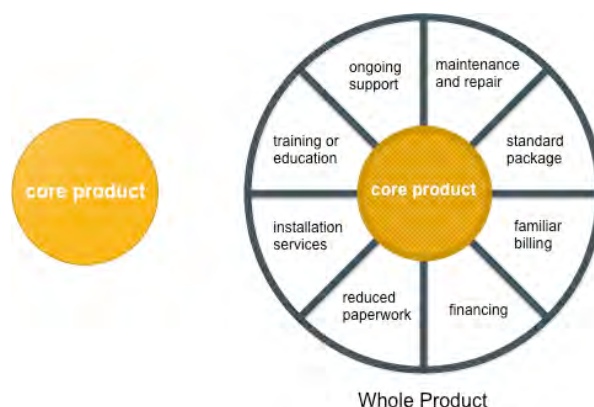

Fig. 4: The Whole Product Concept as applied to SMUD's PV Pioneer Program

4. Recruit Partners and Allies -- It is rare for a single organization to be able to deliver every piece of a whole product. So the only way to satisfy the whole product requirement is to an organization must recruit the necessary partners and allies
5. Use Appropriate Pricing -- Price must be appropriate for the category of product being offered, and the financial transaction needs to make it is easy for the customer to buy.
6. Select Familiar Channels of Distribution -- Mainstream customers have very strong preferences regarding who they buy from and they especially like to buy from people and channels they already know. You must present your new product via a familiar channel
7. Communicate the Right Messages -- Position the organization and the offering in a way that reduces risk in the eyes of the buyer. The organization must be seen as a credible provider of products and services to the target market.

6. SMUD's Technology Adoption Scorecard

The SMUD Solar Program met or exceeded the requirements in *all seven* of the areas of the Crossing the Chasm technology-adoption framework. This achievement indicates SMUD was able to fully understand the personal needs, requirements and motivations of a mainstream audience. SMUD recognized the pragmatic and risk-averse nature of the mainstream buyer and designed a complete offering that leveraged all of the inherent advantages of a utility.

- ✓ Select a Target Customer -- SMUD selected homeowners as their principal target market and launched a two-phase program (PV Pioneer I and II) designed to place solar on residential rooftops. This emphasis on homeowners along with small businesses complimented the sustainable orderly development initiative by allowing SMUD to purchase PV modules by bid in substantial quantities, which progressively reduced the cost of their installed PV systems.
- ✓ Understand the Compelling Reason To Buy -- It is interesting to note that the event that forced a transition to renewables at SMUD, also became the compelling reason for residential homeowners to adopt solar power. At the time there was enormous concern about nuclear safety both locally and around the world. The Rancho Seco Nuclear Power Plant was nearly identical to the Three Mile Island reactor. Rancho Seco also had a very checkered operational history leading to substantial rate increases. The concern about the safety of nuclear power caused SMUD ratepayers to demand an alternative.
- ✓ Define the Whole Product -- It is in this area where SMUD absolutely excelled. SMUD augmented a standardized 4-kilowatt solar system with a long list of intangible product attributes – streamlined permitting, educational materials and programs, installation services, ongoing support, convenient billing, etc. The result was a complete offering for mainstream homeowners.
- ✓ Recruit Partners and Allies -- SMUD obviously recruited the necessary installers, contractors and equipment

suppliers needed to create a whole product. However SMUD's list of partners and allies included local governmental agencies that helped streamline the permitting process. In many cases, this meant empowering a local jurisdiction so that administrative processes could be expedited.

- ✓ Use Appropriate Pricing -- Initially SMUD asked customers to pay a \$4 per month premium to host a SMUD-owned solar array on their rooftop. With PV Pioneer II the customer could purchase a 2 kW solar array for \$6,000. These prices were appropriate for the category at the time each program was active.
- ✓ Select Familiar Channels of Distribution -- At the start of the SMUD PV Pioneer Program, there was no pre-existing, grid-connected PV market. As a result SMUD could use its well established relationship with customers already familiar with their local utility as a provider of electric power providing an important level of confidence with what was perceived as a new, untested technology without the profound issues of unfair competition in an established marketplace. SMUD, under PV Pioneer I, first solicited participating customers to provide their roofs for a SMUD owned PV "power plant," building market awareness, experience, and confidence while beginning to build the capabilities of marketplace providers. Then SMUD transitioned to the PV Pioneer II program, where customers were buying the PV systems through SMUD incentives and guidance from a growing body of providers. Throughout, the SMUD customer had the assurance of "going solar" with the confidence of SMUD's involvement.
- ✓ Communicate the Right Messages -- SMUD recognized a critical characteristic of the mainstream audience they were targeting, that people could "go solar" safely and with ease. People have never had to evaluate multiple energy vendors before selecting a supplier let alone evaluate a new technology mix. So SMUD used their position as a known provider of electric power and communicated from the position of a trusted advisor to the homeowners in Sacramento. This was a very powerful positioning strategy.

7. Commercialization Strategy

In considering the commercialization strategy to pursue, many have looked at the solar programs in Japan and concluded that substantial "buy-down" incentives were the key to success of commercializing grid-connected PV. Others concluded from programs in Germany that a high "feed-in" tariff was the key success factor. However, it was not the specific incentive chosen that made these programs succeed. Rather, it was how each program was implemented and sustained over time.

In order to accelerate the long-term cost reductions required for full commercialization, the solar industry needed reliable, substantial, growing and sustained market volume. And manufacturers need long-term, reliable programs in order to invest the capital required to ramp up production to meet that demand. Therefore, to be effective, any renewable energy commercialization program, whether national or local, must include the following attributes:

Sustained: sustained over a period sufficient to result in market and manufacturing changes – typically at least a decade. Gaps in incentive funding can quickly gut its effectiveness.

Orderly: policies that have sensible consistency over time, and are not revisited, or turned on or off, in each year.

Substantial: substantial enough to affect market changes – resulting in a series of doublings of the market, perhaps in concert with other initiatives. Sufficient incentive funding for long-term success must be assured, but too large incentives are counterproductive.

Predictable: predictable over the initiative period so investors, manufacturers, and suppliers know what the details and ground rules are for the entire period, including the multiyear program plan.

Credible: credible with the investors, manufacturers, and dealers so they are confident in making the needed investments to significantly expand supply. If the investor does not believe the multiyear program is credible, if funding is uncertain or may have significant funding gaps, the incentive will be ineffective in expanding supply.

Ramped: ramped down over time to exert constant downward price signals and avoid an "incentive cliff" at the end of the incentive period. This also stretches out the incentive funds and yields increasingly greater returns for the incentive program.

The lack of any of these factors will result in an incentive policy that is ineffective or even counter-productive.

The problems experienced in many early statewide California programs were almost exclusively due to funding gaps and start/stop cycles. This lack of consistency reduced the investment in the PV delivery infrastructure and lowered the program's impact on cost reductions. Once these issues were corrected, programs such as the California Solar Initiative began to grow explosively.

Any public policy aimed at accelerating the commercialization of a discontinuous innovation must itself be sustainable and lead to permanent changes. It must expand the market, stimulate new production and lower costs in ways that becomes embedded and structural. What are needed are sustained incentives and processes that will expand supply, help reduce transactional costs, and lower installed costs over time.

A successful transition to a new energy strategy also depends on human factors. To be successful it must have:

1. **The proactive support at the highest management levels.** Market transformation requires a long-term commitment and is disruptive to many traditional business plans. At SMUD, the General Manager (S. David Freeman) and the Board (led by Board President Ed Smeloff) made the solar program a very high priority and also provided high-level support.
2. **A dedicated, knowledgeable, and committed program team.** The manager of SMUD's Solar Program (co-author Donald Osborn) had extensive experience in solar that allowed him to develop, lead, and manage a dedicated team (including Dave Collier who was the lead engineer on Rancho Seco I & II) that was given ownership and "cradle to grave" responsibility for the entire duration of the program.
3. **A commitment for the long run.** A successful transitional strategy is a multi-year effort that is by its very nature, disruptive, and contrary to conventional business practices. Through the support of SMUD's General Manager and Board, the solar program had the flexibility and time to implement a strategy that looked far beyond the next quarter or annual budget cycle.
4. **Builds on previous work and forms a basis for follow-on action.** The SMUD Solar Program built upon key development and demonstration efforts of the 1980s; including the Solar Design Associates/New England Electric PV neighborhood in Massachusetts (led by co-author Steven Strong) and PGE PV Demonstration and Analysis Programs including Howard Wenger and Tom Hoff who provided the economic analysis showing the "stacked benefits" of the SMUD PV deployments. In turn, the SMUD Solar Program spearheaded efforts to broaden its impact through collaborative efforts with other utilities to gain broad acceptance of grid-connected, distributed generation. This included PVUSA, the solar test facility established by the US Department of Energy and a consortium of utilities, plus the formation of the Utility PV Group, which became the Solar Electric Power Association. The SMUD Solar Program incorporated the principles of SODC that were originally developed by Donald Aitken (co-author) for the California Energy Commission in 1991. Each of these outside experts were active, key collaborators in the development and implementation of the SMUD Solar Program and a key to its success.

8. Policy and its Impact on Market Development

The market creation potential of SODC should not be underestimated. Through its transformational initiatives, SMUD became the leader in utility grid-connected applications of PV with the world's largest, single utility, distributed PV power system. By 2002, nearly 10 MW of PV systems were installed in Sacramento distributed over some 1000 installations. These installations included residential rooftops, commercial buildings, parking lots, and substation power plants. While very small by today's standards, this 10 MW represented over half of the grid-connected PV in the US at the time and led directly to the California Emerging Renewables PV Program. Today, due to the success of the statewide program, California has over 12 GW of grid-connected PV.

The goal of a transformational energy policy should be to demonstrate the value and importance of a long-term commitment that assures solar energy will grow in the utility's district along a sustainable and assured path. As SMUD first demonstrated, this led to a reduction in the cost of solar for the utility and the industry, with a resulting reduction in costs for the installers and buyers. A real world market was established for all to see.

However it became clear that if the industry and the market were to grow only within the confines of a few individual utilities, it would not generate the scale or scope for an ultimate national conversion to clean energy. A new policy instrument was needed based on government mandate that included long-term goals (20+ years) and encapsulated widespread areas. One such policy instrument that is based on SODC is the Renewable Portfolio Standard (RPS), which was first introduced in 1995 by one of the authors of this paper (DWA).

In complying with the RPS rules for their territories, individual utilities are following many of the program particulars set forth by SMUD and its use of SODC. As a result, the growth of solar and other renewables (both distributed generation and utility scale generation) has now risen to unimaginable global scope when compared to the 1990's. SODC has proven a viable policy to go beyond the results of standard diffusion models and accelerate commercialization much as seed crystals can accelerate a crystallization process.

The SMUD PV Pioneer Program was the first commercialization effort for grid-connected PV in the US and showed there was a real market there with no technical problems preventing it. It showed the power of SODC. The SMUD Solar Program set the stage for acceptance by other utilities (perhaps grudgingly) and regulators of distributed generation. Through its efforts, SMUD jump-started the California and national solar electric (PV) grid connected marketplaces through its PV Pioneer Program and broad but strategic commercialization efforts based on SODC. What SMUD did was the model for and directly led to the California Solar Initiative program that created a booming market. That set off the explosive growth of the PV market in California and thus in the US. This series of successful efforts and developing markets played a key role in the Paris Worldwide Climate Change Agreement. It also showed that what one does in one's community can indeed help to change the world!

So SODC is not an obsolete policy, nor are the lessons learned at SMUD. SMUD, in many ways, kicked-started the solar energy revolution in the United States, and demonstrated the techniques others can follow.

9. A Roadmap for Utilities in Transition

Utilities today are faced with substantial challenges to their century-old business model and are looking for new ways to adapt. Based on the lessons learned at SMUD, a utility might consider investigating new, distributed technologies with significant potential to serve target customers who have a compelling reason to buy, given there is the ability to assemble a whole product that meets that compelling need. The utility would also need to leverage their natural advantages in distribution and program financing, as well as use their position as a familiar supplier to make their program more acceptable to the target audience.

Many utilities have limited options to meet increasing demand for electric power: energy efficiency (consume less power), build expensive new generating facilities, or embrace clean energy through renewable sources. In addition, intermittency and peak load shifting (leading to so-called "duck curves") raise additional challenges with increasing penetration levels.

During the first half of 2016, several utilities have launched pilot programs that integrate rooftop solar with dispatchable, distributed electrical storage (DDES), creating what is known as a "virtual power plant." The goal of a virtual power plant is to transform distributed renewables into a single source of electricity and smooth out peaks and steep ramps in generation. These "grid assets" provide the added benefit of supplying backup power, while making a grid more flexible and reliable.

In many ways, DDES is in much the same market state that distributed solar was in the early 1990s. There are a few manufacturers, a number of early demonstration projects, no real or viable market, and tremendous but unfulfilled promise.

Using the technology adoption lifecycle as a roadmap, a utility wanting to encourage the adoption of DDES and virtual-power-plant technology must determine the customer's compelling reason to buy, recruit the necessary partners and allies, and assemble a whole product or package to meet the customer's need.

Through its whole product approach, SMUD made it "easy to go solar" by taking the risk out of the purchase decision -- while making everything easy to understand, to permit, and to interconnect. This included simplifying and standardizing the solar array, the intertie equipment, streamlining the interconnection process, and providing non-stop educational initiatives. This exact model would need to be followed and implemented for a virtual power plant program to be successful.

The challenge presented with the recently announced closure of the PG&E Diablo Canyon Nuclear Plant and the planned replacement of that capacity with a combination of solar, wind, electric storage, and energy efficiency presents an ideal opportunity to apply transformational programs to encourage and commercialize the application of virtual power plants. The Diablo closure presents much the same challenge as well as opportunity as the Rancho Seco closure decades earlier. The frameworks presented in this paper can be used to accelerate the commercialization of DDES power resources, which offer the most effective way to successfully

respond to this challenge.

Key stakeholders – state and local governments, the utility, equipment suppliers, other regional utilities – might implement a technology commercialization program specifically aimed at reducing the cost of distributed electric storage and associated controls while increasing its market acceptance. The combination of the SODC process with the whole product approach to mainstream adoption would lower risk, develop a sustainable market, and offer a cost effective way to respond to the Diablo closure.

The goal of every energy provider today should be to implement creative solutions that ensure customer choice while contributing to grid efficiency, reliability, resilience and security. And utilities will need to accept the realities of mainstream technology adoption for many of their transitional programs to succeed.

10. The Seven Deadly Sins of Utility Transformation

To make a successful transition to a clean energy future based on renewables and distributed storage, utilities must avoid seven specific pitfalls and errors. The “seven deadly sins” to avoid are:

- ⊗ **Favoring specific technologies:** it is imperative for a utility to take an “application” approach when defining the technical core of a whole product or complete package. Market transformation initiatives are much more effective when applied to a specific application (such as rooftop, grid-connected PV) rather than one specific technology such as thin film PV for example. Maintain a broad technology focus!
- ⊗ **Competing with the private sector:** it is also imperative for a utility to avoid using its monopoly power to compete in established markets against the private sector. SODC is a transformational technique that requires planned changes to both incentives and the product delivery mechanism. The private sector must be nurtured and supported as it undertakes product delivery that was initially managed by the utility.
- ⊗ **Placing convenience over customer need:** the catalyst for driving adoption by mainstream customers is to understand the target customer’s compelling reason to buy, which may not match a utility’s idea of what is easy to implement. The preferences of the mainstream customer must out-rank the needs of the utility.
- ⊗ **Target customer confusion:** it can be tempting to observe the natural interest early customers have in a new technology and accidentally build your distributed energy resources based on the preferences of early adopters. Don’t target early adopters. The complete package needed to attract mainstream customers is radically different.
- ⊗ **Clinging to old relationships:** both SODC and mainstream technology adoption rely on two-way, mutually beneficial relationships with customers. The old philosophy of treating your customer as “a meter” in a one-way world of centralized generation will not fly. Customers are now partners.
- ⊗ **Process management fragmentation:** the effectiveness of a transformation program can be radically diluted when a utility uses process management teams in which different groups are responsible for different phases of the program. The SODC effort is most effective with a dedicated, knowledgeable, and committed Program Team with cradle to grave responsibility.
- ⊗ **Waiting for a commercial market to form:** time is not always on your side when making a transition to distributed/renewable energy and its new business model (see Rancho Seco example above). Sometimes the utility must actually create the commercial market needed to successfully re-invent itself. Use the powerful framework of SODC to create new markets if none exist.

11 A Word of Caution

When SMUD designed the PV Pioneer Program there was little or no data about solar-technology adoption upon which to base critical decisions. And solar market development over the past 30 years has been a venture into the unknown.

When experience-based data are not available, market development frameworks such as SODC and the technology adoption lifecycle are often the only choice because they predict what an outcome will be, even

though a specific situation is unprecedented.

The technology adoption lifecycle and the whole product concept were created to serve the needs and circumstances of commercial companies. And the objective function of a company is best expressed in terms of earnings before interest, taxes, depreciation and amortization (EBITDA). Mainstream technology marketing has a meaning in that context. However, an entity such as a university, a hospital or a public utility has an objective function that is very different from EBITDA and net margins.

Market development models are not universal truths. Models enable a discussion within organizations and provide organizations with a framework that encourages them to reflect on their strategy. All models and frameworks have weaknesses and incompatibilities. Reality is always more complex. Despite their potential shortcomings these models were proven at SMUD to be very useful.

12 References

- [1] Bohlen, J. M.; Beal, G. M. (1957), The Diffusion Process, Special Report No. 18 Agriculture Extension Service, Iowa State College 1: 56–77.
- [2] Rogers, E. M., (1962). Diffusion of Innovations, Glencoe: Free Press.
- [3] Levitt, T., (1980) Marketing Success Through the Differentiation of Anything. Harvard Business Review, January – February, p.83-91
- [4] McKenna, R. (1985) The Regis Touch: Million-Dollar Advice from America's Top Marketing Consultant, Addison-Wesley Publishing Company
- [5] James, L., (1992) The High-Tech Product Lifecycle. Software Association of Oregon Publications, volume 3, number 2
- [6] Moore, G. A. (1991) Crossing the Chasm: Marketing and Selling High-Tech Products to Mainstream Customers. Harper Business Essentials
- [7] Osborn, D.E., (2005) “Key Utility Contributions to the US Grid-Connected PV Market: The PG&E and SMUD Solar Experience”, ISES Solar World Congress.
- [8] Aitken, D.W., (1991) “Sustained Orderly Development”, Report for the California Energy Commission on behalf of the Center for Energy Efficiency and Renewable Energy (CEERT).
- [9] Osborn, D.E., (2000) “Sustained Orderly Development and Commercialization of Grid-Connected Photovoltaics: SMUD as a Case Example”, Advances in Solar Energy XIV, American Solar Energy Society.

High-Efficiency ZEB & Control Systems



Guidelines for Residential Sub Metering

Mary Hatch and Hazem Rashed-Ali

University of Texas, San Antonio (United States)

Abstract

This report outlines a protocol for the collection and analysis of residential sub metered data. It provides concise guidelines on current best practices for measurement, analysis, diagnostics, and documentation of residential end-uses. End-use monitoring offers interested parties the ability to make informed decisions by providing direct feedback for design decisions and occupant behavior.

The protocol outlines levels of objectives, what to measure, how to measure it, analysis guidelines, and best practice documentation methods. This protocol is a universally beneficial tool for all parties associated with the built environment including designers, builders, owners, building operators, city bodies, and policy makers. These guidelines are a tool to increase the likelihood of producing beneficial data in a sub metered project.

Keywords: Residential, energy monitoring, post occupancy evaluations, disaggregated energy, sub metered monitoring

1. Introduction

This paper offers concise guidelines for residential sub metering. It is intended for parties associated with the residential environment including designers, builders, owners, building operators, city bodies, and policy makers. As a diagnostic tool, the protocol can be used to reduce monthly energy use and cost, to identify maintenance concerns, and to measure retrofit opportunities. For policy makers, it enables informed conservation programs. For designers, it is a learning and feedback tool for design assumptions and modeled predictions.

Sub metering is a form of disaggregated electrical monitoring, referring to the ability to measure electrical consumption at the breaker level for specific end-uses. End-use consumption can be either directly measured or estimated. Although promising, no current estimation models are able to accurately replace sub metering as they do not meet the “90 rule” yet (90% accuracy, 90% of the time, for 90% of the circuits) (Fisher, personal communication, 2015). The vast majority of sub meter installations are currently for commercial projects. This practice is newly adapted to residential application with few existing guidelines. As such, this paper proposes a protocol specifically developed for residential collection and analysis of sub metered data based on relevant case studies and existing guidelines.

The protocol outlines what to measure, how to measure it, analysis, and best practice documentation. Scope of measurement includes energy use, energy cost, gas, water, and independent variables, such as climate, occupancy habits, etc. Guidelines for measurement include sensor types, data storage and transmission, scanning and logging intervals, collection spans, and verification and calibration. Analysis guidelines include accuracy and normalizing, missing data, and metric selection and comparison. An overview of best practice documentation methods is also included.

2. What to Measure

Goals should be clearly identified at the start of each project to define the level of collection and analysis required (Singh, 2011). For example, a project could seek a detailed understanding of how the building is functioning, or a general overview of the largest end use consumers. The levels of variables and analysis should be tailored to the level of depth required for the goals of the project. As with all systems, creating as simple of a system as effectively possible can greatly aid in producing helpful results.

2.1 What to Measure: Energy Use

The common measurement for energy use is recorded in kWh. Additional measurements of electricity can be recorded if the specific goals of the project necessitate, including voltage and amps (U.S. EIA, 2015).

2.1.1 Whole Electric Consumption

Monitoring whole-house electrical consumption is always recommended (Chasar & Withers, 2012; Sherwin et al., 2010; Wahlstrom & Harsman, 2015). Whole-house use can be measured by monitoring the main meter. If more than one meter exists, the sum of the meters may be referred to as the main meter (ASHRAE, 2002).

2.1.2 Utility Totals

Utility totals can provide additional verification for the accuracy of onsite measurements. Historical utility bills may provide a comparison to current energy usage. Generally, 12 to 24 months of historical data is recommended (ASHRAE, 2002; Chasar & Withers, 2012; U.S. EIA, 2015). The majority of electrical utility companies do not collect interval data on residential usage and are only able to provide total monthly consumption (U.S. EIA, 2011). Some utilities are able to provide daily or hourly totals of consumption.

2.1.3 Disaggregated Electric Consumption

The level of end use monitoring should develop from the objectives of the project. All end use disaggregated electricity should be time-stamped (U.S. EIA, 2015).

2.1.3.1 Measuring Dominant Loads

Dominant residential end uses have been traditionally grouped into four categories – heating, air conditioning, water heating, and plug loads consisting of appliances, electronics, and lighting. As dominant loads are installed on individual breakers, each dominant load can be identified and monitored independently. For this level of analysis, specific appliance and plug loads are not separately measured (Sherwin et al., 2010). Any additional dominant loads should also be addressed, including but not limited to, electric vehicle charging stations, solar panel production, solar hot water production, and swimming pools.

2.1.3.2 Sub Metering Specific Loads

Systems with multiple components can be sub metered for a detailed understanding of performance (Estes & Santoso, 2015). If in an environment dominated by heating and/or cooling concerns, it is often recommended to sub meter the HVAC system into comprising components to monitor the performance of each component, such as the air handlers, condensers, or heat pumps (Chasar & vonSchramm, 2012; Chasar & Withers, 2012; Sherwin et al., 2010). Further, if the residence utilizes a less conventional system, such as solar hot water heating, detailed sub metering of each component is recommended to ensure the correct installation and calibration.

2.1.3.3 Comprehensive Sub Metering

Comprehensive sub metering includes dominant loads and the detailing of specific plug, appliance, and lighting loads. This level of sub metering is to understand the detailed performance of the house as a whole system. In general, this level of sub metering includes lighting, receptacles, individual appliances, and house systems including garage door openers, security systems, etc (Christian et al., 2010; Stawitz et al., 2008). While appliances and some lighting systems are installed individually on breakers, most lighting and plug loads will be indistinguishable. If necessary for this level of analysis, monitors may be added to individual receptacles and labeled for use to determine accurate loads individual to lighting and plug loads.

2.2 What to Measure: Energy Cost

As most projects are driven by cost comparative and savings initiatives, recording actual monthly residential

rates at the time of measurements enables accurate costs to be associated with consumption (Christian et al., 2010). Cost could be measured as total cost per day for whole-house consumption, or for specific end use consumption to understand the cost of individual house systems (U.S. EIA, 2015).

2.4 What to Measure: Gas & Water

If outlined by the goals and objectives of the project, additional house consumptions, including gas and water, can be measured on site (Chasar & vonSchramm, 2012; Christian et al., 2010; Stawitz et al., 2008; U.S. EIA, 2015). Although outside of the scope of this set of guidelines, the identification of a level of detail complimentary to the energy analysis is recommended.

2.5 What to Measure: Independent Variables

Independent variables for residential sub metering are defined as factors that affect the energy use of a building but cannot be controlled. These variables most commonly consist of climate, occupancy, and household demographics (ASHRAE, 2002; U.S. EIA, 2011).

2.5.1 Climate

Common conditions collected include temperature and relative humidity, with solar radiation and carbon dioxide levels collected as necessitated by the project (Chasar & vonSchramm, 2012; Chasar & Withers, 2012; Kansara et al., 2011; Parker & Sherwin, 2012; Sherwin et al., 2010; Stawitz et al., 2008). Climate measurements are collected as an additional verification of performance. Interior conditions can be used to test the performance of HVAC systems and to measure indoor air quality. Exterior conditions can be used to provide accurate measurements of exterior climactic conditions, both for use as efficiency performance verification and to normalize for extreme weather conditions.

2.5.2 Occupancy Habits

Occupant habits can have a substantial impact on the consumption of residential end uses. Although currently relatively unusual, basic occupant surveys can be beneficial to understand variations of end use consumption from standard benchmarks. Simple occupant answers regarding thermostat settings, usage habits, and satisfaction rates may be beneficial in identifying reduction strategies (Edwards et al., 2012; Stawitz et al., 2008). Additional information may be beneficial specific to project end goals. For example, if an electrical car is included in analysis, information regarding work schedules and mileage driven should be collected.

2.5.3 Demographics

Simple demographics are necessary to understand household consumption. The number of residents and the type of occupancy (primary residence, vacation house, etc.) are required to calculate basic metrics. For further analysis and educational objectives, additional characteristics can be surveyed including the age of residents, the status of residents (single, married, etc.), the disposable income, and information regarding head of household (U.S. EIA, 2015).

2.5.4 Household Attributes

The most basic level of residential analysis requires noting the conditioned floor area and the type of energy systems used for heating and cooling. For most levels of analysis, attributes to record include the above plus the type of housing (detached, semi-detached, etc.), the year constructed, the number of floors, any electrical production on site, and any pools included in the analysis. For detailed energy audits, collect information regarding façade elements, window types, roof, wall construction, and other home details affecting energy consumption (Wahlstrom & Harsman, 2015).

3. How to Measure

Exploration of an appropriate combination of sensor types can provide accurate data detailed at the necessary level. An appropriately sized sampling method can answer project questions while minimizing costs associate with analysis (ASHRAE, 2002).

3.1 How to Measure: Sensor Types

3.1.1 Circuit Level & Whole House Meters

Multiple circuit and whole house meters are available for market purchase, including whole-house Building Management Systems for integrated and detailed feedback, mid-level energy monitoring systems suitable for most projects, and small-scale systems such as a 5-appliance load system (Kansara et al., 2011; Levasseur et al., 2012). Common metering systems utilize volt and amp measurements for resistant loads, currently the most common loads found in residential applications. However, if the project goals necessitate great detail and accuracy, a system utilizing measurement with true rms wattmeters is suggested in order to provide increased measurement accuracy for equipment with reactive loads, such as fluorescent lighting and motors (Efficiency Valuation Organization, 2012).

3.1.2 Outlet Sensors

If the project goals require a more comprehensive level of monitoring than available to circuit based monitoring, outlet sensors are able to provide a more detailed understanding of residential consumption (Levasseur et al., 2012). Outlet wall monitors can be used in conjunction with circuit level and whole house monitoring systems to provide measurement of specific appliances (Ozturk et al., 2012; U.S. EIA, 2015). Outlet sensors enable the measurement of specific residential uses, such as plug-based lighting, televisions, and window-unit air conditioners, usually indistinguishable in circuit level monitoring.

3.1.3 Runtime Sensors

For some residential electrical usage, a runtime sensor may suffice in providing an estimate of overall usage. For example, certain lighting and motors can be measured by runtime to provide a usage estimate and an understanding of usage patterns. Dependant on the goals of the project, runtime sensors may offer a more affordable and easily installed alternative to circuit level systems (ASHRAE, 2002).

3.2 How to Measure: Data Storage & Transmission

The majority of electrical monitors use a wireless network system to transfer collected data to a storage server (Levasseur et al., 2012). Data storage capacity can vary and should be approximated to fit the logging intervals and collection span of the project. Data services are generally free to low cost. For ease of collection, data is recommended to be available online to authorized users only. Consent of the residents and owner is necessary. The majority of systems allow for data collection by downloading from web interfaces (U.S. EIA, 2015). As data transmission and storage can be dependant on existing household internet, a review of internet reliability prior to system installation may provide an increased project performance at a low cost.

3.3 How to Measure: Scanning & Logging Intervals

3.3.1 Scan Rate

Common energy monitoring systems scan data either continuously or in 10-second intervals (Christian et al., 2010; Efficiency Valuation Organization, 2012; Levasseur et al., 2012; Sherwin et al., 2010). Continuous scanners offer real-time system feedback to allow for immediate problem detection or instant behavioral feedback (Stawitz et al., 2008). In the majority of projects, 10-second scanning is effective.

3.3.2 Logging Intervals

Logging intervals should be selected to fit specific project questions and goals. Appropriately sized logging intervals allow for efficient and timely data analysis while providing useful project information. Monthly integration is recommended for all projects. Data can be reported at intervals of daily, hourly, 15 minute, 1 minute, and 15 second intervals.

Two to three logging intervals are recommended. The first, if needed for project goals, is to log intervals mirroring the electric-demand measurement method of the electric utility to allow for comparable peak-demand profiles (Efficiency Valuation Organization, 2012). The second logging interval should be at the level identified as the primary level of analysis for the project. Thirdly, one order of magnitude more detailed than intended baseline analysis is recommended to allow for deeper exploration if problem solving occurs.

Monthly collection of data can be used to answer systems seasonal efficiency questions, weather-related consumption, and broad overviews of performance. Daily data collection allows for an overview of behavior-

based residential consumption and the location of peak-day consumption. Hourly collection of data represents the typical utility sampling rate of advanced metering infrastructures and correlates well with commonly collected hourly weather data as well as designed engineering load profiles (U.S. EIA, 2015). Hourly data allows for the most appropriate understanding of power factors and daily peak load profiles and peak pricing events (Christian et al., 2010; Fisher, personal communication, 2015). For the majority of projects, this level of data is sufficient without overwhelming the file size (U.S. EIA, 2015).

Fifteen-minute logging intervals are appropriate for detailed analysis of the performance of specific systems in question (Christian et al., 2010; Parker & Sherwin, 2012). Some residential modeling applications, including machine learning algorithms, benefit from this level of sampling (Edwards et al., 2012). One minute and fifteen-second level data logging is generally used to capture the most detailed level of analysis available for residential consumption modeling. With this level of granularity, specific system diagnosis is available including identifying air conditioner short-cycling and detailed understanding of electric vehicle use (Fisher, personal communication, 2015).

3.4 How to Measure: Collection Span

The duration of the measurement should span the full range of independent variables, including weather patterns, occupancy schedules, and all operating modes from minimum to maximum in order to provide an intended level of certainty (ASHRAE, 2002; Efficiency Valuation Organization, 2012). As whole building energy use can be significantly affected by weather conditions, generally a whole year of measurement is recommended (Efficiency Valuation Organization, 2012). Two years of monitoring data can provide seasonal and residential variation (Kansara et al., 2011). If extensive analysis is required, up to four years of data can account for weather and occupancy variations. For the most holistic and continuous understanding of the performance of a residence, continuous monitoring and yearly analysis can provide feedback for alterations in housing characteristics and occupant habits (U.S. EIA, 2015).

For some projects, yearlong monitoring may be out of the scope and budget of the project. Normally, a full year of energy use and weather data are required to determine actual energy use. For short term monitoring, it is recommended to determine the best time and duration based on the ambient temperature of the location, and the closeness of the dataset's mean temperature to the annual average. Research has shown that an average of three to four months of monitored data is adequate to estimate an approximate annual building energy use if monitored at the appropriate time, and if the data set is able to capture seasonal and daily variations (Singh, 2011).

3.5 How to Measure: Verification & Calibration

Verification and calibration of equipment is a vital step often forgotten for time or budgetary constraints. To ensure the proper function and intended accuracy of measurement, equipment should be verified as functioning properly and monitored to resolve unexpected occurrences in order to allow for the best possible data set for the given monitoring period (ASHRAE, 2002). Equipment can be verified through a four-step operation approach. Firstly, a visual inspect can serve to verify the proper installation of equipment. Secondly, sample spot measurements of key systems can provide immediate feedback for the current accuracy of the equipment. Thirdly, a short-term performance testing period can ensure proper performance as a system before long spans of time are invested into the project. Fourthly, data trending and review can provide approximate measurements of accuracy and general guidelines appropriate to relevant benchmarks in order to quickly calibrate installed systems (Efficiency Valuation Organization, 2012). For long-term monitoring, equipment should be routinely recalibrated at critical measurement points. A minimum of sixth month recalibration is recommended to calibrate instruments, measure system accuracy, and provide data validation (ASHRAE, 2002). If the project relies on a high level of detail and accuracy, to ensure less data loss, redundant sensors and frequent on-line checks are recommended to reduce the impact of sensor failure.

4. Analysis

4.1 Analysis: Accuracy & Normalizing

No data set is without error. Errors are identified through data validation by comparing the collected data to

internal or external benchmarks (ASHRAE, 2002). If the project entails whole house monitoring, an internal benchmark would be the sum of the sub metered systems compared to the total electrical consumption measured at the main meter. For an external benchmark, the sum of the system can be compared to the power bill (Stawitz et al., 2008).

Typical accuracy found in commercial projects range from <1%, to average values of <4%. The greatest range in the values found in the reviewed case studies found a percent error of just under 10% (Efficiency Valuation Organization, 2012; Stawitz et al., 2008). Data outside the desired level of accuracy or project norms may be omitted, adjusted through calibration, interpolated from preceding and following data, adjusted to an average value, or ignored (ASHRAE, 2002).

Data can be normalized for independent variables, including weather and occupancy. Normalization for weather is recommended if comparing to predicted energy use and heating or cooling degree days differ significantly from the weather data set used to generate the prediction (Christian et al., 2010). If needed, data can be normalized using linear regressions, including least squares and best-fit linear regressions (Chasar & Withers, 2012). Accuracy and normalizing should be reported with the final level of analysis.

4.2 Analysis: Missing Data

Generally, missing data can be handled by omission, or by substituting replacement data from interpolated or calculated values. However, this is only recommended for small omissions. Large gaps in data are difficult to restore with accuracy (ASHRAE, 2002). From the reviewed case studies, an average of 0.01% to 0.66% of data was reported missing from collections spans 92 days to one year long (Chasar & vonSchramm, 2012; Stawitz et al., 2008). Missing data removed from the analysis should be noted within the final report.

4.3 Analysis: Metrics

4.3.1 Load Factors & Peak Times

A load factor, or power factor, is the ratio of average over peak consumption (Christian et al., 2010). Load factors can be calculated for peak days out of a month, or for peak hours within a single day (Singh, 2011). For the most basic of projects, peak electric consumption can be noted for the winter and summer season. For the majority of projects, the largest consuming day of each month of data available should be noted (ASHRAE, 2002; Christian et al., 2010). This enables an understanding of loads associated with seasonal variation. For projects concerned with detailed analysis of specific systems or whole house electrical supply and demand, the peak hour of each day can be recorded (Fig. 1). Recording and understanding load demand during peak times enables the strategic application of efforts to reduce critical peak pricing events.

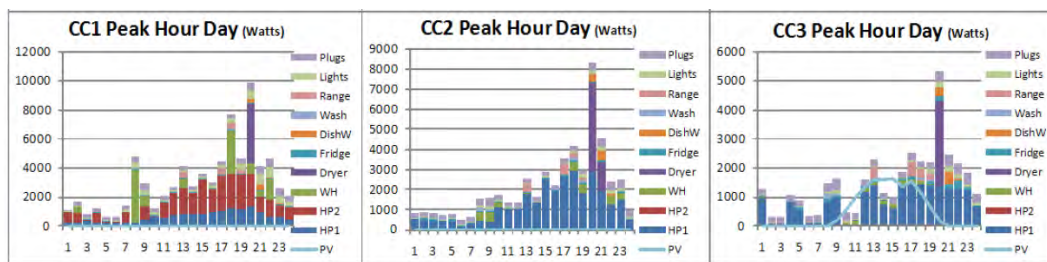

Fig. 1: Comparison of peak days (Christian et al., 2010)

4.3.2 Energy Per Person

Although a less common metric, calculating the energy per occupant may allow for a more direct representation of individual habits on residential consumption. Occupancy habits must be accounted for in order to provide a basis for comparison. For the most accurate comparison, and to account for seasonal changes, the energy per person should be calculated for an entire year. If consistent data is unavailable, the energy per person may be calculated and compared per month (Sherwin et al., 2010).

4.3.3 Energy By Size

Energy by size, known as the Energy Usage Intensity (EUI), is the most common metric for comparison. The

energy consumption is calculated for the amount of conditioned space within the building (Sherwin et al., 2010). A complete year of data is needed for the calculation of a true EUI to allow for seasonal variation. For an approximate comparison to yearly benchmarks, if a full year of consistent data is not available, extrapolation or modeling is required to supplement the data. If a full year of data is unavailable, the EUI may be calculated and compared per month.

4.3.4 Energy Cost

An Energy Cost Index (ECI) can be calculated by dividing the net annual energy cost by the gross floor area to provide a metric for comparison (Singh, 2011). For a retrofit project, as savings cannot be directly measured, the savings of a project can be determined by comparing the pre and post energy costs of a project, compensating for any appropriate adjustments for a comparable time period (Efficiency Valuation Organization, 2012). If multiple comparable homes are included in the project, direct monthly energy costs can be compared to demonstrate for costs associated with various levels of construction or occupant habits (Christian et al., 2010).

4.3.5 Whole Building Consumption

Total site consumption can be calculated by the year, the month, the day, and the hour, depending on the needs of the project. For example, multiple homes compared in the same region will benefit from yearly and monthly comparisons (Christian et al., 2010; Sherwin et al., 2010; Singh, 2011). For a detailed understanding of the performance of a home, total and average hourly consumption can be charted throughout an average daily usage profile to provide a visualization of the performance over the course of a day (Fig. 2) (Christian et al., 2010; Stawitz et al., 2008).

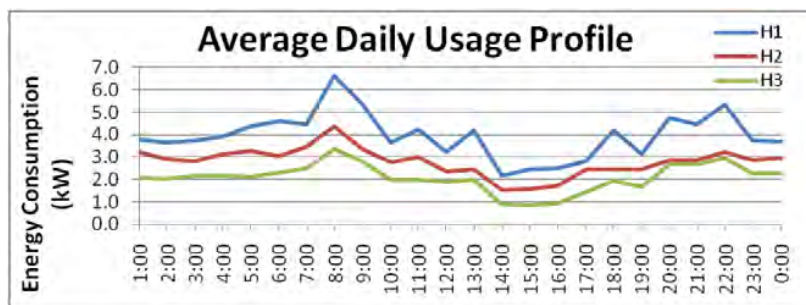

Fig. 2: Average daily usage profiles for February 2010 (Christian et al., 2010)

4.3.6 Major End Uses

The most common analysis of disaggregated whole building consumption is in the form of calculating and visually representing major end uses. End uses can be represented as a percentage of the total consumption to provide an understanding of a single building or in the form of kWh to provide comparison to other buildings within the same project. The most common form of end use comparison is by breaking the major end uses into four general categories: air conditioning, water heating, space heating, and appliances, electronics and lighting. Additional major systems, including pools, should be included. If a more detailed analysis of the project is fit, end uses can be broken further to represent specific appliances or house systems (Christian et al., 2010). If a detailed analysis of one system is performed, each component of the system should be represented. For a holistic understanding of building performance, it is important to indicate if any systems rely on additional forms of energy, including as natural gas, for end uses such as space heating, water heating, cooking, etc. (U.S. EIA, 2013).

4.3.7 Energy Production

If energy production is available, the energy production should be calculated and graphed to track system costs and savings, compare to whole house consumption, and plot for production for time of day (Christian et al., 2010).

4.4 Analysis: Comparison

4.4.1 Compare Uses

A visual representation can provide an aid in understanding how each system in the home consumes in comparison to other systems (Fig. 3). If individual systems within an end use are analyzed for performance, such as the components of an HVAC system, it is recommended to display the performance of the components of the systems as percentages of the whole system, as well as in a visual representation of the entire consumption of the home (Stawitz et al., 2008).

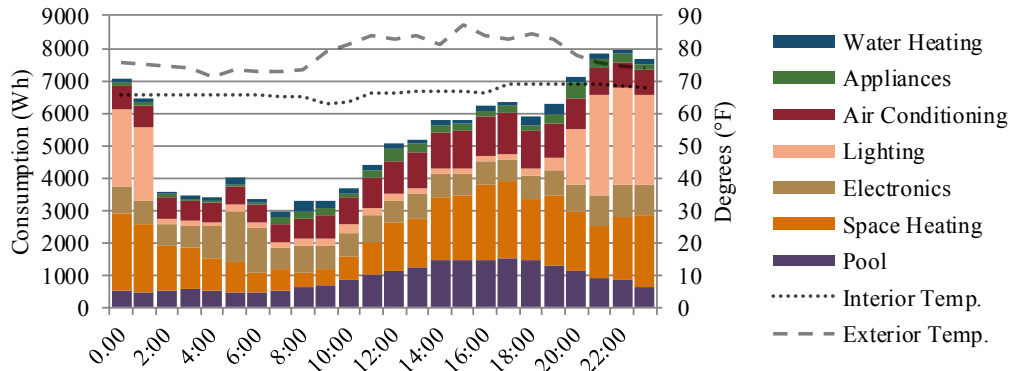

Fig. 3: Hourly average from June 2015 for Case Study A (Hatch & Rashed-Ali, 2016)

4.4.2 Comparable Homes

A common set of conditions, including behavior patterns, must be selected to allow for the comparison of similar studies or homes (Edwards et al., 2012). Whole house systems and major systems in each house can be compared for performance. If one residence has efficient systems installed and other variables are the same or similar, these systems can be compared to establish an annual energy savings for each major energy user (Fig. 4). The comparison in cost and energy consumption can be broken down from yearly, to monthly, to daily (Christian et al., 2010).

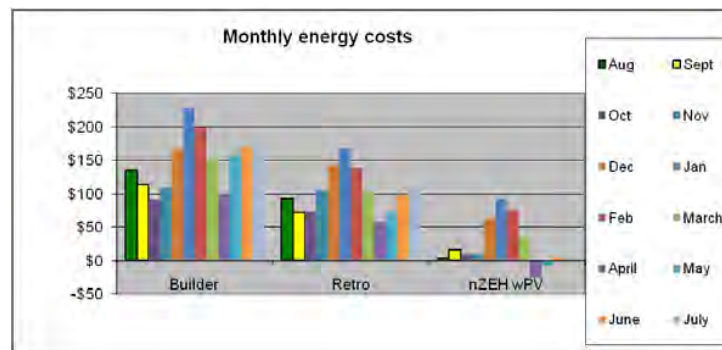

Fig. 4: Monthly energy cost for each house, August 2009-July 2010 (Christian et al., 2010)

4.4.3 Pre and Post Retrofit Comparison

Pre and post-retrofit monitoring and analysis allows for measured energy savings for whole house consumption as well as individual end uses (Chasar & Withers, 2012; Christian et al., 2010). Stable behavioral patterns must be determined to allow for comparable consumption from pre and post-retrofit analysis (Edwards et al., 2012).

4.4.4 Compare to Simulated Predictions

Actual monitored consumption values can be compared with end use and whole building predicted consumption (Christian et al., 2010; Stawitz et al., 2008). These values can be compared and adjusted to identify the source of discrepancies within the prototype computer simulations (Sherwin et al., 2010). If only a short data set is available, hybrid inverse modeling has been explored as a modeling method to predict energy use for the year by combining the short data set with a year of utility bills (Singh, 2011). Regression models may also be applied to uncover any statistical correlations on household consumption to building

characteristics or occupant behavior (ASHRAE, 2002; U.S. EIA, 2011, 2015).

4.4.5 Compare to Benchmarks

The purpose of the benchmarks is to provide a comparison of energy measurement with a base case or a standard (Meir et al., 2009). Comparison to a benchmark enables a percent savings relative to the benchmark and well as comparison to regional and national averages (Sherwin et al., 2010).

4.6 Analysis: Residential Benchmarks

Residential benchmarks fall into three general categories based on how the benchmark is determined. The first category of benchmark is created by an educated estimate of dominant end uses based on occupant surveys. The most prominent is the Residential Energy Consumption Survey provided by the U.S. Energy Information Administration. Although an approximation, estimated uses are available for each state in the U.S. and offer a great starting point for understanding expected performance (Fig. 5).

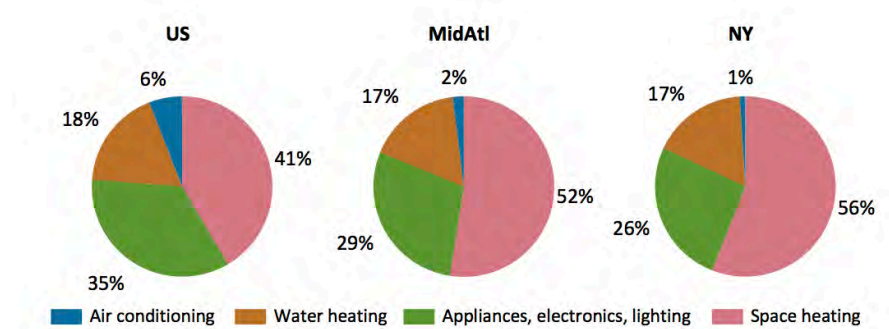

Fig. 5: New York RECS 2009 (U.S. EIA, 2009)

The second category of benchmark is developed by using recorded end use data from comparable residences. Although finding specific projects appropriately comparable can be difficult, measured data from specific regions provide a more accurate estimate for comparison. Pecan Street's Dataport is currently the largest source of disaggregated customer energy data. It provides raw data, visualizations, and reports for energy and water consumption based in Austin, Texas, narrowed by home characteristics.

The third category of benchmarking is a benchmark developed specifically for an individual project through predictive software modeling. Software modeling can take extra time, but is an alternative to provide contextually specific estimates if comparable homes are not available. To track progress towards whole-house energy savings goals, the Building America Research Benchmark represents mid-1990's standard construction as a fixed point in time to provide a set comparison of energy (Hendron & Engebrecht, 2010).

4.7 Analysis: Anomalies/Improvements

Once common metrics have been created and results have been compared to benchmarks, anomalies and improvements can be investigated in the project. Anomalies and improvements should be identified by the largest deviation from comparable benchmarks and projects. The more regional and comparable the benchmark, the more comparisons will enable insightful and diagnostic analysis for areas of improvement. The data should be examined for anomalies from the largest scale to the most specific scale necessitated.

5. Documentation

Documentation of a project allows for timely analysis and increased accuracy in achieving project goals. Documentation recommendations have been divided into three phases naturally corresponding to the progression of any project.

5.1 Phase I: Goals, Scope, & Intent

A specific set of goals for a project allows for targeted implementation of resources within project limitations, such as the time available, the accuracy necessary, and the budget available (ASHRAE, 2002; Efficiency

Valuation Organization, 2012). These goals, as well as the limitations, should be developed and documented at the start of the project. Through documentation, the method appropriate for obtaining the required information will become apparent. Alternative methods should be identified if high levels of accuracy are required. As time is often the most restricted commodity, a minimum level of performance should be outlined to dictate if and when systems require unplanned maintenance or replacement. The method and rigor of systems, scheduled calibrations, and responsibilities should be outlined and agreed upon (ASHRAE, 2002).

5.2 Phase II: Measurement & Documentation

Phase II begins with the installation and documentation of measurement equipment. Baseline conditions should be recorded, including the condition of the residence and major systems. A description of the measurement system should be included, along with a description of the installation method, location, and system installer (ASHRAE, 2002; Efficiency Valuation Organization, 2012). The monitoring schedule and associated responsibilities should be documented as performed, including predicted maintenance and data management, as well as unexpected repairs (ASHRAE, 2002; Efficiency Valuation Organization, 2012). This enables a timeline of system performance and repair to be compared with later analysis. Once data is pulled and analysis begins, the complete reporting period should be noted (ASHRAE, 2002).

5.3 Phase III: Method of Analysis

Analysis procedure should be documented to detail exactly how the analysis was performed, what assumptions were present, and what variables were considered (Efficiency Valuation Organization, 2012). Identified criteria, developed methodologies, and calculation steps should be recorded (ASHRAE, 2002). Any adjustments or omissions to the data set are to be noted, as well the determination of actual levels of accuracy (Christian et al., 2010; Efficiency Valuation Organization, 2012). All final comparisons and suggestions are best represented graphically.

6. Conclusion

This protocol is a universally beneficial tool for designers, builders, owners, building operators, city bodies, and policy makers. Benefits of collection include a detailed, in-depth understanding of the operations of a building, or a general overview of the largest end-use consumers. As a diagnostic tool, the protocol can be used to reduce monthly energy use and associated costs, to identify maintenance concerns, and to measure retrofit opportunities. For policy makers, it enables informed conservation programs and utility electrical production. For designers, it is a learning and feedback tool for design assumptions and modeled predictions. This protocol can be utilized by any of the outlined parties to assist in implementing a sub metering project by outlining development steps to increase the likelihood of producing beneficial data.

7. References

- American Society of Heating, Refrigerating and Air-Conditioning Engineers, Inc. (2002). ASHRAE Guidelines 14: Measurement of Energy and Demand Savings. Atlanta, GA.
- Chasar, D. & vonSchramm, V. (2012) Measured Performance of Occupied, Side-by-Side, South Texas Homes. Building America Partnership for Improved Residential Construction.
- Chasar, D. & Withers, C. (2012) Measured Cooling Performance and Potential for Buried Duct Condensation in a 1991 Central Florida Retrofit Home. Building Technologies Program. U.S. Department of Energy.
- Christian, J., Gehl, T., Boudreaux, P., New, J., Dockery, R. (2010). Tennessee Valley Authority's Campbell Creek Energy Efficient Homes Project: 2010 First Year Performance Report July 1, 2009–August 31, 2010. Oak Ridge National Laboratory.
- Edwards, R. E., New, J., & Parker, L. E. (2012). Predicting future hourly residential electrical consumption: A machine learning case study. *Energy and Buildings*, 49, 591 – 603.
- Efficiency Valuation Organization. (2012). International Performance Measurement and Verification Protocol: Concepts and Options for Determining Energy and Water Savings Volume 1.

Mary Hatch / ASES National Solar Conference Proceedings (SOLAR 2016)

- Estes, H. & Santoso, S. (2015). Analysis of High-Resolution Electric Vehicle Charging on Time-of-Use Grid Demands. IEEE PES General Meeting Conference, Denver, CO.
- Hatch, M. & Rashed-Ali, H. (2016). Residential Energy Monitoring: A Case Study of Four Sub Metered Homes. Eco-Architecture 2016. Wessex Institute of Technology.
- Hendron, R., & Engebrecht, C. (2010). Building America House Simulation Protocols. National Renewable Energy Laboratory.
- Kansara, T., Ridley, I., & Reynolds, R. (2011). Post Occupancy Evaluations of buildings in a Zero Carbon City. GCREEDER, April 26th – 28th, 2011.
- Levasseur, M. A., Jomphe, S., Sicard, D., Dulipovici, A., Gagnon, F., & Gagnon, G. (2012). A Wireless Sensor Network for Residential Electrical Energy Consumption Measurement. 25th IEEE Canadian Conference on Electrical and Computer Engineering.
- Meir, I. A., Garb, Y., Jiao, D., & Cicelsky, A. (2009). Post-Occupancy Evaluation: An Inevitable Step Toward Sustainability. *Advances in Building Energy Research*, 3(1), 189 – 219.
- Ozturk, Z., Arayici, Y., & Coates, P. (2012). Post Occupancy Evaluation (POE) in Residential Buildings Utilizing BIM and Sensing Devices: Salford Energy House Example. School of the Built Environment, University of Salford, United Kingdom.
- Parker, D. & Sherwin, J. (2012) Achieving Very High Efficiency and Net Zero Energy in an Existing Home in a Hot-Humid Climate: Long-Term Utility and Monitoring Data. Building Technologies Program. U.S. Department of Energy.
- Sherwin, J., Colon, C., Parker, D., Martin, E. (2010). Performance of Four Near Zero Energy Homes: Lessons Learned. Florida Solar Energy Center.
- Singh, V. (2011). Analysis Methods for Post Occupancy Evaluation of Energy-Use in High Performance Buildings Using Short-Term Monitoring. A Thesis for the Degree Master of Science at Arizona State University.
- Stawitz, C. C., McGehee, H. S., Devlin, C. M., Tan, F., & Wong, S. (2008). Increasing Awareness of Residential Energy Consumption: Data Analysis and Presentation for ecoMOD, a Sustainable Housing Initiative. IEEE Systems and Information Engineering Design Symposium, University of Virginia, 55 - 59.
- U.S. Energy Information Administration (2009). Household Energy Use in Texas: A closer look at residential energy consumption. Washington, DC: U.S. Department of Energy.
- U.S. Energy Information Administration. (2011). Residential Energy Consumption Survey: How does EIA estimate energy consumption and end uses in U.S. homes? Washington, DC: U.S. Department of Energy.
- U.S. Energy Information Administration. (2013, March 7). Heating and cooling no longer majority of U.S. home energy use. Washington, DC: U.S. Department of Energy. Retrieved October 10, 2015, from <https://www.eia.gov/todayinenergy/detail.cfm?id=10271>.
- U.S. Energy Information Administration. (2015). An Assessment of Interval Data and Their Potential Application to Residential Electricity End- Use Modeling. Washington, DC: U.S. Department of Energy.
- Wahlstrom, M. H. & Harsman, B. (2015). Residential energy consumption and conservation. *Energy and Buildings*, 102, 58 - 66.

INhouse

Professor Sandy Stannard and students Lisa-Marie Mueller, Alyssa Parr

[with input from Dr. Kim Shollenberger, Richard Beller]

California Polytechnic State University, San Luis Obispo (USA)

Abstract

This paper will describe the *process* and *product* of Cal Poly's U.S. Department of Energy's Solar Decathlon 2015 entry. The Solar Decathlon is a biennial competition in which teams of faculty and students work to design, build, and compete with solar powered residences. There are ten individual contests involved in the Decathlon, including measured as well as juried tasks. The team from Cal Poly [called "Solar Cal Poly"] included faculty and students predominantly from architecture and engineering but also included members from four colleges and over ten disciplines (involving over 100 students over the 2 year project). The hands-on nature of this design/build/operate competition offers faculty an opportunity to work in tandem with students in an attempt to put their ecological ideals (as they relate to the build environment) into action.

Keywords: *climatic responsive design, Solar Decathlon, design/build*

1. INhouse: An Idea

INhouse is a net-zero residence designed in response to the U.S. Department of Energy Solar Decathlon 2015 challenge, a home intelligently designed to respond to the conditions of the climate in coastal California, such that the majority of its needs for heating, cooling and lighting were addressed architecturally. The supplemental systems necessary for the remaining space conditioning, lighting, and power needs are efficient and effective. The public and private wings are serviced by an active core that contains the home's mechanical, electrical, plumbing, and monitoring systems. The private wing includes a master bedroom and a flexible space which may serve as a library, office, or secondary bedroom space. The public wing incorporates entertainment and dining spaces with thoughtful linkages to the exterior spaces and the views beyond.



Fig. 1: INhouse [east facade]

2. Climate and Place

The design of INhouse was driven by climate and place.

- **organize:** facing south with east/west elongation; designed around a “core” that houses the systems of the house, flanked by the passive “wings.”
- **insulate:** tight envelope with R 30.5 walls + roof; R 24 floor
- **shade:** shaded southern openings [utilizing bifacial solar panels that simultaneously shade, shape space, and generate power] and tuned envelope shading based on thermal mapping of incident solar radiation.
- **ventilate:** operable windows for cross and stack ventilation
- **stabilize:** use of phase change material to dampen temperature swings, applied both internally as well as decoratively (exposed so residents can view performance).
- **collect:** sun and water: net zero energy (solar power); water collection and grey water recycling.



Fig. 2: INhouse [north|south section]

3. Intuitive, Interactive, Integrated

INhouse is designed to inspire its residents to take control of their personal environment. Intuitive, interactive, integrated: the team’s interpretation of net-zero, a new way of interpreting a contemporary California home. INhouse explores the link between system and resident, with the goal of making operation and management intuitive, energy affordable, and waste minimal.

3.1 Intuitive

Through a precisely designed envelope and passive systems, INhouse is crafted to maximize the thermal and luminous comfort of its residents. Residents can easily learn how to operate the passive systems of the house - sliding screens, sliding glass walls, operable windows - in order to maintain their daily and seasonal comfort. Through a straightforward control system, residents can optimize their luminous and thermal comfort by communicating on site or remotely with the supplemental systems of the house, which include heating, cooling, and lighting systems. The operation of the INhouse systems does not require any rigorous training; the design of these systems is intended to be intuitive. By actively engaging with INhouse, residents can save energy, reduce costs and maximize comfort. Over time, residents will learn that small changes in their daily habits can result in a reliably comfortable living environment - one that not only elicits sensory delight but also realizes real energy efficiency.

3.2 Interactive

INhouse provides an environment that enables the resident to adjust the house to meet changing needs. Interaction with the house is based on the resident’s senses and aims at enhancing each experience. When the

weather is nice, s/he can open the folding glass wall between the living module and the outdoor solar bifacial room. When the sun is least harsh or views are too good to pass up, the resident can push open sliding screens along the southern edge of the bifacial room. By enjoying the bifacial room itself, the resident is directly interacting with one of the home's methods of energy production. Meanwhile, real-time feedback informs residents about energy use and production, allowing them to appropriately respond to this information. The interactive features of the home allow a fully customizable experience that can be tuned to the needs of the occupants.

3.3 Integrated

The home is designed around a core that contains its active intelligence - mechanical, electrical, plumbing, and monitoring systems. INhouse aims to unify all of the home's components into a coherent whole - from passive to active, indoor to outdoor, and architecture to engineering. All systems are integrated, creating an efficient home that is simultaneously delightful as well as user friendly. The resident dwells between the core and the wings, in open and comfortable spaces where thoughtful architectural design and mechanical systems meet.

4. Holistic Design

INhouse represents a collaborative team effort, a cohesion of architecture and engineering in which the sum of the parts result in a larger cohesive and delightful whole. The team's design combines materials and systems to create a modern California aesthetic.

4.1 Passive | Active

Designing INhouse to minimize environmental impact and maximize climate responsiveness and comfort begins at the most basic level - building shape and placement. The home's spaces are thoughtfully arranged with solar orientation in mind.

In a temperate climate such as San Luis Obispo, California, with near equilibrium between heating and cooling degree days, the design of INhouse utilizes these elements to achieve comfort balance. The team's climate analysis led to six primary climatic design priorities: organize, insulate, shade, ventilate, stabilize, collect. To organize, the house is elongated on its east-west access and the interior is zoned for maximized comfort. The public day use spaces are on the south, and the private predominantly night use spaces are on the north. To insulate, the 8 1/4" structural insulated panels [SIPs] in the walls and ceiling provide an R value of 30.5. The SIPs combined with the R 24 floor results in excellent insulation values and a tight envelope, an appropriate design approach for our target climate zone. To shade, the house uses multiple strategies, including both the bifacial room on the south as well as the redwood screen on the wings. To ventilate, all the windows are operable, including the north-facing clerestories in the taller core, which are designed to promote stack ventilation. To stabilize, a phase change material duct runs the length of the core, dampening temperature swings on the interior. To collect, the team specified both monofacial as well as bifacial photovoltaic panels for a combined rated power output of 9.3 kW [the house also powers an electric car].



Fig. 3: Bifacial Room [with bifacial photovoltaic panels]

4.2 Core | Wings

INhouse includes two wings - one public and one private - linked to an active core. On the exterior, the core and the wings are formally and materially differentiated through volume as well as materials. The passive wings are lower, more porous, and are defined by a redwood screen designed to shade the envelope as well as to highlight the origin of our project, the central coast of California. The taller active core is more sleekly designed, using panelized construction, and enclosing the home's comfort systems.

On the interior, the core and wing organization creates a separation of space that allows for an open floor plan for the public spaces, while maintaining the option of privacy. In addition, purpose-specific casework is integrated along the short ends of the wings, creating a "bookend" effect that minimizes clutter and defines space. These bookends are also an example of the project's overall holistic design. The bookends act as thermal buffers through their east/west orientation, acting as additional indicators of the project's climate responsiveness. They also provide spatial organization as well as material and textural interest to their adjacent spaces.

4.3 Inside | Outside

Connected by a 15 foot NanaWall®, the public wing seamlessly connects to a generous outdoor area, emphasizing the outdoor living potential afforded by the coastal California climate and doubling the home's public space. The outdoor decks provide residents with additional square footage that is essential for an otherwise modest house footprint. This outdoor space is adaptable through operable shading screens that allows user-defined comfort in response to the changing seasons. In the bifacial room, shading with bifacial PV panels not only offers refuge from the harsh southern sun but also provides additional power for the house. This includes some power gained through reflected light, one of the attributes of bifacial technology.

The constructed wetlands are an additional indicator of holistic design. In drought stricken California, progressive thinking about water use is essential. Greywater from INhouse is captured and channeled into the wetlands, transforming a resource that was once considered waste into a precious resource that provides a touch of natural delight for the inhabitants. Additionally, the other planters located around the walls of the house collect the rainwater from the roof. These small rain gardens are planted with local vegetation which become dormant in the off season.

5. In Pursuit of Quality

In order to realize the design intent of INhouse, Solar Cal Poly established a goal of selecting materials of superior performance and quality. The team selected materials based on thermal and environmental performance as well as durability. Many of the materials selected for the project come from the West Coast.

However, material performance alone is insufficient for delightful design; quality is essential to achieve delight. For the team, this translated into choosing materials not only for their aesthetic potential but also for their longevity.

With these filters established, the rationale behind the material selections for INhouse becomes clear. The envelope is predominantly constructed of structural insulated panels, which combine structure and insulation into one component, resulting in higher R-values, faster construction times, and a tight envelope.

On the exterior, the core and wings are materially differentiated from one another. The core utilizes a panelized material made with FSC® certified and post consumer waste paper content; it also requires no additional treatment. The wings are predominantly screened with locally sourced FSC® certified redwood. For performance, the redwood screen shades the envelope and is patterned as a solar thermal map of the house, with the denser areas indicating zones of higher solar intensity [Fig. 4]. For quality, the redwood identifies the project as a product of its region (coastal California) detailed and crafted to create a modern California aesthetic. On the south, the screen continues past the limits of the envelope to shade the exterior, providing privacy and creating a comfortable outdoor room.



Fig. 4: Redwood screen: as modeled (left) and as built (right)

On the interior, INhouse's contemporary aesthetic draws on a blend of light colors and wood to create comfortable and delightful spaces. The light walls are intended to work in concert with the architectural lighting to create an expansive feeling in the relatively small spaces. The flooring and bookends are intended as a gentle contrast, using the warmth of FSC® certified bamboo flooring and cabinet faces as a material counterpoint.

Also within INhouse is a material that is mostly hidden: phase change material [PCM]. Following good passive design principles means that INhouse needs thermal mass in order to dampen temperature swings and to better maintain thermal comfort. Most of this material is out of view, located in the phase change duct that runs the length of the core. In order to educate inhabitants, the team chose to display some PCM material through the more interactive art piece along the south wall.



Fig. 5: INhouse interior [dining room]

6. Conclusion: INnovation

Differentiating between the active core and the more passive wings exemplifies an aspect of INhouse's design ingenuity. Locating the active systems in a central core allows for more design freedom in the wings and thus presents an opportunity for replication without duplication. If replicated, the number of wings might be different, or in a different configuration. The core itself could be prefabricated and mass-produced. Either of these components could be fabricated for high-end or more modest clientele.

Creative use and expression of material was also a goal for INhouse. The use of PCM as a thermal moderator is one example. The use of the redwood as an expression of thermal shading and solar thermal mapping is another. Each of these represents an emerging chapter in the design professions, as we employ our parametric design tools to help us simultaneously achieve superior performance as well as delightful aesthetics.

Perhaps the Solar Cal Poly team could have designed a house that operates entirely independent of its residents, but a "smart home" is of less value to society than a "smart resident." This holistic approach stems from the shared vision and close collaboration between the many disciplines involved in creating INhouse. Residents of INhouse will be encouraged to learn how to live net-zero, and the house itself will be the vehicle of their education.

The Solar Cal Poly team presents a new standard of "in" by creating a notion of ecological living that is enticing as well as achievable. INhouse is an approach to living well, while still living within our ecological means.

Acknowledgements

The authors would like to acknowledge Cal Poly's College of Architecture and Environmental Design [Dean Christine Theodoropoulos] for its support of this project.

Photo credits: Thomas Kelsey/U.S. Department of Energy Solar Decathlon and Josef Kasperovich/Cal Poly



ASES National Solar Conference

Maryland Net Zero Energy Schools Program

David L. Comis¹

¹ Rockville, MD, USA

Abstract

The State of Maryland is in the midst of designing and building three schools that will meet the criteria of Net Zero Energy, meaning that they produce as much energy as they consume. At present, the construction of one school is about 75% complete, the design of one school is about 50% complete, and site selection for the third school is in progress. This paper describes the finances, programmatic decisions and initial lessons learned from the viewpoint of the state. This paper represents the author's personal opinions and does not reflect the official view of the State of Maryland.

Keywords: *NZE, Maryland, Net Zero Energy, school,*

1. Introduction & Program History

In 2012, the Maryland Public Service Commission approved the merger of Exelon Corporation and Constellation Energy. At the time of merger, Baltimore Gas and Electric Company (BGE) was a distribution utility for gas and electricity under Constellation Energy. As a condition of this merger, money was placed in certain Maryland accounts for various purposes: \$113.5M was placed in the state's Customer Investment Fund (CIF) for the purpose of providing improvements, including energy efficiency, to BGE customers (Public Service Commission of Maryland, 2012). From this fund the Maryland Energy Administration (MEA) requested and received \$9M for the purpose of incentivizing the development of three Net Zero Energy (NZE) schools.

2. The Money

MEA split the \$9M as follows: \$680K was designated for Architectural and Engineering (A/E) technical support for MEA and up to \$2.7M could be spent on each school. Of the \$2.7M designated for each school, up to \$533K was designated for support of the design process, while the remainder, about \$2.2M, was to be used to offset construction costs directly associated with achieving the NZE goal.

The Net Zero Energy Grant pays on a reimbursement basis, meaning that the school district must have already paid the bill before the money is reimbursed. The school district may request reimbursement at any time, although they normally tend to do so when they submit their mandatory quarterly status report and invoice.

3. The Policy

A number of program policies were instituted to support the success of the program:

- Because the source of the funding was the Customer Investment Fund, the funding could only be used within the Baltimore Gas and Electric service area.
- In order to maximize the opportunity to achieve the NZE goal, MEA decided that the program would only support NEW schools. This policy removed any school renovation projects.
- To prevent concentration of benefit in a single county, MEA intended to support only one school within a given school district. In Maryland, a school district constitutes an entire county.

- While state law requires new schools to meet the LEED Silver standard, some counties have instituted higher standards. To maximize the use of funds, MEA instituted the policy that the NZE program money could only be used to support upgrades from the county's existing standard to achieve Net Zero Energy status. As such, funding uses in one county might not be authorized in a different county with a higher baseline school design standard.

4. The Team

The MEA project team consists of an MEA Program Manager and two contractors who provide programmatic support. The MEA team arranges for the Grant, reviews the design documents, addresses funding questions, and continually monitors the project to ensure the design and construction of the project will result in a NZE school. An Architecture and Engineering team is contracted to support the MEA team in this effort. Their primary job is to review the design drawings at the various stages of design and answer one question: If the school is constructed and operated as indicated in the design documents, will the school achieve a net zero energy status? This A/E team is also authorized to make comments on the design, but this is not their primary duty, nor is the Architect of Record required to respond to their comments.

5. The Process

In Maryland, the normal process for the design and construction of a school is as follows:

The school district brings on an Architect of Record (normally a complete A/E team) and provides it with the school district requirements for the new school. The Architect of Record then provides Schematic Designs for approval by the school board. Design Development finishes the basic design, followed by the development of Construction Drawings. Following School Board approval, the plans are sent to the Maryland Public School Construction Program (PSCP) where the plans are reviewed and approved. Following State approval, the school district puts the plans out for bid using a Request for Proposal. Construction is conducted, the school is commissioned, and the students and staff move in.

The addition of the Net Zero Energy grant added a few steps to the process. First, the school district/county is authorized to hire a consultant A/E firm that has already designed a completed Net Zero Energy School using the \$533K provided in the Grant. Eight such firms were vetted and pre-qualified, and additional firms that meet the requirements will be considered if requested. Second, a design charrette was placed in the schedule before the schematic drawings were started. The charrette is designed to ensure a meeting of the minds between the designers and the other stakeholders who will ultimately have to operate under the design. This was considered to be a key step as certain areas are greatly affected by the shift to Net Zero Energy, specifically the cafeteria staff, the audio-visual department, and the maintenance staff. In some cases, people will need to be trained on new equipment, while in other cases, the entire school process will be changed. Ensuring that the new Principal and teachers are onboard with the required procedural changes is key to the success of the new school. Third, the MEA Team is involved in review of the plans and drawings at the schematic drawing, design development, and construction drawing phases. The MEA team (including the A/E contracted to support MEA) may make nonbinding comments, which the Architect of Record may use or discard, and may make formal comments which require formal response. Formal comments are used very sparingly and only for Net Zero Energy design issues, as these comments have the potential to be very disruptive to the design effort. Luckily, very few have been required. Finally, the MEA team monitors the construction effort through the end of the commissioning process. This monitoring normally consists of quarterly site visits, as well as weekly 15-minute phone calls to discuss status and any net zero energy related issues.

6. The Standard

The Energy Use Index, also called the Energy Utilization Index, but normally just referred to as EUI, is a measure of the energy (of any type) used per square foot of a building. In the United States its units are in thousands of British Thermal Units per square foot (kBtu/ft²) (kW/m² in SI units). While there is no national EUI standard for a Net Zero Energy school, MEA established its upper limit at 25 kBtu/ft² (78.86kWh/m²). It is important to note that this value includes not only school functions, but also after school functions and scheduled community use. As such, it is very important to know how the school will be used, both before, during, and after school hours, when calculating the expected energy usage. The form of renewable energy selected to supply the school is

regional specific. Solar photovoltaic (PV) technology is normally selected in Maryland. Ground source heat pumps also serve to provide heat during the winter, while serving as a heat sink during the summer.

7. The Status

Howard County, Maryland, elected to build a new Wilde Lake Middle School on the site of the existing middle school of the same name. The Net Zero Energy grant became available about the same time that Howard County selected its Architect of Record, so the timing was perfect. Even so, this being the first Grant of its type, it took 4 months to get the Grant signed by both parties. By then, Schematic Drawings had been completed and were ready for review. The design was based on a prototype, which had been previously designed by the Architect and successfully utilized by the school system five times prior to Wilde Lake. It was felt that a design charrette would still be of value so it was held with the kitchen, IT, and facilities management personnel at a date immediately following the schematic design review. The DD and CD phases went smoothly and the final drawing package was sent to the state for review in early January 2015. The drawings were approved and a construction firm was selected. Groundbreaking occurred in June 2015. The construction of the school is currently 75% complete. Staff and student move-in is scheduled for late December 2016. The school has 633 kW of roof and ground mounted solar photovoltaics, 527.5 kW (1,800 MBtu/hr) (527.5 kW) of heat pump capability, a building enclosure with R-25 walls and R-30 roof. Ambient lighting is maximized for the classrooms, with installed LED lights used to fill in the gap. Demand Controlled Ventilation (DCV) is used, where CO₂ content is used to determine when fresh air is added to a space. The kitchen is designed without a deep fat fryer. These are just the highlights as obviously there are many other energy saving measures designed into the school. The EUI, even with evening activities factored in is 22.6 kBtu/ft²/year (71.3 kWh/m²). This project has remained on its timeline since inception. There have been no major issues to address during construction.



Figure 1: Artist drawing of Wilde Lake Middle School
Architect of Record: TCA Architects
(Graphic provided by and used with the permission of TCA Architects)

Baltimore City, Maryland, elected to build a new Graceland Park - O'Donnell Heights Elementary/Middle School, also on the site of the existing school of the same name. Although the Grant agreement was in place in April 2014, Baltimore City did not move forward with the project until November 2015 when it sent out a Request

for Proposal. Unlike the Howard County process, this was a combined Design/Build contract, a single contract to cover the design and construction of the school. Also unlike Howard County, the school district asked an Architect whom they frequently worked with to lay out a preliminary design for the new school prior to the release of the RFP. As it turned out, Baltimore City selected a team that included this same Architect, and an Engineering firm that had already designed a successful Net Zero Energy School. Also unlike Howard County, Baltimore City decided that they did not need an A/E consulting team to help them with the design because of the strength of the selected A/E team. Instead, Baltimore City used some of the design money to pay the A/E team for additional studies that had been conducted by the A/E Consultant team during the Howard County project. The Design Charrette was held after the completion of Schematic Drawings. At present, the design team is concluding the Design Development phase. Assuming State approval of the Design Development drawings in August 2016 and the Construction Documents in January 2017, construction is expected to begin in June 2017, with student move-in December 2018. Although still subject to change, it appears this school will include 565 kW of roof mounted solar photovoltaics, 400 MBtu/hr (120 kW) of heat pump power, R-25 walls (ICF with exterior masonry cladding), and R-30 roof and many of the same kitchen and IT modifications used by Howard County



Figure 2: Artist conception of Graceland Park Elementary/Middle School
Architect of Record: Grimm & Parker
(Graphic provided by and used with the permission of Grimm & Parker, LLC)

Baltimore City will use this same design to replace another school (Holabird Academy - Elementary/Middle School) only three blocks away. This school will be Net Zero Energy Ready. Unfortunately, due to site layout considerations, this school must be rotated 180 degrees from the Graceland/O'Donnell orientation so a direct comparison of construction and school procedures will not be possible. Still, with both schools being so close together and using the same basic design, many comparisons will be possible.

The site for the third Net Zero Energy School has yet to be selected. Outside of Howard County and Baltimore City, none of the other counties in the BGE service territory have a new school under construction during the timeframe of this grant. Baltimore City has a number of new schools being built in the next few years, and at least three sites are under active consideration. Site selection is expected for August of this year.

8. Lessons Learned

Although the grant is nowhere near complete, and we haven't even finished one school, there are a few lessons learned from this project:

- 1) Ensure the Grant instrument is signed before the Architect of Record is selected if it is desired to have a design charrette before the Schematic Design is complete.
- 2) SHORT, weekly meetings with the school districts tend to work to keep track of status. Short prevents disruption of a lot of the workday for the school district manager. Weekly allows the occasional missed or cancelled meeting without losing track of status
- 3) It is better to have a Point of Contact who can be reached, even if that person is not the supervisor, than to

have a supervisor level Point of Contact who cannot be reached.

9. References

Public Service Commission of Maryland case #9271Order 84698 Issues February 17, 2012, *In the Matter of the Merger of Exelon Corporation and Constellation Energy Group, INC.*, https://archive.org/stream/293295-exelon-constellation-merger-opinion/293295-exelon-constellation-merger-opinion_djvu.txt , accessed June 20, 2016.

House Energy Doctor's Level III Building Energy Audits as Pedagogy and Outreach

Nader V. Chalfoun

University of Arizona, Tucson, Arizona (USA)

Abstract

Arizonans spend over \$9 Billion annually on primary energy consumption which is equivalent to the entire state budget. The building sector in Arizona consumes 45% of that energy. Many older pre-energy code buildings have poor performance, and consume immense amount of energy. The House Energy Doctor[®] (HED) program has developed an in-house tool set that includes the operation of specific site instruments and "Site Survey Forms[®]" to be used in conducting Level III energy audits for existing residential and commercial buildings. The energy audit is a major part of the Masters of Science in "Design and Energy Conservation" and is used in providing outreach service to building owners while fostering students hand-on inquiry based learning. Since 1986, outcome of using the established HED Level III energy audit process has been successful in yielding pronounced education opportunity for students and for homeowners alike, while providing an average of 50% savings in the total energy used by existing buildings. These results also have a great impact on improving building's operation, reducing cost, and minimizing the carbon footprint a valuable resource in the emergence of America's new energy economy. This paper describes the HED Level III advanced energy audit process, provides details of the distinctive in-house developed Site Survey Forms, their contents and method of use, and demonstrate successful case studies applied to campus building and residential community single family houses.

Keywords: *Energy Efficiency, House Energy Doctor, Energy Audit, Site Tools, Existing Buildings, Education*

1. Introduction

The United States total primary energy consumption was 97.1 quadrillion Btu in 2013 (DOE/EIA-0383, 2015). Building operation consumes 75.7% of the total electricity and 43.1% of the total energy. The state of Arizona spends over \$22 billion annually on primary energy consumption which is equivalent to the entire state budget, and this rate is increasing by 2-4% annually. The building sector in Arizona consumes 45% of that energy. Buildings also account for carbon emission, raw material use, waste output, and potable water consumption.

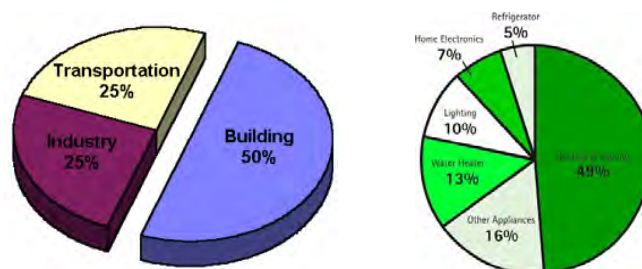

Fig. 1: World energy consumption (left) and energy consumption by type (right)
Source: Energy Information Administration (2008).

In the residential sector, single-family homes account for over two-thirds of total delivered energy use. In the commercial sector, office, retail, and educational facilities use nearly half the delivered energy. With 90% of the housing units in Arizona are pre energy code, energy saving opportunity is great and can be achieved through energy audits and retrofit strategies. At the University of Arizona's CAPLA this opportunity was realized through the inception of the House Energy Doctor© (HED) program.

2. The House Energy Doctor® program

Since 1986, the “House Energy Doctor” (HED) program¹ is an education, research, and community outreach program developed by Dr. Chalfoun at the University of Arizona's College of Architecture, planning and Landscape Architecture (CAPLA). The program provides service while fostering hands-on inquiry based learning of high performance green architecture, energy conservation, and passive solar designs. It uses advanced field investigation methods of existing buildings and cutting edge energy audits. During the last 3 decades the program serviced over 140 residences, 32 commercial, 6 institutional, 4 medical buildings, and two National Parks, had over 120 publications, and conducted over 22 workshops worldwide. The program was developed into a full one-and-a-half year Masters of Science in Architecture curriculum and in 2012 was awarded the “Best Energy Education” in Pima County by the Department of Energy.



Fig. 2: House Energy Doctor© program at the University of Arizona

The program offers energy education through 1) Studios, 2) courses, 3) empirical research laboratories, and 4) Thesis development. One of the most important achievement of HED is the establishment of the Tucson's first residential annual heating and cooling baseline consumption of 55.6 kBtu/ft². This index was then used to develop the first energy code that was implemented in Pima County². The research findings demonstrated methods to save over 60% of existing buildings' heating and cooling consumption using different levels of advanced energy audits.

3. HED Advanced Level III Residential Energy Audits

Energy audits can be interpreted in many different ways by individuals depending on the scope, complexity, and required level of evaluation. Thus energy audits techniques must be defined in advance. The HED program developed three major energy audit levels increasing in complexity and based on project goals and time spent on site. Level I: Basic walk-through observation, Level II: Walk through with instrumentations and measuring tools, and finally Level III: consists of the Level II and conducting energy simulation, optimization and recommendation for improvement that includes return on investment analysis.



Fig. 3: House Energy Doctor© Levels of Energy Auditing

3.1. Energy Audit Level I

This is the simplest and shortest energy audit process that requires few hours spent on the facility. HED students walk through the buildings guided by building owner or homeowner. They conduct visual inspection of the building envelope and the mechanical and lighting systems taking notes and photographs. Typically, utility bills are collected and compared with industry standard benchmarks to identify potential savings. A short report is sent to the building owner shortly after inspection.

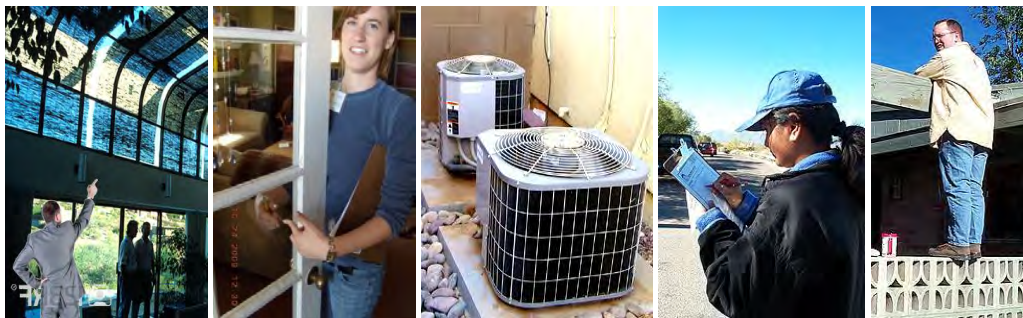

Fig. 4: House Energy Doctor© Level I energy audits

3.2. Energy Audit Level II

This level is considered a standard audit but with instruments. It often requires more than one day tour of the facility to quantify energy usage through more detailed review of the building envelope, equipment, HVAC systems, and operational characteristics (efficiency). On-site measurements and testing of performance is conducted using site tools and instruments. Example of these tools are roof inclinometer, solar reflectance pyrometer, thermometers measuring supply and return temperatures, clocking the electric meters using stopwatch, air-balancers to measure and balance volume of air supplied by the duct system, etc. An interview with the building owner is also conducted that reveals time of use, thermostat settings, appliances schedule, and more.



Fig. 5: House Energy Doctor© instruments used in Level II energy audits

Standard energy engineering calculations are used to analyze efficiencies and calculate energy and cost savings based on improvements and recommended changes. This Level II audit often include economic analysis of recommended conservation measures.

3.3. Energy Audit Level III

This is considered HED's most comprehensive evaluation of energy use patterns of buildings achieved through the use of advanced data collection methods combined with industry standard computer simulation techniques. The simulations account for weather and other variables to predict typical year-round energy use profile. This level requires site visits activities and data collection beyond those conducted in Level II. For example a blower door test is required and all appliances and electric lighting systems must be documented in details. Students use an in-house developed instrument called Azimuth Protractor© (developed by Dr. Chalfoun) to accurately measures building orientation. The mechanical system efficiency is measured on site and a special set of site forms are used to accurately collect all the needed data.



Fig. 6: House Energy Doctor© level III energy audits

After the elaborate site visit, students auditors energy simulation software to develop a baseline energy usages of the as-is building. The baseline performance must be validated by comparing it with the actual utility bills and make sure the predicted consumption falls between $\pm 20\%$. Auditors then conduct parametric analysis by making one-at-a-time changes to improve the efficiency of various building and mechanical systems as compared to the baseline performance. An optimized case is then developed and reported to the building owner after a thorough economic analysis that proof the best return on investment to the client.



Fig. 7: Validation of the Basecase simulation results

Because of the time involvement in this level, considering the detailed data collection and accurate computer energy and economic modeling, this is considered the most time consuming and most expensive level of energy auditing conducted by HED.

4. HED Site Survey Forms

In 1996, the House Energy Doctor program received a grant from the Department of Energy to develop a special set of site survey forms to be used during the different levels of energy audits. The forms are developed to help students collect comprehensive and complete data during their visit to the building avoiding revisits due to any missing information. This important if sites are in remote locations and require traveling time and expenses. The forms also provides valuable information on building material and systems performance such that it could be used as a teaching tool to students and building owners alike. There are 28 site survey forms and some are repetitive for larger buildings where for example the number of openings exceeds the maximum numbers on the forms. Duplicate forms could then be used. All forms are available for download on the House Energy Doctor website: <http://hed.arizona.edu/hed/>. They have been used by many students and clients not just for conducting Level III energy audits but also for research purposes.

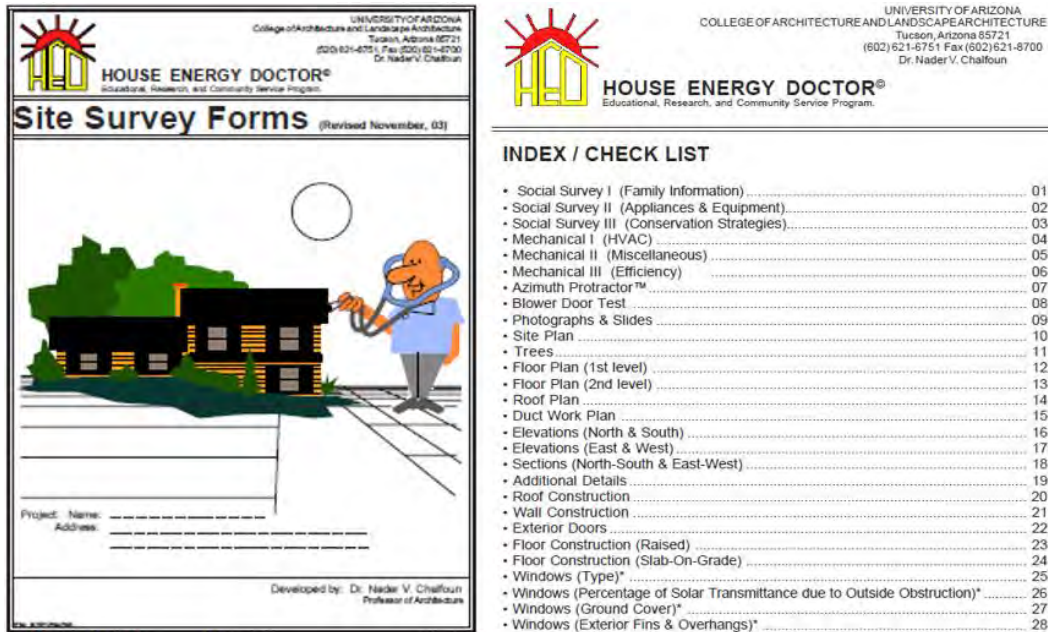

Fig. 8: HED Site Survey Forms

The forms basically represents three major aspects of take-off data from site; 1) Social survey forms, 2) Envelope forms, and 3) Mechanical systems.

4.1. Social Survey Forms

These forms are used by the students during the audit. They interview the building owners to get information on the building use profile and internal loads, etc. The forms cover 10 main topics, these are:

1. Family Size
2. Family Daily Pattern
3. Guests and Visitors
4. Vacations
5. Thermostat Settings
6. Demand Charge Account
7. Inventory of Household Appliances
8. Usage Patterns of Common Household Appliances
9. Proposed Conservation Strategies
10. Proposed Budget upgrade/retrofit Budget



Fig. 9: HED students conducting the social survey

An important function of one of the forms is to question the building owner about favorable energy conservation strategies that he/she would like investigated. It also ask building owners whether they have an allocated budget for upgrade/retrofit and the approximate dollar amount.

4.2. Envelope Data Forms

These forms are used to document all the envelope information needed for computer simulation. For example, one form is used to identify the exact building orientation in relation to south. Homeowners usually do not have this information and underestimate its importance. When they are asked about the orientation of their building they usually eye ball pointing to the south.

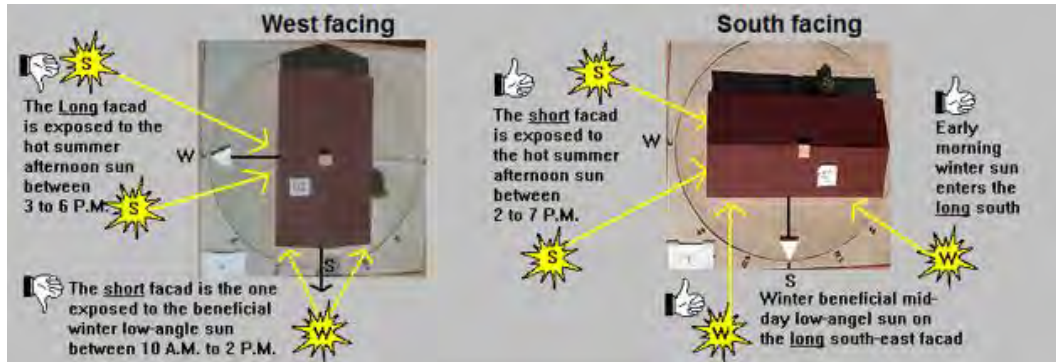

Fig. 10: Importance of building orientation

Professor Chalfoun has developed a patented instrument called “Azimuth Protractor[®]”. It is a device for determining accurately the exact angle of orientation (or azimuth) of any given surface wall or site boundaries relative to the true south orientation. The device takes into consideration longitude correction, equation of time correction, and true versus magnetic north. Associated with the device is a software AP[®] written in ACAD Lisp language, which generates AP Charts for the specific day of the site visit. The charts are mounted on the device platform before going to site. The sun shadow of the 2”, 3”, or 4” pin is observed and aligned with the chart a protractor arm is swung out to align with the wall, and the azimuth angle could be read on the engraved protractor.

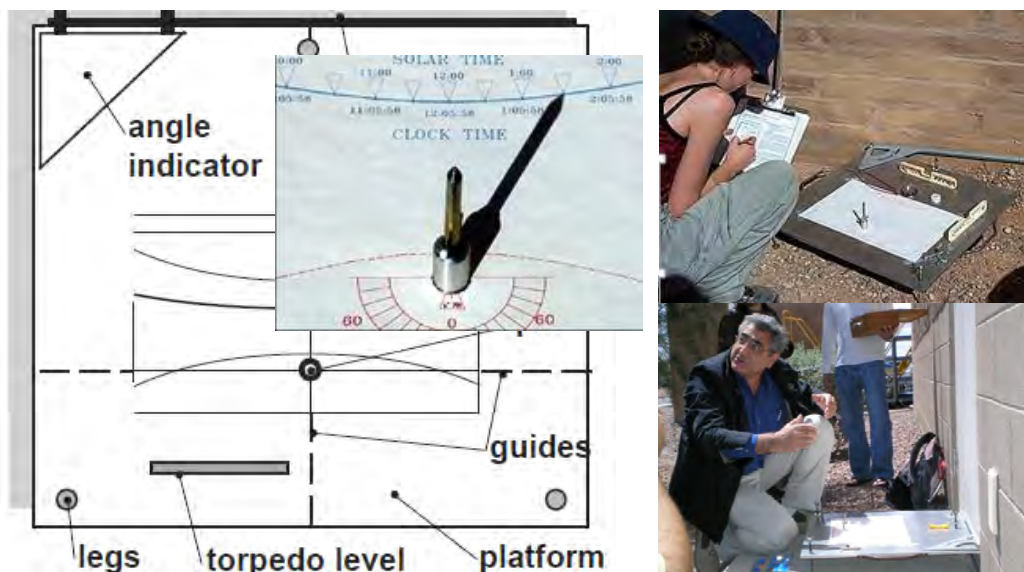

Fig. 11: The “Azimuth Protractor[®]”.

Information about the envelope leakage is measured on site using a blower door instrument. A blower door has a large calibrated fan that is temporarily mounted in a house door to measure the "leakiness" of the house and to assist in finding the location of the leaks. To measure the leakiness of the house, both the air flow through the fan and the differential pressure created across the house walls must be measured.



Fig. 12: The Blower Door experiment

When the envelope is depressurized and the 50 Pascal is achieved, the number of CFM and the volume are used to calculate the air leakage in a Air Change per House ACH format.

$$ACH_{50\ natural} = \frac{60 \times \text{Air Flow (cfm)} \times \text{blower door factor}}{17 \times \text{House Volume(cf)}} \quad (\text{eq. 1})$$

When the blower door fan is reversed, the envelope is then pressurized and the leaks could be detected through the use of smoke sticks. Additional envelope investigation techniques by the House Energy Doctor is measuring shortwave reflectance, using thermal camera to identify thermal bridges, locate trees and major landscape objects that might have effects on the interaction between the sun and the building, in addition to sketching and naming object for identification in the computer model.



Fig. 13: Above, auditors using thermal camera, measuring internal dimensions, roof tilt and sketching facades, Below: An infrared photo showing the CMU wall with thermal bridges through the grout

4.3. Mechanical System Forms

These forms are used to document data on the building's HVAC system that was either measured by the students or read of the equipment stickers. One important variable that has the greatest potential on simulated energy conservation number is equipment efficiencies. The HED auditor actually measures on site the actual running coefficient of performance (COP) of a heatpump or an AC unit through a three-step process; 1) use the air-

balancer instrument to measure the CFM capacity of the ductwork, 2) use a stop watch to clock the meter and measure the power of the system, and 3) after measuring the supply and return temperatures of the system we use the following equation to obtain the COP:

$$COP = \frac{\text{Capacity } (\frac{Btu}{hr} \text{ or } kW \text{ output})}{\text{Power } (\frac{Btu}{hr} \text{ or } kW \text{ input})} \quad (\text{eq. 2})$$

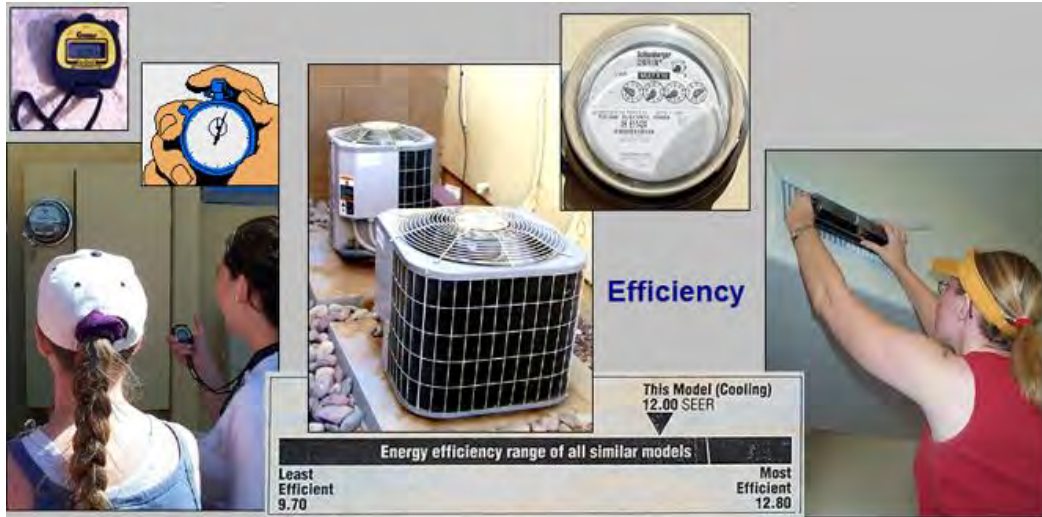

Fig. 13: Identifying system's COP by clocking the meter.

5. Commercial Energy Audit

Through a multiyear agreement between HED and the UA, Level III energy audits have been conducted on nine major campus buildings to identify energy efficiency opportunities that will contribute to the greening of campus. Some of the important findings are focused on replacement of inefficient windows, adding external insulation, shading for most of critical building elements, replacement of energy-saving light fixtures, and proposing change of envelope colors to increase solar reflectance in summer. Strategies for mechanical systems propose changes to current thermostat set points, run periods, replacement of old components with higher efficiency units, and water harvesting of condensates for landscape use.

The first three years of the "Greening of Campus" project demonstrated that the nine buildings total area of 1,081,512 ft² consumed an annual average 75,970,411 KBtu (70.2 KBtu/ft²) at the cost of \$2,186,264 per year. Implementation of the House Energy Doctor recommendations for the nine buildings will yield an annual energy savings of 9,542,106 KBtu and operating cost saving of \$265,318 (12.1%). This energy saving will help the environment by a reduction of 2,915 Metric tons of CO₂ emission. The campus will also be saving 10.9 million gallons of water, an important environmental benefit for desert communities like the University of Arizona. In addition, two of nine buildings "Arizona-Sonora" and "La Aldea" have been successfully certified for Energy Star Designation.



Fig. 14: University of Arizona Buildings.

6. Conclusion

The House Energy Doctor program at the University of Arizona is aiming at graduating new generations of informed energy conscious architects focused on green building design and reduced consumption. Since 50% of the nation's energy is consumed by buildings, the expected energy saving results are enormous. The savings also reduce greenhouse gas emission created by the generation of electricity that pollutes the air, causes climate change, and has adverse effects on human health, as well as negative biological impacts on plants and animals. Energy production is also depleting the water supply, a critical aspect of desert communities like Arizona. For example for every kWh of electricity generated, 2/3 gallon of water is consumed at the site of thermoelectric power plant. Arizona produces 17% of its energy from Hydroelectric, at the Hoover dam which actually consumes 65.85 Gallons per kWh (Torcellini et al. , 2003).

Since 1983, the House Energy Doctor program provides advanced level III energy audits and recommendations and has served over 140 residences, 30 commercial and 16 institutional buildings. With its hands-on inquiry based learning, the program has over 100 publications, and conducted numerous national; and international workshops. Through the years, the program has developed tool kits, instruments, and a set of special Site Forms that are used in the advanced energy audits. A Master's of Science in Design and Energy Conservation has been developed around the program that includes 14 graduate and upper division undergraduate courses, all centered around energy and water.

The average energy savings from the level III audits will have the greatest potential in reducing state energy consumption in buildings by at least 50%, significantly reduce green house gas emissions, mitigate climate change, and promote healthy living. On the University of Arizona campus, the HED process has now expanded to include all university buildings and in the last two years nine more buildings have been studied for retrofit by the House Energy Doctor program. The University of Arizona is the only university in the state with a diverse architecture, engineering, and environmental science expertise, and we witness now that more departments are joining the efforts with HED in Architecture.

7. Acknowledgment

The author would like to acknowledge all the national and international House Energy Doctor students who participated in the program and contributed to its success. They played the major role of conducting the energy

audits and generated professional reports that contributed to savings in the state of Arizona and other communities. The author would like to also acknowledge the building owners who collaborated with the program faculty and students to facilitate the level III energy audits. I also would like to acknowledge Christopher Kopach, assistant Vice President, Facilities Management, Joseph Thomas Energy Conservation Manager at the University of Arizona, and James Van Arsdel, Assistant Vice President for Student Affairs. Special appreciation for all the buildings' Managers who facilitated the energy audits and provided faculty and students us access to the buildings.

8. References

DOE/EIA-0383, 2015. Annual Energy Outlook 2015, with projections to 2040. U.S. Energy Information Administration, Office of Integrated and International energy analysis. U.S. Department of Energy, Washington, DC 20585. [www.eia.gov/forecasts/aeo]

Chalfoun, N.V., 2013. "A Method for Greening University Campus Buildings While Fostering Hands-on Inquiry-Based Students' Learning", 6th International Multi-Conference on Engineering and Technological Innovation: IMETI 2013, July 9-12, 2013 ~ Orlando, Florida, U.S.A.

Chalfoun, N. V., 1991. The "House Energy Doctor©; an Educational, Research and Community Service Program at the College of Architecture, the University of Arizona. Proceedings of the Design for Desert Living Symposium, Jul. 21-26, Tucson, AZ, USA.

Chalfoun, N.V. et al, 1991. "Passive Solar and Energy Optimization for a Residential House Type in Tucson, Arizona: A Case Study for the Solar Village Project. International Solar Energy Society (ISES) Solar World Congress. Aug.17-24 1991, Denver, Colorado.

Chalfoun, N. V., and Michal, J. R., 2003. Thermal Performance Comparison of Alternative Building Envelope Systems: Analysis of five Residences in the Community of Civano, Architectural Research Centres Consortium (ARCC), College of Architecture and Environmental Design, ASU, Phoenix, Arizona, April 10-12, 2003.

Torcellini, P. et al., 2003. Consumptive Water Use for U.S. Power production: Technical Report, National Renewable Energy Laboratory (NREL), NREL/TP-550-33905, Golden, Colorado, U.S.A., pp. 5, Table 3.

Resource Assessment: Models & Data



Solar Energy Assessments: When is a Typical Meteorological Year Good Enough?

Sophie Pelland¹, Charles Maalouf², Renée Kenny¹, Louise Leahy¹, Brad Schneider¹ and Gwendalyn Bender¹

¹ Vaisala, Seattle (U.S.A.)

² Independent, Seattle (U.S.A.)

Abstract

This study compares probability-of-exceedance values (P-values) for photovoltaic systems derived using multiple years of Vaisala's 3TIER Services weather data to those derived using a Typical Meteorological Year (TMY) based on the same resource data. Both approaches were used to estimate the year-1 yield of eighteen Megawatt-scale photovoltaic projects located in different parts of North America, South America and Asia. P-values in the TMY case were derived by using the standard deviation of annual global horizontal insolation as a proxy for inter-annual variability. All other uncertainties were treated identically in both approaches. Since our analysis included only eighteen case studies, we supplemented it by examining extreme cases where the differences between the two approaches should be maximum, namely cases where inter-annual variability dominates all other uncertainties. P50 values derived from a 3TIER Services TMY are usually within 0.5% of those derived using a full time series. Meanwhile, other P-values derived using a TMY exhibited a positive bias, indicating that this approach systematically underestimates uncertainty. A simple method for removing this bias was developed using ten projects as a training data set, and tested on the remaining eight projects. Overall, differences in P90 and P99 values are typically less than 1%, but can reach up to 2-5% in extreme cases. These results can serve as benchmarks for deciding whether and when TMY analysis is good enough.

Keywords: *Photovoltaic system, energy modeling, Typical Meteorological Year, TMY, energy assessment*

1. Introduction

Typical Meteorological Year (TMY) files provide one year (8760 hours) of synthetic weather data that is meant to capture a typical year. They are constructed from an underlying long-term, multi-year time series of meteorological data, with the aim that the annual energy yield from a TMY simulation should match as closely as possible the mean yield obtained by running a simulation over the full time series.

Currently, many photovoltaic (PV) simulation tools make it fairly easy to run simulations over multiple years of weather data. Such multi-year simulations provide distributions of annual energy yields which give an indication of the inter-annual variability that can be expected for a given project.

Meanwhile, TMY simulations cannot strictly speaking provide any information about inter-annual variability. On the other hand, simple statistics from the underlying long-term time series can provide such information. For instance, the standard deviation of the annual global horizontal insolation (GHI) can be used as a proxy for estimating the standard deviation in energy.

This study addresses the question: when is it worthwhile to run a simulation over a full time series, and when is TMY analysis good enough? Specifically, we compare probability-of-exceedance values (P-values) derived

using both approaches, where inter-annual variability in the TMY approach is approximated using the standard deviation in annual GHI. Since both approaches are still commonly used even for Megawatt-scale projects, the aim of our analysis is to help guide decisions about which approach to use in any given case.

2. Methodology

This study is based on eighteen energy assessments that Vaisala conducted for Megawatt-scale photovoltaic projects. Projects are located in various parts of North America, South America and Asia. They include fourteen projects with single-axis horizontal East-West trackers and four with fixed (or seasonally varying) orientations. Some projects are at the pre-construction stage, while others are already operational.

Probability-of-exceedance values were generated corresponding to the year-1 yield of the projects. This is the first year of operation for new projects and the upcoming year for operational projects. Specifically, P50, P75, P90 and P99 values were calculated. These indicate, respectively, the energy yield which a PV project has a 50%, 75%, 90% and 99% probability of exceeding during year-1.

2.1. Full Time Series Simulations

Full time series simulations were conducted using 3TIER Services meteorological data as input to the PVsyst simulation software (PVsyst, 2016). Vaisala's 3TIER Services derives irradiance using images from the visible channel of satellites in geosynchronous orbit. The ground resolution of the data is approximately 3 km and images are collected every 10-60 minutes depending on the region and time period. A proprietary algorithm is used to convert the satellite-observed images into ground irradiance (Vaisala, 2016). Wind and temperature data are constructed using the Weather Research and Forecasting (WRF) Numerical Weather Prediction model using reanalysis data for initial and boundary conditions. The time series for the eighteen project locations covered between 16 and 19 years, ranging from 1997 to 2016.

For each project, PVsyst was run in batch mode to generate annual energy yields for each year of weather data, returning 16 to 19 year-1 yields. These multiple year-1 yields were then used to construct a probability distribution of year-1 yields using kernel density estimation (KDE).

Kernel density estimation is a non-parametric method of estimating the probability density function of a random variable (Silverman, 1998). Kernel density estimators are a generalization over empirical histograms, which are often used. Estimating a density function with a histogram involves dividing the data into bins of equal width, then counting the number of observations falling within each bin. This leads to a density estimator that is not smooth and highly dependent on the end points of each bin, as well as the width of the bin. Kernel density estimators center a kernel function at each observation, averaging out the contribution of all observations over a local neighborhood of the given observation. Using a continuous kernel function also yields a smooth estimator. This alleviates the first two issues of the histogram above. Unfortunately, there remains the issue related to the bandwidth of the kernel function, similar to the width of a histogram's bins. A bandwidth that is too small will result in a highly variable density estimate, while a bandwidth that is too large will result in a biased one. It is very important to select an appropriate bandwidth value. In this analysis, we selected bandwidths using a cross-validation approach, where data points were withheld one at a time, and the bandwidth leading to the maximum total log-likelihood over withheld data points was selected.

2.2. Typical Meteorological Year Simulations

Vaisala creates TMY datasets using an empirical approach that selects four-day samples from the full time series to create a "typical year" of data with 8760 hours, while preserving the monthly and annual means of either global horizontal irradiance (GHI) or direct normal irradiance (DNI). The process is iterated until the monthly and annual means of both GHI and DNI in the TMY dataset match the means of the full time series to within roughly 0.5% or less.

The TMY datasets were used as inputs to PVsyst for each of the eighteen projects. The resulting year-1 yield was interpreted as the mean of a normal distribution of year-1 yields. In order to estimate the standard deviation of this distribution, different proxies for the standard deviation in year-1 yield were evaluated, the best of which was found to be the standard deviation in annual GHI.

Figure 1 shows the standard deviation in the year-1 energy yields obtained through the full time series simulations vs the standard deviation in GHI. As can be seen from this figure, the standard deviation in GHI tends to systematically underestimate the standard deviation in energy. We therefore considered two versions of the TMY approach: one in which the standard deviation in GHI was used directly and another, which we refer to as “TMY-adjusted”, in which corrections to the standard deviation in GHI were made to partly compensate for biases. These corrections were developed on the first ten projects that we analyzed, which included eight tracking systems and two fixed tilt systems. These ten projects acted as our training data set, while the next eight projects were used as a testing data set on which to independently validate the corrections developed using the first ten projects.

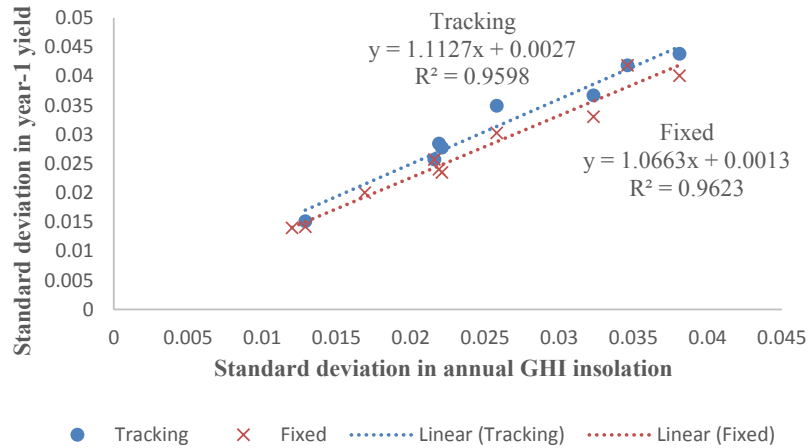

Fig. 1: Standard deviation in year-1 yield vs. standard deviation in annual GHI for fixed and tracking systems. All standard deviations are expressed as fraction of the annual mean. Note that for the purposes of this fit, fixed orientation equivalents to the eight tracking projects in the training data set were modeled.

The first correction was to use the Figure 1 linear fits to estimate standard deviation in energy from standard deviation in GHI. Separate fits were performed for tracking systems and for fixed tilt systems, as shown in Figure 1. A second linear adjustment was made to account for the fact that, in the TMY approach, year-1 yields are treated as normally distributed, whereas in the multi-year time series approach the more general KDE distribution is used. It turns out that the KDE distributions tend to have fatter tails than the normal distributions. Obviously, since KDE distributions and normal distributions generally have different shapes, it's not possible to match these up completely. As a proxy to this, the P90 and P50 values from the KDE distributions were used to calculate the standard deviation of a normal distribution matching these two P-values. The resulting standard deviation was then fitted linearly against the standard deviation of the original normal distribution as shown in Figure 2.

The standard deviation of the year-1 yield in the adjusted-TMY approach was thus calculated as follows: the standard deviation in year-1 yield was estimated by using the standard deviation in GHI as input to the fit in Figure 1 (fixed or tracking), which was used as input to the fit in Figure 2. Additional uncertainties were also included in the adjusted-TMY approach to account for the standard error in the Figure 1 and Figure 2 fits, as well as for the uncertainty of about 0.5% or less on the P50 that comes from using a TMY. The overall uncertainty associated with inter-annual variability in the adjusted-TMY approach was calculated assuming that each of these sources of uncertainty are independent of each other, so that the overall standard deviation is given simply by the square root of the sum of their squares. Equation (1) gives this overall standard deviation, σ_{IAY} , as a function of the standard deviation in annual GHI, σ_{GHI} .

$$\sigma_{IAY} = \sqrt{a\sigma_{GHI}^2 + b\sigma_{GHI} + c} \quad (\text{eq. 1})$$

where $a=1.0401$, $b=0.02036$, $c=0.0001482$ for tracking systems, and $a=0.9550$, $b=0.0170$, $c=0.0001238$ for fixed systems.

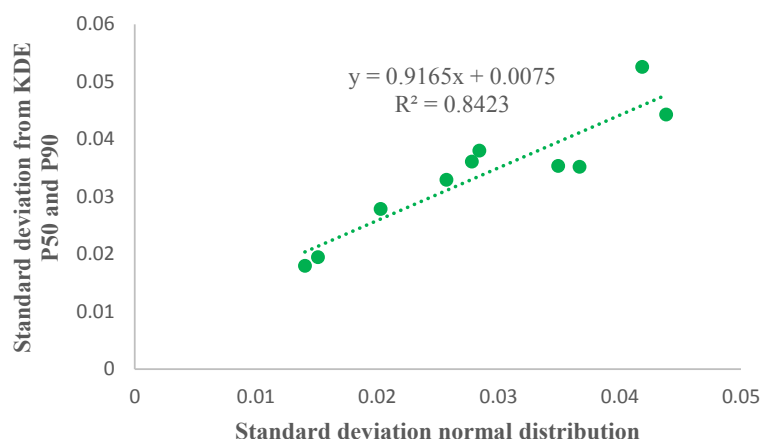

Fig. 2: Standard deviation of a normal distribution calculated from the P50 and P90 of the KDE distribution vs. standard deviation of the original normal distribution.

2.3. Overall Uncertainty in Year-1 Yield and P-values

Uncertainties not associated with the inter-annual variability in the weather were treated identically across all approaches. These uncertainties can be classified into the following categories:

- **Resource modeling:** Resource modeling uncertainty captures the uncertainties related to the accuracy of the satellite derived irradiance data utilized in the energy assessment, excluding uncertainties associated with climate variability. In some cases, this uncertainty is reduced by making adjustments to the satellite data based on comparisons with ground station measurements. Since projects can sometimes span more than one satellite pixel, a spatial component is included in the resource uncertainty to reflect the pixel-to-pixel variability in the solar resource.
- **Power modeling:** Power modeling uncertainty considers each step in converting solar irradiance estimates into energy estimates. This uncertainty captures the following: uncertainty in the transposition model used to derive irradiance in the plane of the array, bias in the simulation model itself and uncertainties in the inputs to the simulation model. Uncertainties in simulation model inputs include uncertainties in PV system specifications and uncertainties in the various losses that can reduce PV system output.
- **Aging:** The rate at which photovoltaic systems experience degradation is subject to uncertainty. Vaisala uses technology-specific median long-term degradation rates based on an extensive review of the existing scientific literature by NREL (Jordan and Kurtz, 2011). The difference between the degradation rate corresponding to the module manufacturer's 25-year minimum output warranty and the median degradation rate is used to determine the uncertainty in the annual degradation rate. Uncertainty in the annual degradation rate is then propagated over the time period of interest to yield an overall aging uncertainty. Note that for year-1 yields, this uncertainty is typically quite small compared to the other sources of uncertainty.

These uncertainties were combined with the inter-annual distributions in year-1 yield (either KDE or normal distributions) to generate an overall cumulative distribution function from which P-values were obtained.

2.4. Analysis of Extreme Cases

Since our analysis is based on a fairly small sample of eighteen projects, it may not pick up extreme cases where the difference between the TMY approach and the full time series approach is most pronounced. We conducted two analyses to try to expand our results to capture extreme cases. Since uncertainties other than inter-annual variability are treated identically in the TMY and full time series approaches, the differences between the two approaches should be most pronounced when inter-annual variability is large relative to other uncertainties. In order to explore this, two hypothetical projects (one tracking, one fixed) were simulated at a location near Pades, Romania, where inter-annual variability is high. All other uncertainties were set to realistic minimum values.

The second extreme case analysis consisted of calculating P-values for each project neglecting all uncertainties except inter-annual variability. This essentially mimics the case where other uncertainties are negligible compared to inter-annual variability.

3. Results and Discussion

The main results of our analysis are shown in Tables 1 and 2. These give percent differences between P-values calculated using the TMY and TMY-adjusted approaches and P-values calculated using the full time series, for the ten projects in the training data set (Tab. 1) and the eight projects in the testing data set (Tab. 2). If we consider first the P50 values, the mean difference is 0.1% in both cases, with standard deviations of 0.3-0.4% and a maximum of 0.8%. This is in line with the fact that 3TIER Services TMY means typically match long-term means of annual insolation to within 0.5%. These results can be compared to those of Ryberg et al. (2015), who simulated PV system yield at 239 locations in the United States by running simulations for representative fixed and tracking systems using both 30-year time series and TMYs. Their TMY results differed from their 30-year P50 values by up to $\pm 4\%$ in some cases. The cause of this difference is not clear: it is probably due in part to differences in how well the NREL TMY means match the means of the underlying time series, but could also be due to cases where the means and P50 values in the 30-year distributions differ substantially.

Considering other P-values in Tables 1 and 2, the TMY approach without adjustment tends to underestimate uncertainty, as expected, leading to P-values that are too high. This is reflected in the fact that the means for all P-values in this approach are positive. Meanwhile, the TMY-adjusted approach leads to P-values that are on average very close to those derived using the full time series. This is true both for the training and the testing data sets, showing that the bias correction works outside of the context in which it was developed. The largest differences in P-values between the TMY and full time series approaches are of the order of 2% in the unadjusted case, and less than 1% in the adjusted case.

In the extreme case scenarios discussed in Section 2.4., differences in the P90 reach 3.6% in the unadjusted case and 2.0% in the adjusted case, while differences in the P99 reach 5.3% in the unadjusted case and 3.2% in the adjusted case. Although their analysis differed from ours in a number of ways, it is still instructive to compare our results to those of Ryberg et al. (2015). Since their analysis considered only inter-annual variability as a source of uncertainty, it can be re-interpreted as an extreme case where this source of uncertainty dominates. Ryberg et al. (2015) provided TMY results as well as standard deviations in energy and P90 values for each location. We re-analyzed their results to compute P90 values for each location using the TMY mean and the standard deviation, and compared this to the P90 values they derived from empirical distribution functions based on 30-year simulations. Differences between the two P90 values reached up to 3-4%.

Tab. 1: Percent differences between P-values calculated using TMY approaches and full time series for the ten projects in the training data set

Project #	P50	TMY			TMY-adjusted		
		P75	P90	P99	P75	P90	P99
1	0.8%	1.0%	1.3%	1.5%	0.8%	0.7%	0.3%
2	-0.7%	0.0%	0.7%	1.7%	-0.4%	-0.2%	0.0%
3	0.1%	0.5%	0.9%	1.8%	0.1%	0.2%	0.4%
4	0.4%	0.7%	0.8%	0.9%	0.2%	0.0%	-0.8%
5	0.5%	0.9%	1.1%	1.1%	0.4%	0.1%	-0.9%
6	-0.2%	0.0%	0.3%	0.9%	-0.4%	-0.4%	-0.5%
7	0.2%	0.4%	0.5%	0.9%	0.0%	-0.2%	-0.5%
8	0.0%	0.0%	0.1%	0.2%	-0.2%	-0.3%	-0.6%
9	-0.2%	0.2%	0.6%	1.7%	-0.1%	0.1%	0.5%
10	-0.1%	0.2%	0.6%	1.2%	-0.1%	0.0%	-0.1%
Mean	0.1%	0.4%	0.7%	1.2%	0.0%	0.0%	-0.2%
Standard deviation	0.4%	0.4%	0.4%	0.5%	0.4%	0.3%	0.5%
Maximum	0.8%	1.0%	1.3%	1.8%	0.8%	0.7%	0.5%
Minimum	-0.7%	0.0%	0.1%	0.2%	-0.4%	-0.4%	-0.9%

Tab. 2: Percent differences between P-values calculated using TMY approaches and full time series for the eight projects in the testing data set

Project #	TMY				TMY-adjusted		
	P50	P75	P90	P99	P75	P90	P99
11	-0.3%	0.0%	0.3%	1.0%	-0.2%	-0.2%	0.0%
12	0.3%	0.4%	0.4%	0.5%	0.2%	0.1%	-0.2%
13	0.4%	0.7%	1.0%	1.7%	0.5%	0.5%	0.7%
14	0.2%	0.7%	1.0%	2.0%	0.3%	0.4%	0.7%
15	-0.3%	-0.2%	-0.1%	0.3%	-0.4%	-0.5%	-0.6%
16	0.0%	0.1%	0.2%	0.3%	-0.1%	-0.2%	-0.4%
17	0.5%	0.9%	1.2%	1.8%	0.6%	0.6%	0.7%
18	0.0%	0.2%	0.4%	0.7%	-0.1%	-0.3%	-0.6%
Mean	0.1%	0.3%	0.6%	1.0%	0.1%	0.1%	0.0%
Standard deviation	0.3%	0.4%	0.5%	0.7%	0.4%	0.4%	0.6%
Maximum	0.5%	0.9%	1.2%	2.0%	0.6%	0.6%	0.7%
Minimum	-0.3%	-0.2%	-0.1%	0.3%	-0.4%	-0.5%	-0.6%

4. Conclusion

This analysis started with the question: when is a TMY solar energy assessment good enough? Obviously, there is no hard-and-fast answer to this question. It will depend in particular on which TMY dataset is being considered, on user requirements as to what constitutes an acceptable difference between TMY and full time series analyses, as well as on specifics of the PV project, including the relative size of inter-annual variability and of other uncertainties.

Having said that, this study does provide some rough benchmarks to help address this question. First, it shows that differences in the P50 closely reflect differences between the TMY means and the long-term time series means of GHI and DNI. In the case of the 3TIER Services TMY, this difference is usually less than 0.5%. For other P-values, our analysis shows that using the standard deviation in GHI as a proxy for inter-annual variability in the yield tends to systematically underestimate uncertainty, but also that this bias can be removed through simple corrections. With this correction applied, differences in P-values between the TMY-adjusted and full time series simulations for the eighteen PV projects analyzed were all less than 1%. However, our analysis also suggests that differences in P-values can reach up to 2%-5% in extreme cases where inter-annual variability dominates all other uncertainties. Such cases could correspond for instance to operational reforecasts in regions with high inter-annual variability, since power modeling and resource modeling uncertainties can often be significantly reduced when past project performance and weather data are available.

One way to decide whether or not a TMY approach is appropriate is to ask whether or not these types of differences on P-values are acceptable for a given project. If P-values are being used to secure financing on Megawatt-scale projects, then the small added complexity involved in running a full time series will probably seem worth the effort! On the other hand, if a project is still at the pre-feasibility stage with inter-annual variability being relatively small compared to other uncertainties, then a TMY analysis will probably be good enough. Finally, while this study focused on the impact of TMY analysis on P-values, there can be other reasons for running a full time series analysis, for instance whenever there is a need to generate a realistic long-term time series of PV output power.

5. Acknowledgements

We would like to thank Mark Stoelinga, Gwendalyn Bender and William Gustafson for helpful feedback and suggestions.

6. References

Jordan, D.C. and Kurtz, S.R., 2013. Photovoltaic degradation rates – an analytical review. *Progress in Photovoltaics: Research and Applications*, Volume 21, Issue 1, 12–29.

PVsyst photovoltaic software website, <http://www.pvsyst.com/en>, accessed May 30, 2016.

Ryberg, D.S., Freeman, J., Blair, N., 2015. Quantifying Interannual Variability for Photovoltaic Systems in PVWatts, Technical Report NREL/TP-6A20-64880, available online at <http://www.nrel.gov/docs/fy16osti/64880.pdf>, accessed May 30, 2016.

Silverman, B.W., 1998. *Density Estimation for Statistics and Data Analysis*. Chapman & Hall/CRC, London, UK.

Vaisala, Vaisala 3TIER Services Global Solar Dataset/ Methodology and Validation, available online at <http://www.vaisala.com/en/energy/Documents/WEA-ERG-3TIER-Global%20Solar%20Validation.pdf>, accessed May 30, 2016.



Global Validation of REST2 Incorporated Into an Operational DNI and GHI Irradiance Model

William T. Gustafson¹, Gwendalyn Bender¹, Louise V. Leahy¹

¹ Vaisala Inc, Seattle WA 98121, USA

Abstract

Two categories of models can be used to predict direct normal irradiance (DNI) for solar concentration or tracking photovoltaic applications. The first type are broadband radiative models that predict DNI under clear skies from atmospheric data. The second are methods used to extract DNI from global horizontal irradiance (GHI). While many validation studies have been done on the latter the former have only been evaluated in localized studies of a dozen or fewer sites and those mostly in the USA [1,2]. We propose to do a global validation of the REST2 direct irradiance model at 100+ locations world wide against both GHI and DNI.

Keywords: *satellite dataset, irradiance modeling, REST2, Perez SUNY, GHI, DNI*

1. Introduction

We incorporated the REST2 clear sky model into our existing operational system for producing hourly time series of GHI, DNI and diffuse at a resolution of 2 arc minutes globally. This process also required incorporating the MERRA2 (Modern Era-retrospective Analysis for Research and Applications) datasets for turbidity and aerosol modeling. At independent ground stations with GHI and/or DNI measurements for a concurrent period of time we compared the REST2 derived irradiances to the measured irradiances to determine the bias, RMSE and MAE statistics between the two.

Further, at the same sites we compared GHI and/or DNI modeled on the SUNY Perez clear sky methodology[3], which derives DNI from clear sky GHI estimates. This process derives the turbidity and aerosol modeling from the MODIS dataset. Stations are as globally distributed as possible in order to represent a variety of climates, elevations, etc. The ground measurement data has been lightly quality controlled to ensure only high quality data is included.

Results are presented in tables and in maps such as in Fig. 3 below so readers can easily see the spatial differences. Due to file size limitations, only a sample of the maps we created are included in this manuscript.

2. Methods

2.1. Current processing methodology

We are following the basic methodology laid out by Richard Perez in his paper[3] modified with certain proprietary algorithms and various publicly available source data. We use a 2 arc-minute base resolution, processing various broad-band visible data from geosynchronous weather satellites to create cloud indexes (estimates of cloud cover and optical thickness). Currently GOES-13, GOES-15, Meteosat 7, Meteosat 10, and Himawari are processed daily, with historical data back to 1997-1999, depending on the region. Snow

cover data derived from National Ice Center dataset[4] is also used in the cloud index calculation. These cloud indexes are calculated using a proprietary algorithm.

Clear Sky Irradiance is calculated from Linke values using Perez methodology. Linke values are calculated using methodology from Ineichen's paper[5] with data MODIS daily Aerosol Optical Depth (AOD) and water vapor datasets, shown in Table I.

Cloud indexes calculated from raw weather satellite data and snow cover are used to modulate Clear Sky GHI to calculate GHI values. DNI values are calculated from GHI using Perez's modified DIRINT method[3]. Diffuse is calculated from GHI and DNI and the solar zenith angle. after. This process is illustrated in Fig.1.

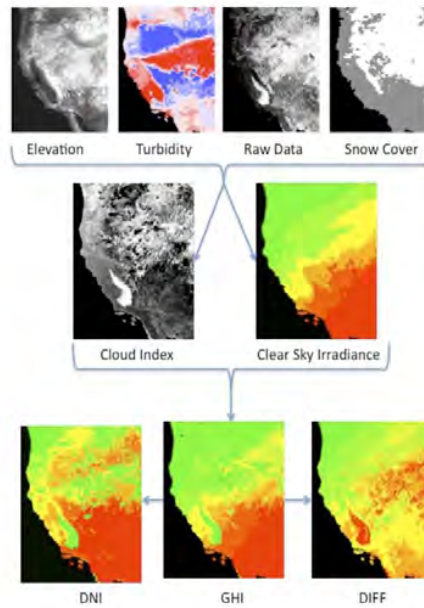

Fig. 1: Current processing methodology

2.2 Replacement of Perez Clear Sky Model with REST2 Clear Sky Model

The REST2 model is a parameterized version of Dr. Gueymard's SMARTS radiative transfer model. We are using a version of the code which uses the inputs listed in Table 1. Defaults are currently used for ozone, albedo, single scattering albedo and asymmetry parameter.

Tab. 1: INPUTS TO PEREZ-INEICHEN CLEAR SKY MODEL

Quantities	Source	Notes
AOD at 550 nm	MODIS	Spatial Res: 1.0 degree Temporal Res: daily
Precipitable Water (cm)	MODIS	Spatial Res: 1.0 degree Temporal Res: monthly

Tab. 2: INPUTS TO REST2 CLEAR SKY MODEL

Quantities	Source	Notes
Alpha (Angstrom Exponent),	MERRA2	Spatial Res: 0.5-0625 degree Temporal Res: 1 hours
AOD at 550 nm	MERRA2	Spatial Res: 0.5-0625 degree Temporal Res: 1 hours
Precipitable Water (cm)	MERRA2	Spatial Res: 0.5-0625 degree Temporal Res: 1 hours
Surface Pressure (pa)	MERRA2	Spatial Res: 0.5-0625 degree Temporal Res: 1 hours

MERRA2 inputs replace MODIS inputs, and directly feed REST2. Linke turbidity is not calculated. The REST2 calculation replaces Perez-Ineichen clear sky calculation.

In both models, GHI is calculated by modulating the cloud index values with the clear sky GHI values to calculate the GHI value. In the Perez model DNI is calculated from GHI using Dr Perez's DIRINT methodology. In the REST2 model a second modulation function is used to calculate DNI from the cloud index and the clear sky DNI value. Diffuse is then calculated from the GHI, DNI values and solar zenith angle.

These modulation functions vary regionally (and in some cases temporally) as the cloud index values have a dependence on the satellites being used to calculate them. These modulation functions are calculated for each region from a selected set of high-temporal resolution observations.

The fit is based on ground-observed GHI and calculated GHC, with $kt = GHI(obs) / GHC(calc)$. These kt values are then related to the satellite-based CI values. Once this relationship is established ($kt = f(CI)$), it is used to calculate GHI from satellite-based CI and calculated GHC. An example modulation function is shown in Fig. 2.

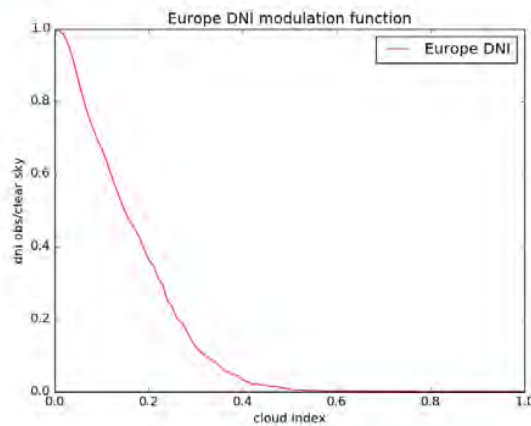

Fig. 2: DNI Modulation function for Europe

3. Observations From Ground Stations

For validation purposes we gathered GHI data from 186 publicly available ground stations plus 59 from clients who have authorized the release of their data. This covers 1689 station-years of observations. For DNI we have 158 public, and 2 private sites, covering 1165 station-years. The stations are independent of one another, and independent of the modeled output. Beyond the handful of stations used to create the modulation functions Vaisala does not allow local observations to affect our model, so that comparisons can be made site to site.

4. Validation

Overall Mean Bias Error (MBE), Root Mean Square Error (RMSE) and Mean Absolute Error (MAE) both absolute and as a percentage of Observed Mean are calculated. Our clients are typically most interested in low MBE to ensure that our resource estimates will be accurate, RMSE tests that residuals are not too large and looking at MAE ensures that we do not have bias errors that are canceling each other.

Figure 3 shows Perez based GHI percent bias error, while Figure 4 shows the same information for REST2 based GHI percent bias error. The more pastel the points are the closer they are to zero biased. Generally, REST2 data is closer to unbiased (e.g. Australia, South Africa) although there are exceptions (Saudi Arabia). Figure 5 shows Perez based DNI percent bias error, while Figure 6 shows the same information for REST2 based DNI percent bias error.

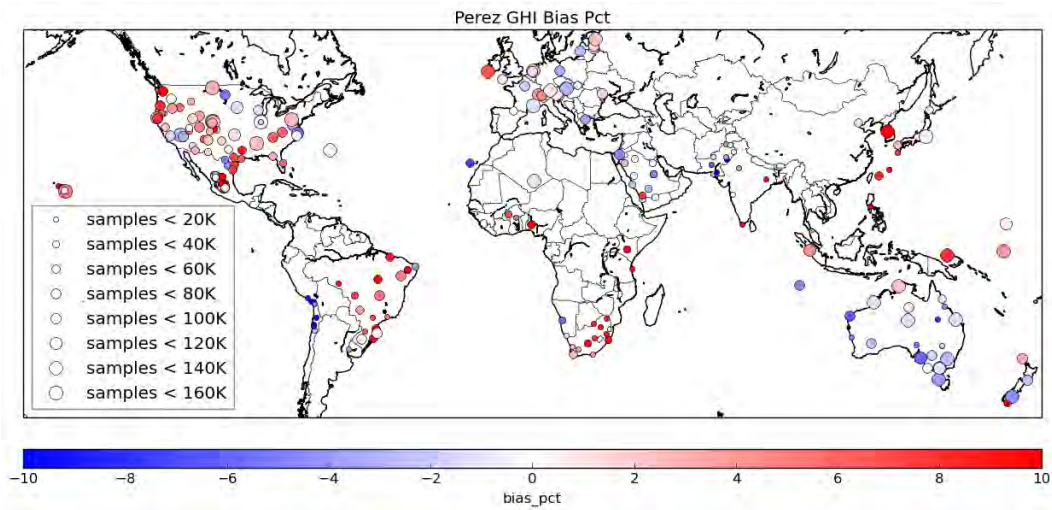

Fig. 3: GHI bias as percentage for Perez

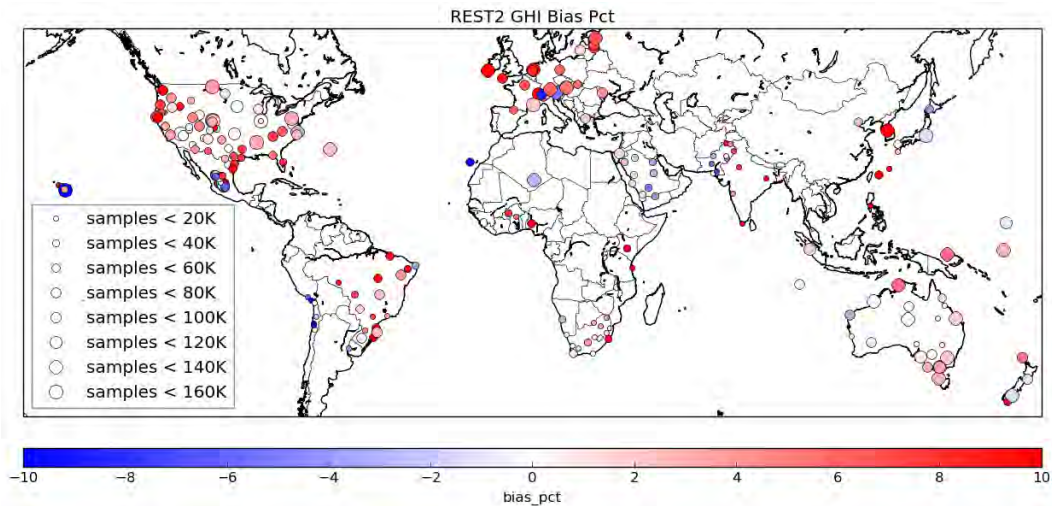

Fig. 4: GHI bias as percentage for REST2

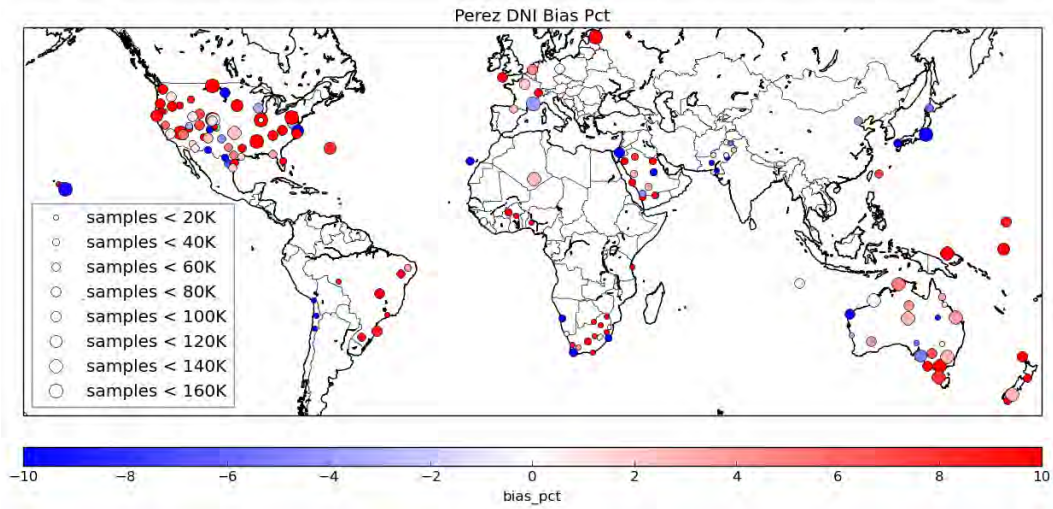

Fig. 5: DNI bias as percentage for Perez

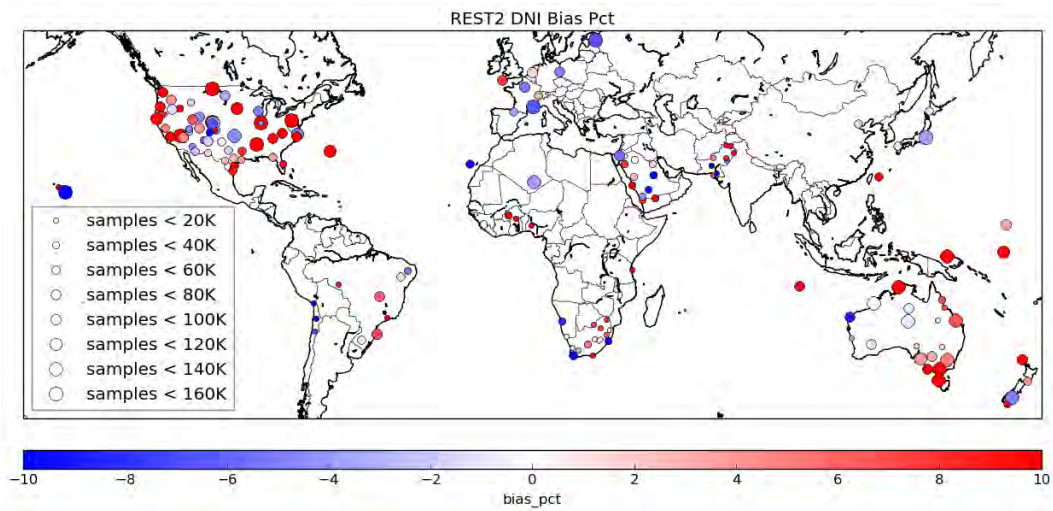

Fig. 6: DNI bias as percentage for REST2

Tables 3-6 show aggregate statistics of MBE, percent MBE, RMS, percent RMS, and MAE, percent MAE for REST2 and Perez GHI, and REST2 and Perez DNI respectively. The median values and 75th percentile values for all parameters show significant improvement from Perez to REST2.

Tab. 3: REST2 GHI AGGREGATE STATISTICS

REST2 GHI aggregate statistics (N=245)				
parameter	25%	mean	median	75%
MBE	0.99-	5.97	4.28	11.72
MBE Pct	0.46-	3.21	2.28	6.51
RMS	52.73	78.70	61.10	80.33
RMS Pct	23.77	38.14	31.17	44.31
MAE	22.67	38.08	28.42	39.62
MAE Pct	10.70	18.46	14.16	20.53

Tab. 4: PEREZ GHI AGGREGATE STATISTICS

Perez GHI aggregate statistics (N=245)				
parameter	25%	mean	median	75%
MBE	-2.76	6.53	3.60	12.77
MBE Pct	-1.31	2.97	1.83	5.92
RMS	54.78	80.00	64.46	80.80
RMS Pct	24.55	38.06	31.62	40.26
MAE	24.35	39.11	29.56	40.17
MAE Pct	11.36	18.60	14.58	20.11

Tab. 5: REST2 DNI AGGREGATE STATISTICS

REST2 DNI aggregate statistics (N=160)				
parameter	25%	mean	median	75%
MBE	7.23-	2.64	6.28	22.45
MBE Pct	3.59-	11.11	3.58	11.48
RMS	100.84	188.56	120.98	173.35
RMS Pct	47.65	86.56	63.89	88.65
MAE	43.14	79.49	51.02	68.80
MAE Pct	20.66	38.06	26.97	37.62

Tab. 6: PEREZ DNI AGGREGATE STATISTICS

Perez DNI aggregate statistics (N=160)				
parameter	25%	mean	median	75%
MBE	-8.16	4.56	8.21	29.63
MBE Pct	-3.34	11.33	3.66	13.67
RMS	107.59	197.25	132.18	176.88
RMS Pct	50.83	85.73	66.14	90.49
MAE	49.55	88.63	61.96	85.85
MAE Pct	23.70	40.69	30.98	41.33

Tables 7 and 8 show direct comparison statistics between Perez and REST2 for GHI and DNI. The tables show how many stations have better statistics for each parameter, and which ones tie within 1%. REST2 wins in every category.

Tab. 7: DIRECT GHI COMPARISON STATISTICS

GHI (N=245)			
parameter	REST2	Tie (1%)	Perez
MBE	144	16	92
MBE Pct	144	25	83
RMS	147	48	57
RMS Pct	149	61	42
MAE	162	40	50
MAE Pct	161	60	31

Tab. 8: DIRECT DNI COMPARISON STATISTICS

DNI (N=160)			
parameter	REST2	Tie (1%)	Perez
MBE	96	7	53
MBE Pct	93	17	46
RMS	115	10	31
RMS Pct	93	29	34
MAE	135	6	15
MAE Pct	130	17	9

5. Summary

This validation process will allow us to see how different methods of deriving GHI and DNI fare against independent ground station measurements. Our validation results may suggest that model performance varies regionally, or indeed, that one model is superior to the other across all regions included in the global validation study. This will provide the industry with information it can use to improve the accuracy of resource assessments, and therefore decrease the risk and uncertainty associated with large project developments.

6. References

- [1] Gueymard, Christian A. "REST2: high-performance solar radiation model for cloudless-sky irradiance, illuminance, and photosynthetically active radiation—validation with a benchmark dataset.", *Solar Energy*, vol. 82.3 pp. 272-285, 2008.
- [2] Sengupta, M., Habte, A., Gotseff, P., Weekley, A., Lopez, A., Anderberg, M., Molling, C. and Heidinger, A., "Physics-Based GOES Product for Use in NREL's National Solar Radiation Database." in *Preprint. Prepared for the European Photovoltaic Solar Energy Conference and Exhibition*, 2014.
- [3] Perez R, Ineichen P, Moore K, Kmiecik M, Chain C, George R, Vignola F. "A new operational model for satellite-derived irradiances: description and validation.", *Solar Energy*, vol. 73, pp. 307-17, 2002.
- [4] National Ice Center. 2008, updated daily. *IMS Daily Northern Hemisphere Snow and Ice Analysis at 1 km, 4 km, and 24 km Resolutions, Version 1. 1 km, 4 km, and 24 km*. Boulder, Colorado USA. NSIDC: National Snow and Ice Data Center. <http://dx.doi.org/10.7265/N52R3PMC>, 2016.

Renewable Energy Grid Integration



Some consequences to grid operation due to high penetration of distributed PV systems

Umnouy Ponsukcharoen¹ and Walter Murray¹

¹ Stanford University, Stanford CA (The United States)

Abstract

Traditional forms of power generation could on their own be the sole supplier of power. This is not true of PV, which raises the question of what the limits are and how best to operate and modify the grid to maximize the limits. Here we analyze distributed PV since it is the most problematic and currently has the fastest growth. We study bounds on limits to distributed PV based on its generation profile compared with the grid demand profile. We use data collected over two years from two postal codes, one in New Jersey and one in California.

Keywords: *distributed PV generation, daily maximum PV power curves*

1. Introduction

We concern ourselves with residential PV, which is the fastest growing sector (SEIA, 2014) due in part to the fact it does not face protracted planning permission. The ideas presented are easily extended to other sectors. PV suffers from variation due to time of the year, time of the day, environment and weather. It is the later that causes the great concern since it makes PV generation volatile. The great virtue of the current means of generation is its enormous inertia, which in turn makes dynamical issues rare. High volatility clearly makes matching demand to generation hard.

As noted PV cannot in itself be the only form of generation. We address the issue of what the maximum possible limit is to the penetration of PV. We deal only with residential PV but the ideas we present can be extended to commercial sites and sites operated by the utility. The hard case is caused by distributed PV. Right now almost anyone who wants to install a system may do so. A point may be reached where permission may be withheld or come with restrictions. We investigate where that point may be. Our primary tool is to extrapolate the generation of PV and see when a point is reached where it exceeds demand. That gives an upper bound. However, that bound would be lowered by any amount a utility was not prepared to turn off such as their own PV systems. Surplus power could be stored but doing so raises the cost of PV as does the inability to sell surplus generation.

To determine when PV generation exceeds demand we need to model current generation and extrapolate. To do that we need a maximum power curve for each day of the year. One means of doing that for a set of PV installations is analyzing the features of the installations along with the irradiation at the locations. This is complex and to be done accurately would need to take into account shadows, state of the systems, etc. Also it is constantly changing as more installations are made. We call this a structural approach. Modeling platforms by PVMPC (Hansen et al., 2014) and PVSyst may be used to compute the PV power output from quite a number of inconstant inputs. Estimates of the maximum penetration limit from various studies (Lopez et al.,

2012; Energy and Inc. Environmental Economics, 2012) relies on this approach. We propose a reduced-form approach for constructing maximum PV power curves, which describes the maximum power from a group of PV systems at any time instance. To generate such a curve we use the *output* of a sample set of systems. Since this sample is fixed regardless of how many systems are installed this is a manageable set of information for the grid operator to collect. We first define and validate the concept of a normalized power curve, which is needed to construct a maximum power curve. We then construct a maximum power curve from a normalized power curve for a group of PV systems in two different geographical areas. Finally, we illustrate how to use the maximum power curve of a group of PV systems in two applications: constructing the expected PV power curve finding the maximum PV penetration limit.

An obvious issue is the size of sample and how that can be used to meet the required accuracy. We analyzed the impact of varying sample size and showed that for California 50 sites was sufficient and that New Jersey required 100 sites. The reason the sample is so small is the generation for two sites is highly correlated. We expect sample size will vary a little with the area over which the sites are distributed and with the variability of the weather between locations of sets of sites.

2. Data

2.1 Data set

The time series of power outputs from 2 groups of PV systems were collected at a 15-minute frequency by a solar PV monitoring company. Each time series of a PV system starts on either January 1st, 2014 or on its installation date. The locations of the PV systems in each group are from the same zip code. A grid operator's perspective may prefer a group of PV systems linked to the same substation rather than the same zip code. Still we assume the same characteristics. We name the 2 data sets as 'CA' for the group in one particular zip code of California, and 'NJ' for the group in New Jersey. The installed capacity of each PV system is reported as a range of 0-1 kW, 1-2 kW, 2-3 kW, 3-5 kW, 5-10 kW, 10-20 kW, 20-50 kW, 50-100 kW, or 'NaN' since the exact installed capacity is confidential.

2.2 Data cleaning

In order to construct normalized maximum power curves correctly in an organized manner, we clean data by first removing data from systems with an installed capacity greater than 20 kW as we are only interested in residential-size PV systems. Each time stamp in the time series is adjusted so that it ends with 00:00, 15:00, 30:00, or 45:00.

2.3 Installed Capacity Estimates

In order to define a normalized power curve, the installed capacity of each PV individual system should be known. However, due to confidentiality this information is not available. Instead, the installed capacity of a PV system is given as a range. If we assume that the installed capacity is uniformly distributed in a range, then we can estimate any installed capacities in the range to be equal to the midpoint of the range. We still aggregate data from several sites so it is not necessary for the data from a specific site be known accurately.

In order to find a better estimate of the installed capacity, we investigated other sources of data where information about the installed capacities of PV systems is available. NREL's Open PV project has a data set of installed capacities of PV systems over time and region. Figure 1 shows histograms of installed capacities of PV systems in California and New Jersey from 2008 and 2015.

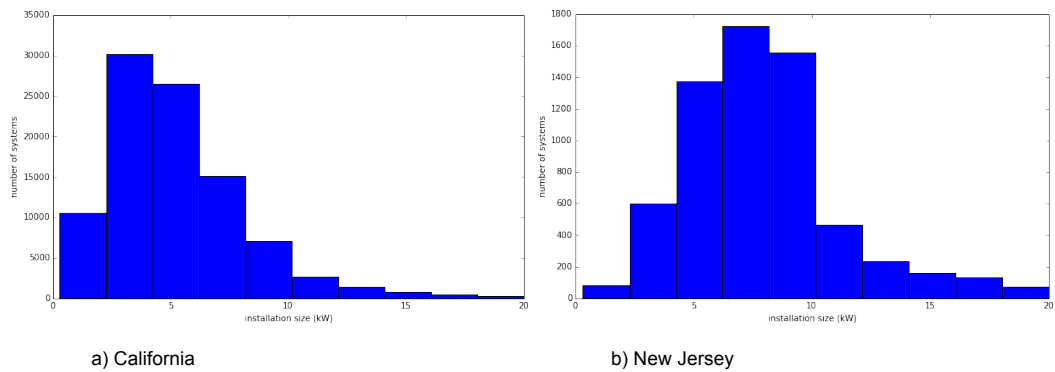

Fig. 1: Histograms of installed capacities up to 20 kW in 2008-2015 from NREL's Open PV project

From the data in this histogram, we computed the mean value in each bin and use it as an estimate for the installed capacity in our data set. We show in Section 3.1 that this estimate is better than using the midpoint of the range.

3. Methods and results

3.1 Definition and validation the concept of a normalized power curve

A normalized power curve for a group of PV systems is defined at each time instance as the total power from the group divided by its total installed capacity. The notion of normalization is important because scalability by the capacity of the PV installation is an essential feature of a maximum power curve model. The current PV generation capacity is low compared to both the total load and the potential for new PV installations. Consequently, it is possible that the maximum power curve for a current group of current PV systems may not be applicable to a system with high PV penetration. Hence, we establishes the consistency in defining a normalized power curve. With this normalized power curve, we can scale it in order to estimate future limitations on the capacity of PV installations.

To ensure that the definition of a normalized power curve is consistent, we first demonstrate that the power generated by a group of PV systems is proportional to its total installed capacity. We compute time series of the mean power by the number of systems from PV systems with a size of 5-10 kW and another time series from PV systems with a size of 10-20 kW. The scatter plot of the mean power from two groups as shown in Figure 2 shows proportional relationships from both 'CA' and 'NJ' data sets. The slopes of the relationships match the ratios of ratio of our installed capacity estimates for PV systems in a 5-10 kW bin and a 10-20 kW bin from Open PV project data rather than the estimates from the midpoints of the bins. This means the estimates from Open PV project is better than the estimates from the midpoints of the bin.

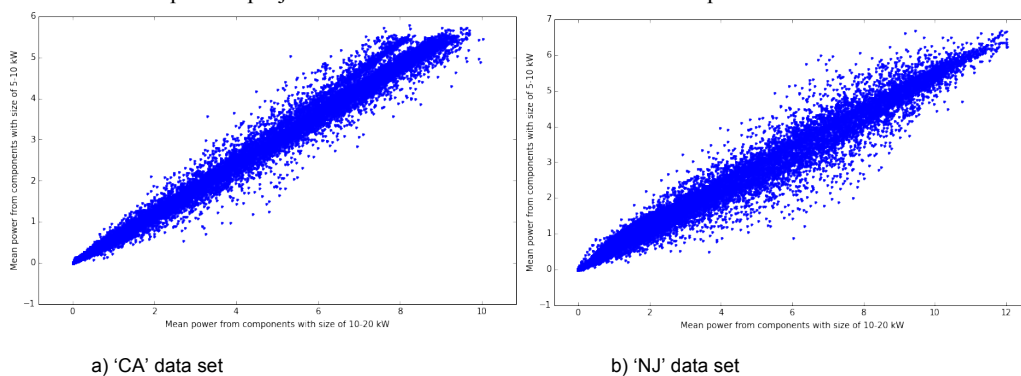

Fig. 2: Scatter plots of the mean power by PV systems from 2 bins: 10-20 kW and 5-10 kW

Next we observed that the deviation of energy generation from a group of PV systems from different years of data collection is small. For 2013 and 2014 it is about 1-2%. We confirmed that the deviation of energy generation of groups of PV systems with different installation dates is also acceptable. The deviation of yearly energy generation from a group of PV systems installed in different quarters of 2013 is about 4-8%.

We identified a sufficiently large number of PV systems for consistent normalized power curves. As shown in the Figure 3, the average absolute deviation in yearly energy generations decreases as the number of PV systems increases. We need only 49 systems to achieve a deviation of less than 1 percent for the 'CA' data set while we need 100 systems to obtain the deviation of less than 1 percent for the 'NJ' data set.

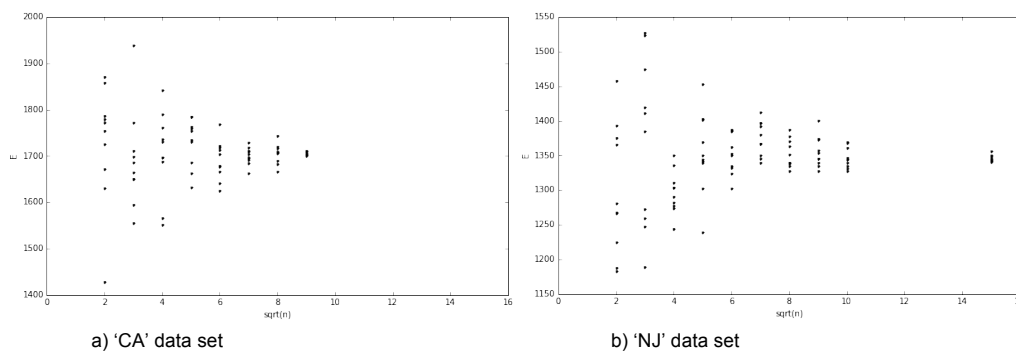

Fig. 3: Yearly energy generations derived from a different number of PV systems. Each number has 10 samples. The horizontal axis shows the square root of the number of PV systems

Resulting from these consistency checks, the heuristics to produce consistent normalized power curves is:

1. Clean the data so that time series of power outputs from PV systems are aligned. Make sure that the installed capacity of each PV system is known or well estimated.
2. Determine a point on a normalized power curve by summing all power outputs and dividing them by the sum of installed capacities associated with the power readings at that instance. As a rule of thumb, the number of PV systems should be at least 50
3. Check if there is a need to distinguish data from different years of collection or from PV systems with various installation dates. However, due to a limited amount of data, we may treat them equally and accept a possible deviation of about 4-8%.

3.2 Construction of a normalized maximum power curve

To get an insight of how to construct a normalized maximum power curve for every day in a year, we first consider several daily normalized power curves generated from the 'CA' data set and the 'NJ' data set using heuristics described in the previous section. Some examples are shown in Figure 4 and 5. We found some daily normalized power curves that resembles a simple bell shape with a high daily energy generation relative to neighboring days. This leads to an idea that we may model these well-behaved power curves (Figure 4), which are likely to be the maximum normalized power curves, and interpolate models to all the remaining days in a year. A function that models maximum normalized power curves should be non-negative and similar to a bell shape with the domain of time interval between sun rise and sun set.

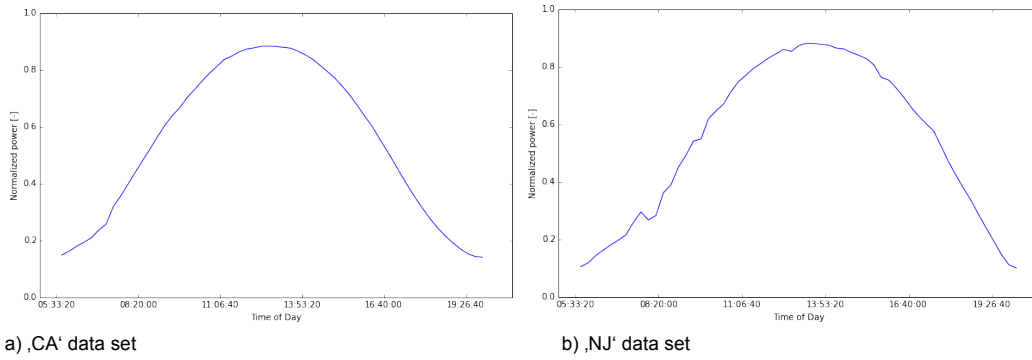

Fig 4: Well-behaved daily normalized power curves on 2014/6/24

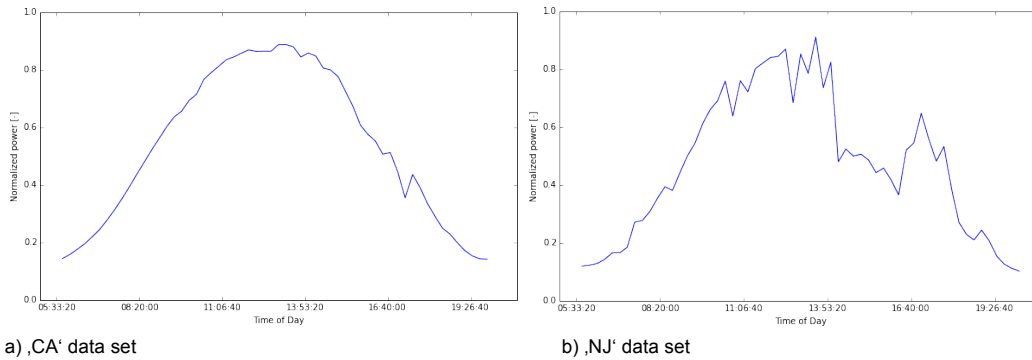

Fig 5: Typical daily normalized curves on 2014/6/21

In order to construct models to neighboring days in which the sun rises and sets at different times, we transform the domain of daily power curves so that they are common to all days. We define s as a negative cosine of an angle on a facial plane of an observer facing the south. Such a value can be computed from

$$s = \frac{y}{\sqrt{y^2 + z^2}} \quad (\text{eq. 1})$$

, where (x,y,z) is a cartesian coordinate of the sun in which the positive x -axis points to the south and the positive y -axis points to the east. With this transformation $s = -1$ corresponds to a sun rise and $s = 1$ corresponds to a sun set.

Next, we automate the selection of well-behaved power curve selection. In the first stage, we perform regression on each daily normalized power curve and filter out the power curves that either fit poorly (R -squared < 0.95) or has more than one critical point. In the second stage, we filter out the power curves that have significantly low daily energy generations relative to the neighboring days. In order to do such a task, we transform the plot of daily energy generations of all daily powers that pass the first stage (Figure 6) into a plot against a variable called Day Before a Winter Solstice (DBW) a single year window (Figure 7). The DBW for each day is defined such that DBW for a Winter Solstice of each year is zero and DBW for any other day is negative integers up to -365 . From Figure 7 to Figure 8, we remove a point below the envelope if there exists a higher point in the plot such that the line segment connecting them has a slope higher than a threshold. Daily power curves associated with remaining points in Figure xx are claimed as well-behaved power curves.

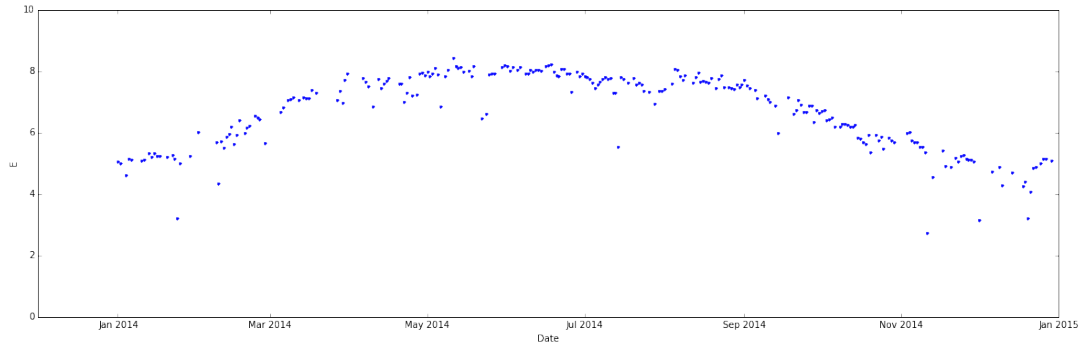

a) 'CA' data set

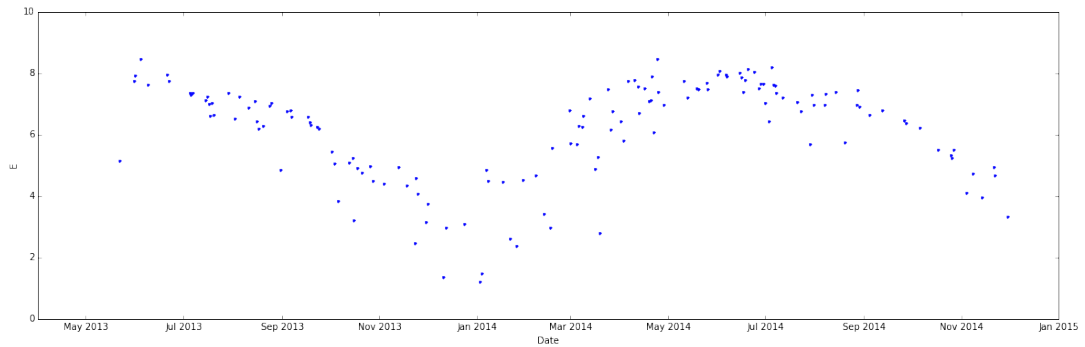

b) 'NJ' data set

Fig 6: The daily energy generations of all daily power curves that pass the 1st stage.

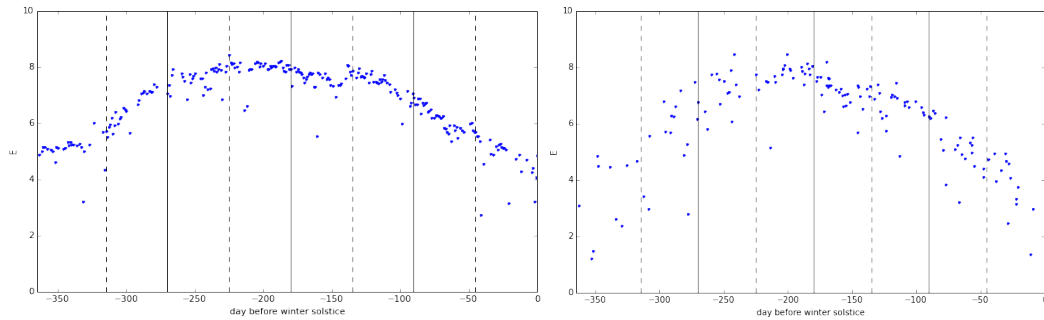

a) 'CA' data set

b) 'NJ' data set

Fig 7: The daily generations of daily power curves that pass the 1st stage with a new variable DBW and overlay.

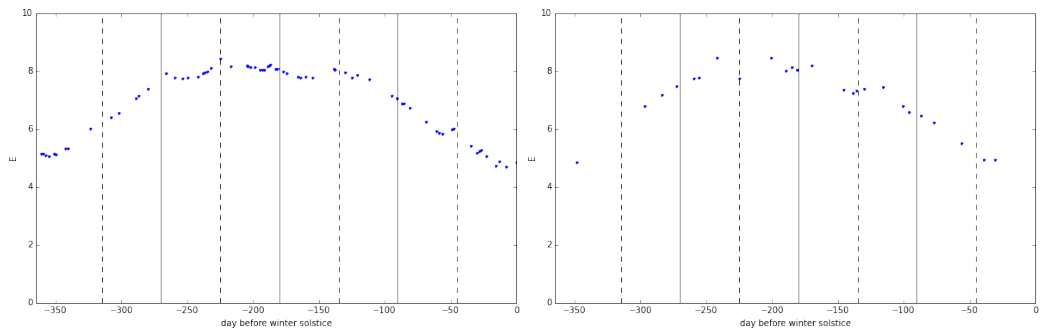

a) 'CA' data set

b) 'NJ' data set

Fig 8: The daily generations of daily power curves that pass the 2nd stage with a new variable DBW and overlay.

4.1 Expected PV power curves

An expected power curves is defined as a graphical illustration of an average power output from a group of PV system over a day. The expected PV power curve should reflect a PV power's variability but not volatility. Such a curve is useful in a day-ahead planning as the grid operator needs to supplement extra energy generation to match the demand. A simple expected PV power curve can be constructed by scaling a maximum PV power curve by a factor. A suitable factor is the mean of performance ratios in a year. One can refine the expected PV power curve by scaling each part of the maximum PV power curve with a different factor depends on a time of a day and a day of a year. Such a factor is the mean of performance ratios in a bucket of (s, DBW) pairs. With a simple linear interpolation and periodic boundary conditions, we generate a continuous function of the scaling factor and multiply it with the maximum power curve to obtain the expected PV power curve. Figure 12 shows examples of daily expected power curves (green) in a comparison with maximum power curves (red) and actual power curves (blue).

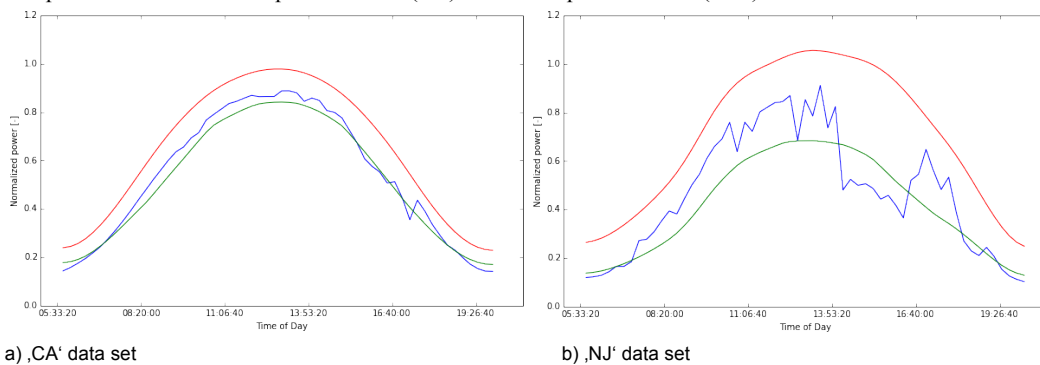

Fig 12: Typical daily normalized curves and expected power curves on 2014/6/21

4.2 Finding the maximum penetration limit

We define the maximum penetration limit to be the maximum generation such that at no point is supply greater than demand. Here the whole grid is assume to have no storage capacity. On the other hand, the grid operator can transfer the power from one point to another in the grid without any constraints. All PV systems in the grid behaves similar to normalized power curves from our sample PV systems.

It implies that, if the ideal generation of PV systems is assumed, the maximum installed capacity is equal to the minimum of ratios between the load curves and the normalized maximum power curves over a year. In the case of realistic generation, however, the maximum installed capacity is equal to the minimum of ratios between the load curves and the normalized expected power curves over a year. The numerical values of contribution from PV generation are summarized in Table 1.

Tab. 1: A contribution of PV to annual peak load and annual demand in 2014

Quantities	CAISO	PJM
% Peak load (GW)	29 (at 5:00 pm August 1 st)	26 (at 6:00 pm June 17 th)
% Demand	28	24

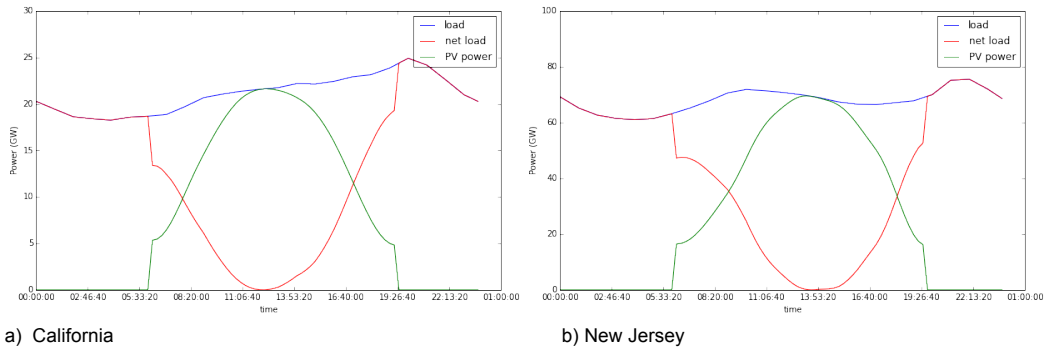

Fig 13: Load, PV power and the net load curves under the maximum penetration limit on 2014/4/20

Recall this assumes we have the maximum PV generation. Obviously the real contribution will be smaller. On average the real contribution for CASIO is about 80% and for PJM 55%. Note that the behavior of PV generation near sun rise and sun set is problematic to extrapolate but plays no role in determining PV limits. Surprisingly the critical day for both Cal data and the NJ data was the same despite the disparity in locations. However, the critical time in the day is significantly different due to the NJ profile although being similar to CA has an additional dip in demand. We had envisaged that each zone would require its own analysis but it could be the differences are sufficiently close that a good enough global solution can be obtained.

We have made a number of assumptions the most obvious of which is assuming that we have perfect weather. The limit could be raised by applying the same methodology, but using daily normalized expected generation curves (see Fig 12). To match the normalized maximum power curves means raising installation in California about 25% and in New Jersey about 80%. Such curves lead to a very similar contribution to the grid as using the maximum power curve. However, there will be a 50% probability of either exceeding or not meeting load at the critical point and a significant probability elsewhere. As a consequence it is highly likely the contribution to the grid will be lower than the figures for the maximum power curve. When we have a bad weather day we are below the expectation but when it is a good day we do not get the full benefit if we exceed the load. For real generation the outlook is bleaker since volatility will exacerbate both the degree of mismatching load and the frequency it arises.

A serious cause for concern is the rapidly changing generation the utility now has to provide. Note this is not caused by volatility but from giving preference to generation from distributed PV. Almost all other considerations such as the assumption of being able to transport energy to any part of the grid will lower the limit. The exception is storage but this has financial implications and also physical limits on how fast it can absorb and release power. Raising the PV curve in fig xx above demand by a small amount would not be an issue but anything significant raises the rate surplus power needs to be absorbed and released. All this would be exacerbated by the volatility of PV.

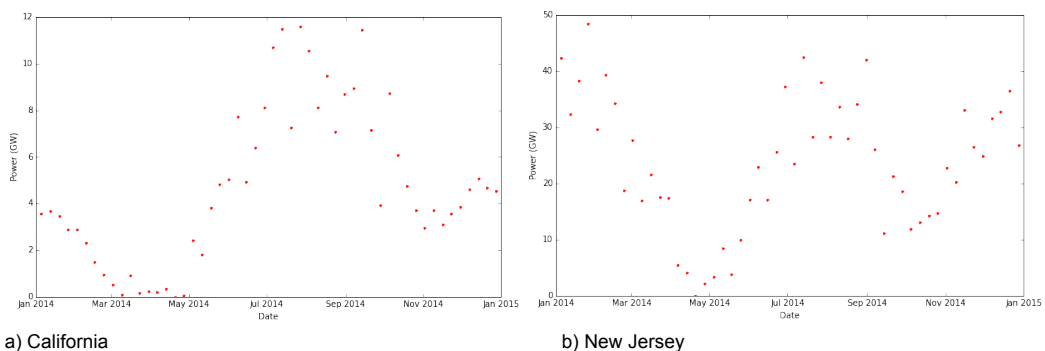

Fig 14: The minimum net load for Sundays in 2014

5. Conclusion

By analyzing extensive residential PV generation data from two disparate zones we were able to construct scalable models of the growth of residential PV contribution to the grid. We then assumed we have perfect circumstances for PV generation and determined the point at which PV generation exceeds load. At such a point the utility has to shut down all its generation. Growth of PV installations beyond this point implies that there will be progressively less generation as a percentage of installation

It is unlikely a utility will decrease generation to accommodate distributed PV generation to the point that we computed the limit. Any PV generation the utility owns is similar in behavior to distributed PV and as such reduces the level that distributed PV is attractive. Other utility renewal generation will also have priority along with base load generators such as nuclear power. PV generation distorts the load profile that other generation needs to match. Rather than flattening the load it distorts it further from the ideal of a flat line. This is not something that can be addressed easily by suitable pricing models. Making electricity very cheap from 11am to 1pm would undermine the financial benefit of distributed PV to the home owner. The great hope would be storage but it would need in total to be utility scale and be able to have fast charge and discharge capability.

6. References

- Solar Energy Industry Association (SEIA), 2014. Solar Market Insight report 2014 Q4. <http://www.seia.org/research-resources/solar-market-insight-report-2014-q4>
- Anthony Lopez et al., 2012. US Renewable Energy Potential Analysis: A GIS-based analysis, NREL technical report. <http://www.nrel.gov/docs/fy12osti/51946.pdf>
- Energy and Inc. Environmental Economics, 2012. Technical Potential for Local distributed Photovoltaics in California <http://www.cpuc.ca.gov/NR/rdonlyres/8A822C08-A56C-4674-A5D2-099E48B41160/0/LDPV PotentialReportMarch2012.pdf>
- Clifford Hansen, Robert W. Andrews, Joshua S. Stein and Daniel Riley, 2014. Introduction to the open source pv lib for python photovoltaic system modeling package. Sandia National Laboratories.
- PVsyst SA. Pvsyst photovoltaic software. <http://www.pvsyst.com/en/>
- Open PV project. National Renewable Energy Laboratory. <https://openpv.nrel.gov/>



Assessing demand impact of solar capacity growth in Philadelphia

Joseph Ranalli¹, Mesude Bayrakci Boz², Kirby Calvert³ and Jeffrey R.S. Brownson²

¹ Penn State Hazleton, Hazleton, PA

² Penn State University, University Park, PA

³ University of Guelph, Guelph, Ontario (Canada)

Abstract

SolarPVAnalyst 2.0 is a tool, currently under development, that supports spatial decision making related to solar energy. This paper demonstrates a case study of SolarPVAnalyst 2.0, applied to assesses the impacts of PV siting and capacity growth on regional utility loads. In the absence of large-scale storage or other alternative forms of mediation, increased PV capacity is expected to lead to rapid changes in load that will require rapid response from traditional generation, and have been cited as an obstacle to successful growth of distributed rooftop solar generation. Rooftop segments identified by SolarPVAnalyst 2.0 were used to simulate deployment of PV installations throughout the city of Philadelphia. The installations were categorized by their approximate azimuth and tilt. Different solar growth strategies emphasizing a mix of solar deployment distributed among the cardinal directions azimuth groups were compared with regard to their impact on the regional net electricity demand, and load ramp rates throughout the year. Similar analyses enabled by SolarPVAnalyst could be used to predict the degree of challenge that increased growth of solar capacity poses to utility operation, and to create strategies to encourage development (e.g. through the use of targeted incentives) that could favorably mitigate the net demand impacts. Analyses can be multi-scalar, by examining spatially explicit load profiles at the city scale, neighborhood scale, or at the scale of an individual sub-station.

Keywords: *duck curve, spatially-resolved analysis, GIS, urban rooftop PV*

1. Introduction

As renewable energy deployment expands throughout the United States, a variety of energy stakeholders will experience a rising need for analysis tools to assist with decision making. These stakeholders include grid operators, urban planners, policy makers, and government agencies to name only a few. Many decisions made by these stakeholders will require analyses that can be conducted on a variety of spatial and temporal scales. For example, a single rooftop PV array may have a negligible impact on grid operations, but broad adoption throughout a region may produce significant aggregate effects. As such, tools are needed to support these analyses, allowing decision makers to investigate operations on scales from rooftop to city to region. A spatial decision making tool, SolarPVAnalyst 2.0, is currently under development to meet this need.

SolarPVAnalyst 2.0 integrates solar modelling with Geographic Information System (GIS) information to display data to users via a mapping interface. The solar modelling is provided using the System Advisor Model (SAM) Simulation Core (National Renewable Energy Lab, 2014). Initial development has targeted ArcGIS as a platform to provide a spatial interface. While development is still ongoing, this paper presents a case study of the data analysis potential of this tool for rooftop solar in the City of Philadelphia.

2. Background

The case study analysis investigated in this paper considers the impacts of wide-scale solar deployment in the City of Philadelphia on net loads at a utility scale. As renewable penetration increases, increased impacts are expected on the electrical grid. The famously titled “Duck Curve” phenomenon describes the rapid daily swings in net load resulting from expected solar generation growth in California. In the case of California, overgeneration has the potential to result in both economic and reliability challenges (Lew et al., 2015). Some of these challenges can be met by accounting for the variability of renewables as an intrinsic part of the grid

planning and operations (Denholm et al., 2015). A variety of strategies have also been proposed to mitigate these effects and to allow continued exploitation of solar energy opportunities, while maintaining grid stability. Schwartz et al. (2012) recommend that renewable siting be planned such that generation coincides with utility load profiles. Lazar (2016) specifically identifies orienting solar toward the west as a potential strategy for ameliorating high net load ramp rates, among other strategies such as strategically locating storage facilities and aggressive demand-side management. In this case study, we will consider the ability of deployment strategies based on array azimuth, as proposed by Lazar, to reduce ramp rates with high levels of solar PV deployment. Analysis of these types of strategies is an ideal application for a solar modelling tool with spatially-resolved capabilities.

As a demonstration, in order to estimate the effects of solar development on the net electric load, solar PV systems were modelled on each available rooftop segment within the City of Philadelphia. An automated procedure was used to identify rooftop segments based on Light Detection and Ranging (LIDAR) data, using a technique adapted from Bayrakci Boz et al. (2015). The workflow of the rooftop extraction model is shown in Figure 1.

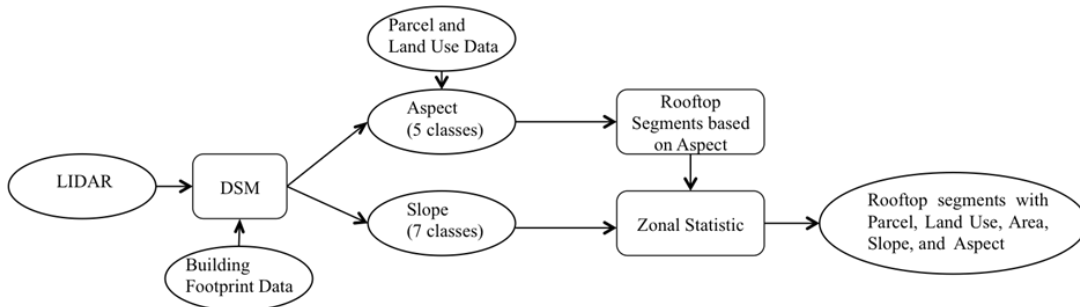

Fig. 1: Workflow of the ArcGIS model

Two key parameters are considered: slope(tilt) and aspect(azimuth). All geo-processing steps were conducted within the ArcGIS environment. Slope and aspect layers were created from the Digital Surface Model (DSM) using LIDAR dataset. First, the aspect (azimuth) layer were classified into five azimuth bins representing the four cardinal directions along with “flat” rooftops. Next, the slope layer was divided into seven classes, the first class representing flat roof. All rooftops with measured slope less than 10° were assumed to be flat. If the slope was greater than 60 degrees, the polygon was eliminated since it is not ideal for PV rooftop panels. Slope layer was grouped into 10° bins (e.g. 10° - 20°) with the midpoint used for analysis. Finally, rooftop segments were created based on aspect and slope for these segments were calculated using zonal statistic. Additionally, parcel numbers and land usage information were added. A summary of the rooftops identified in Philadelphia using this procedure is presented in Table 1.

Tab. 1: Rooftop segments identified by the LIDAR technique

Bin	Tilt Range	Aspect Range	# Surfaces	Area (m ²)	Avg. Area per Surface (m ²)
Flat	<10°	Any	836,581	27,236,240	32.6
North	10°-60°	315° - 45°	121,357	4,466,487	36.8
East	10°-60°	45° - 135°	79,479	3,314,164	41.7
South	10°-60°	135° - 225°	78,032	3,385,850	43.4
West	10°-60°	225° - 315°	78,871	3,364,420	42.7
TOTAL			1,194,320	41,767,161	35.0 (avg)

Load data for PECO (the utility serving Philadelphia) was obtained from PJM (PJM, 2016), the Regional Transmission Organization serving the region including Philadelphia. Hourly load data for 2014 were used to compute the average daily load for each month from that year. PV systems were modelled on each rooftop using SAM, with average daily AC production for each month serving as an output. Array wiring was computed by stringing together modules, but remaining within the chosen inverter string voltage rating. Complete systems were then sized by generating an integer number of strings capable of maximally filling the rooftop area. The inverter capacity was sized to be 15% greater than the DC rated capacity of the resultant

array. Typical Meteorological Year (Wilcox, 2012) data for Philadelphia was used to represent the solar resource. A workflow of this process is shown in Figure 2.

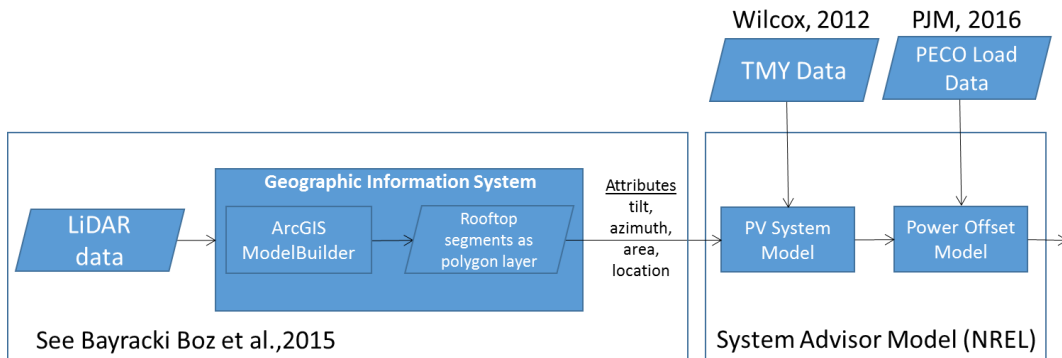

Fig. 2: Workflow of the process for computing net utility load

3. Results

The total theoretical energy production potential, accounting for all modelled systems, is estimated to be as much as 19% of the total PECO demand (i.e., 42,000,000 MWh/year). The total energy results for systems modelled in each direction are summarized in Table 2. Flat rooftops account for the largest amount of energy, in that they consist of approximately 6 times as much surface area as rooftops facing any other direction. To compare the bins directly, we compute the annual AC per unit system area, with results coinciding closely with expectations based on incidence angle effects. Flat, east- and west-facing systems produce about the same amount of energy per unit area, while north-facing systems underperform and south-facing systems perform above this mark.

Tab. 2: Annual energy produced by each azimuth bin

Bin	Tilt Range	Aspect Modelled	Area (m ²)	Annual AC (MWh)	Ann AC/area (kWh/m ²)
Flat	<10°	Any	27,236,240	5,170,000	190
North	10°-60°	0°	4,466,487	577,000	129
East	10°-60°	90°	3,314,164	596,000	180
South	10°-60°	180°	3,385,850	743,000	219
West	10°-60°	270°	3,364,420	602,000	179
TOTAL			41,767,161	7,688,000	179 (avg)

The month-by-month loads can be best visualized as a contour plot, shown in Figure 3. The minimum loads occur overnight, with fall and spring having relatively light loads. Winter is characterized by morning (~10AM) and evening (~7PM) peaks, while summer is characterized by a very large peak that lasts afternoon into evening. Interestingly, the ramp rates appear to be relatively constant throughout the year as shown in Figure 4. This indicates that although the absolute loads may increase or decrease throughout the year, the rate at which changes in load must be accommodated does not.

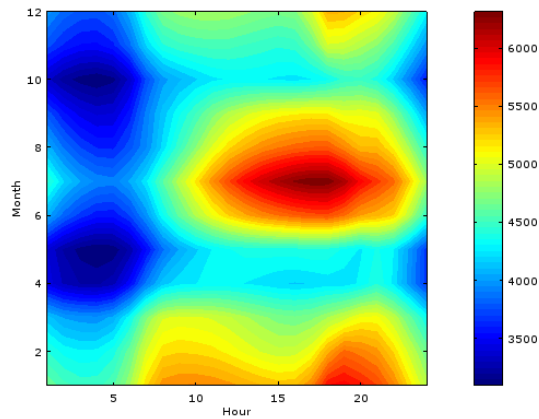

Fig. 3: PECO 2014 average daily loads by month. Color axis units are MWh.

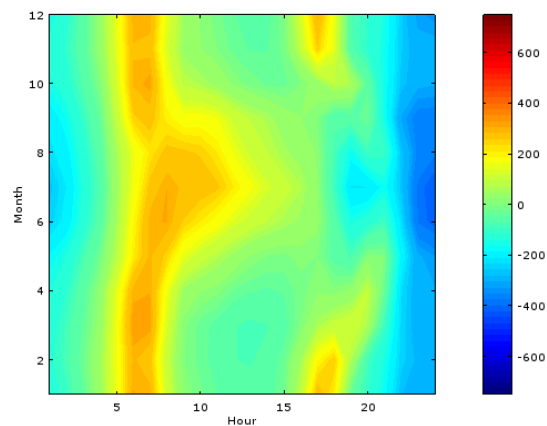

Fig. 4: Ramp rates for PECO 2014 average daily loads by month. Color axis units are MWh per hour.

When investigating the effect of solar on the known loads, we considered the variation associated with collectors in each of the azimuth bins. Figure 5 shows the daily variations in energy density for collectors facing each direction. Flat, north and south collectors all produce with approximately the same daily shape, with north-facing collectors having a much lower energy density. East-facing collectors favor morning production, resulting in steep-sloping morning ramp rate with a shallow evening. West-facing collectors favor evening production and follow an opposite trend; their morning production ramps up slowly, while dropping off quickly in evening. These variations have implications on the use of collector orientation as a strategy for mitigation of duck curve ramp rate effects.

In addition to favoring collector cardinal direction, an additional strategy was investigated. Figure 6 shows a comparison of south-facing collectors with a scaled mix of east and west (E&W) facing collectors. Scaling was achieved by requiring that the annual energy produced by south facing collectors match that produced by the E&W combination. While winter is similar between both strategies, it is evident that the E&W combination results in broadened production both toward morning and evening in spring and summer, with reductions in the midday peak. This may be advantageous in attempting to reduce the morning and evening ramp rates exhibited by the duck curve.

We can directly compare the effect of different solar deployment strategies on ramp rates. Figure 7 shows the average ramp rates throughout the entire year for each of the solar strategies. The effects seen on this average graph are similar to those observed when viewing individual months. As compared to the “real” orientation case, using the mixture of E&W deployment strategy mitigates the morning and evening ramp rates slightly. East-only and west-only cases provide different advantages; east-only reduces the evening ramp rate for most cases, but at the expense of increases in the morning ramp rate, while west-only has the opposite effect. The increase in evening ramp rate for west-only case is significant. We can compare the effects on a month-by-month basis looking contour plots of the net-load ramp rate for each of the strategies, as shown in Figure 8.

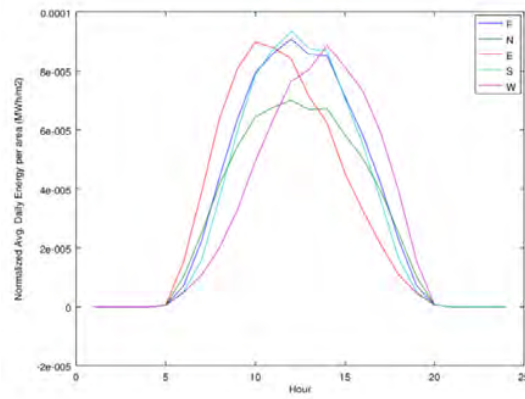

Fig. 5: Daily AC production per collector area for each of the collector azimuth bins.

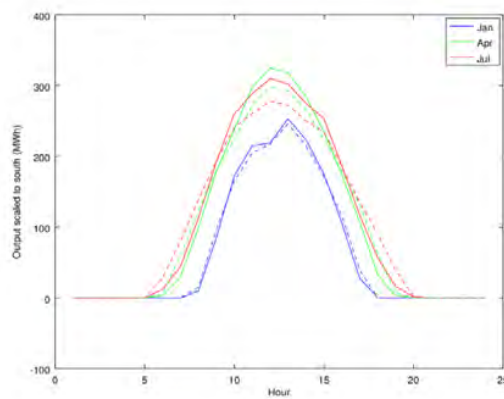

Fig. 6: Comparison of south (solid) and E&W-facing (dashed) collector orientation strategies for three months

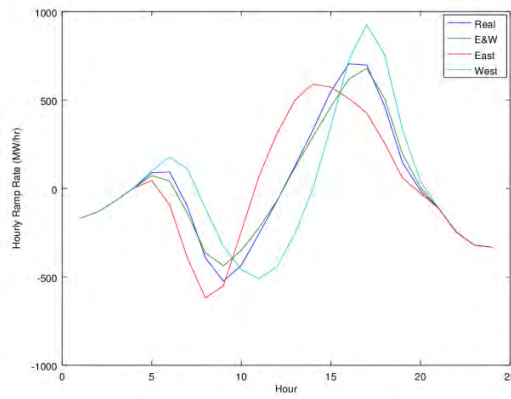

Fig. 7: Average daily ramp rates for each of the solar strategies.

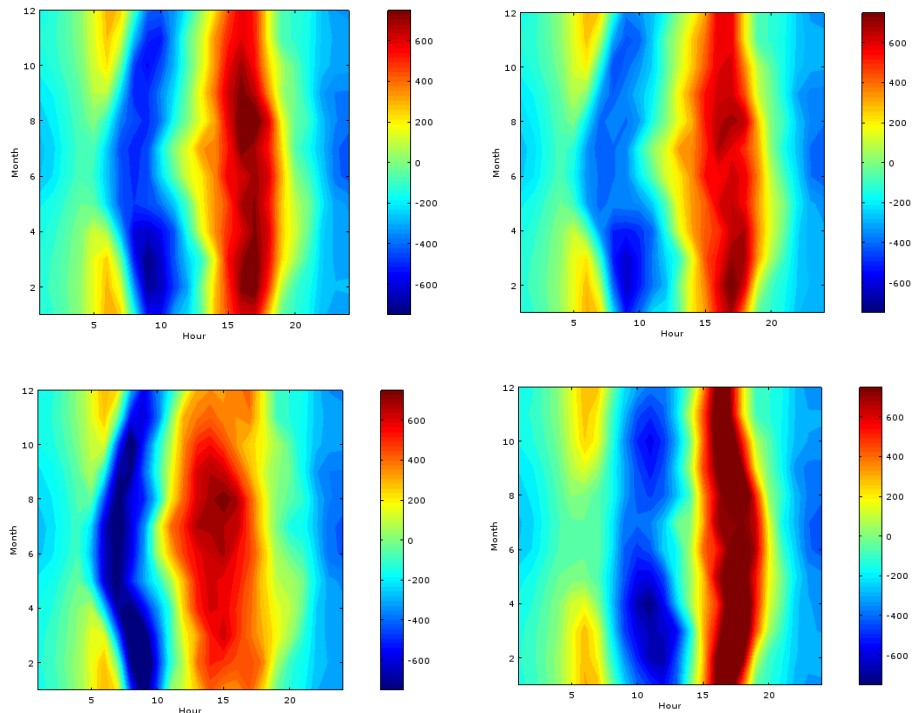

Fig. 8: Comparison of ramp rates for different solar strategies, all scaled to match the real orientation output level. (Top Left)-Real rooftop orientations, (Top Right)-E & W scaled, (Bottom Left)-East only, (Bottom Right)-West Only

Considering these results, it appears that for the City of Philadelphia, when installing solar on 100% of rooftops, only the E&W and east-only strategies provide observable benefits as compared to the natural orientations of the rooftops. While it is possible that other strategies demonstrate benefits at lower rates of solar adoption and at different scales (e.g., at the sub-station level), the present results indicate that promoting the dominance of west-facing solar has the effect of increasing the afternoon ramp rate while providing very little benefit in the morning, outside of shifting the ramp rate peak to later hours. Use of an E&W combination slightly reduces both morning and afternoon ramp rates, while east-only solar mitigates the evening ramp rate at the expense of morning. These results may provide some insight for utility planning purposes, in that during situations requiring curtailment or other drastic control measures, targeting specifically oriented arrays may provide sufficient control authority while affecting fewer arrays.

4. Conclusion

Increased deployment of solar energy has the potential to introduce challenges to grid operations and reliability. Anticipating and planning for these challenges is a possibility from a technological standpoint, but spatially resolved analysis tools are necessary to support the planning process. In this study, we demonstrate the ability of such a tool to provide information on net electrical loads in the City of Philadelphia resulting from an extremely high level of rooftop solar PV development. Comparisons were made between strategies for solar deployment, comparing installing solar at actual rooftop orientations with installing exclusively east- and west-facing arrays. The comparison shows that the E&W strategy has the potential to slightly reduce morning and evening ramp rates associated with the duck curve in the PECO region. While this orientation comparison demonstrates the ability of this tool to provide relevant data to decision makers with a stake in solar energy, other comparisons are facilitated by the tool as well. A few examples include identification of ideal levels of deployment with respect to reductions in ramp rate, identification for strategies for targeting of specific problem times in the net load profile, or planning of potential economic incentives to achieve a desired load profile based on solar development. Further development of spatially-resolved decision making tools for renewable energy is needed to provide avenues for these questions to be investigated and answered.

5. References

- Bayrakci Boz, M., Calvert, K., R. S. Brownson, J., 2015. An automated model for rooftop PV systems assessment in ArcGIS using LIDAR. *AIMS Energy* 3, 401–420. doi:10.3934/energy.2015.3.401
- Denholm, P., O’Connell, M., Brinkman, G., Jorgenson, J., 2015. Overgeneration from Solar Energy in California: A Field Guide to the Duck Chart (No. NREL/TP-6A20-65023). National Renewable Energy Laboratory.
- Lew, D., Schroder, M., Miller, N., Lecar, M., 2015. Integrating Higher Levels of Variable Energy Resources in California. GE Energy Consulting.
- National Renewable Energy Lab, 2014. SAM Simulation Core SDK | System Advisor Model (SAM) [WWW Document]. URL <https://sam.nrel.gov/content/sam-simulation-core-sdk> (accessed 12.23.14).
- PJM, 2016. 2014-hourly-loads.xls [WWW Document]. PJM - Metered Load Data. URL <http://www.pjm.com/markets-and-operations/ops-analysis/historical-load-data.aspx> (accessed 6.22.16).
- Wilcox, S., 2012. National Solar Radiation Database 1991-2010 Update: User’s Manual (No. NREL/TP-5500-54824). National Renewable Energy Laboratory.

Resource Assessment: Forecasting & Remote Sensing



Forecasting Solar Power and Irradiance – Lessons from Real-World Experiences

Stephen D. Jascourt¹, Daniel Kirk-Davidoff¹ and Christopher Cassidy¹

¹ MDA Information Systems LLC, Gaithersburg, MD (United States)

Abstract

MDA Information Systems, LLC developed a solar irradiance and power forecasting system based on a first principles science foundation employing high-quality scientific datasets such as AERONET and SURFRAD and utilizing the REST2 clear sky model as an underlying basis for the full-sky forecast. Real-time inputs include a diverse multi-model ensemble of numerical weather prediction (NWP) forecasts, ground-based solar monitoring observations and proprietary observations of solar power from client sites, and visible satellite imagery. Forecasts were made for challenging locations where daytime cumulus clouds and occasional storm systems passing through resulted in variability on time scales of minutes, hours, and days.

This paper focuses on lessons learned from our experience with real-world data and real-world power and irradiance forecasts. Topics include quality control of irradiance and power observations, sub-hourly variability and inverter-limited sites, tracking angles for single-axis trackers, and situational bias of NWP forecasts.

Keywords: *Data, ensemble, forecast, irradiance, model, numerical weather prediction, observations, power, quality control, real-time, tracking, variability*

1. Introduction

As the installed capacity of solar power has been rising exponentially, integration on the grid and the effect of solar power on power prices and markets has stimulated interest in forecasts of solar power and irradiance at solar farms and aggregated across collections of utility-scale and behind-the-meter distribution side installations. In some regions, this interest has reached the point where interested parties are procuring forecasts, while in other regions, the need for forecasts is anticipated to be coming soon, stimulating forecast trials and other assessments of how or when forecasts may provide value.

Anticipating this need for forecasts, MDA Information Systems, LLC began developing a forecast system for power and irradiance several years ago based on first principles and has continued to improve and expand its capabilities. Relationships with clients as well as participation in trials and collaborative projects has allowed us to obtain and analyze proprietary site observations of power and co-located or nearly co-located GHI and/or plane-of-array irradiance at time resolutions of five minutes or finer, at mid-latitude and tropical locations, in arid and humid climates, in continental and coastal locations, in all seasons. Likewise, we have obtained and analyzed ground-based irradiance measurements from publicly available sources, some of which are from high-quality well-maintained networks and others which are not. Quality control of both proprietary and public data is essential to using it in the forecast system as well as for validation of the forecast. After rigorous quality control including consistency checks among related parameters, the data can be used to investigate interesting questions such as deriving the actual operating tracking angles for sun-tracking arrays and examining sub-hourly variability.

This short paper highlights lessons learned from our analysis of real-world data and from our forecasts. We

begin with an overview of the forecast system and then delve into some of the issues we encountered and how we addressed those issues.

2. Overview of MDA solar power and irradiance forecast system

The state-of-the-science MDA solar forecasting system is based on predicting irradiance, parsing the irradiance into direct and diffuse components, projecting it onto plane-of-array irradiance corresponding to a photovoltaic panel installation at a particular orientation which can be a function of time of day or sun angle, and running that through an empirical power curve based on that site or similar sites to obtain a power forecast. Global horizontal irradiance (GHI) is used from a multi-model ensemble of weather forecast models which includes the European Center for Medium Range Weather Forecasts (ECMWF), the NOAA High Resolution Rapid Refresh Model (HRRR), and others. For each individual model forecast, the GHI is nonlinearly bias-corrected through tuning against quality-controlled ground-based GHI measurements and other parameters over a recent history period, then prorated as a fraction of clear-sky conditions to match the diurnal curve down to 1-minute intervals. Because the model output typically represents hour or longer time averages but high-amplitude variability on a time scale of a few minutes can decrease the hour average power output by several percent for the same average irradiance, stochastic variability is added at 1-minute time scales. The stochastic variability is added using asymmetric distributions corresponding to the clear sky fraction and having appropriate temporal coherence. Then, the 1-minute GHI is parsed into direct and diffuse components and projected onto the panels to generate a plane-of-array (POA) irradiance, accounting for the extra circumsolar diffuse irradiance and ground-reflected light appearing on tilted panels. The POA irradiance is converted to power using multivariate empirical relationships derived from quality-controlled site data if available, otherwise using simple assumptions or applying the relationships found for other similar sites. This process is repeated for each individual model run and the results are blended using skill-based weights to produce the optimal forecast and the results are used collectively to generate forecast probability distributions. Additionally, satellite and real-time site data are employed to refine or correct the first few hours of the forecast.

The clear sky basis fundamental to this forecast approach employs the well-validated REST2 clear sky model (Gueymard, 2008), which calculates the clear sky transmissivity for GHI and for the direct beam. The accuracy of REST2 relies on good inputs of various scatterers and absorbers, including aerosol loading and Angstrom exponents and column water vapor, among others. The column water vapor comes from the model forecast. MDA analyzed years of sun photometer data from the NASA Aerosol Robotic Network (AERONET) together with weather model data to derive relationships between the weather parameters and the aerosol parameters. These relationships vary geographically and seasonally, allowing us to generate an aerosol parameter forecast tied to the weather forecast, resulting in better irradiance agreement with observations than by using persistence or static climatology. The parsing of all-sky (when not clear) GHI to direct and diffuse components combines the clear sky analysis with years of data from the Surface Radiation Network (SURFRAD), the gold standard in ground-based irradiance data, to yield relationships allowing us to derive the all-sky direct and diffuse components. Likewise, the 1-minute stochastic distributions of clear sky fraction were derived from a combination of SURFRAD data for all-sky irradiance and REST2 applied using our methodology and model data to yield the corresponding clear-sky irradiance.

More information about the forecast system is available in Jascourt et al. (2013, 2014, 2015, and 2016).

An example illustrating the quality of the forecast is shown in Figure 1. Fifteen-minute averaged forecast power at 1-hour lead time (blue) and metered power output (red) show remarkable agreement every day over a week, including clear and cloudy days with low and high variability despite no site data at all (neither real-time nor delayed) available from the preceding five weeks up to forecast time.

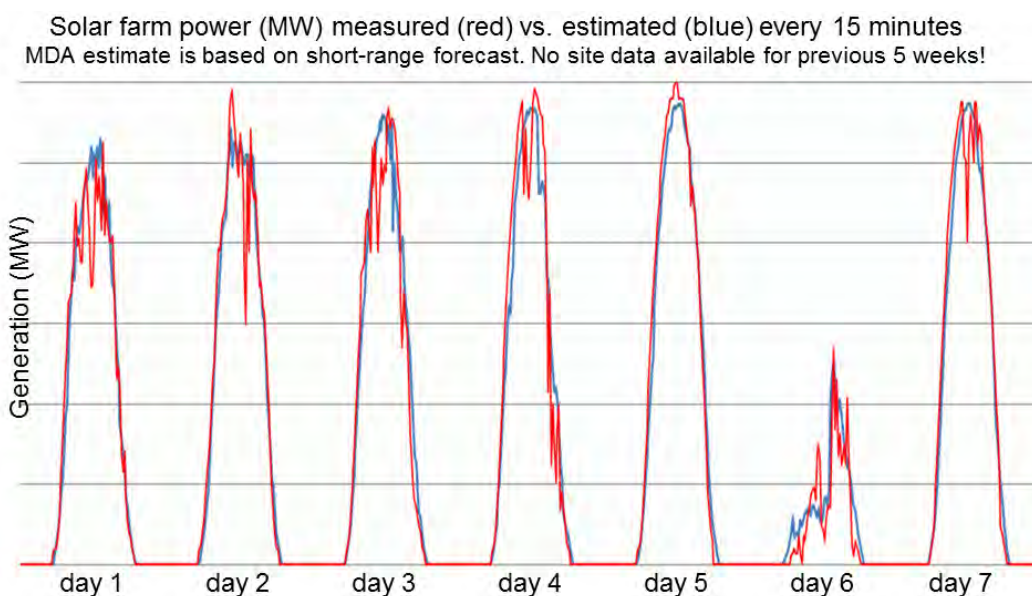

Fig. 1: One week of one-hour-ahead power forecasts for 15-minute blocks vs. actual power. No site observations were available for the preceding month up to forecast time.

3. Lessons learned from real-world experience

3.1. Quality control of PV site observations

PV farms always have power observations. Often the data recorders get stuck, for periods ranging from a few minutes to a few days. The latter are easy to detect but the former not, because values can also be stable for short periods and even at peak output for long periods at inverter-limited sites. Values can be cross-checked against calculated clear sky estimates to flag values which are unrealistically too high for the time of day. Also, in our experience so far, it is rare for a PV farm to produce exactly zero output even on a cloudy day when the sun is more than around 5 degrees above the horizon (accounting for terrain), so those zeroes are often spurious.

PV sites which report POA irradiance offer many more possibilities for quality control. If only GHI is reported, POA can be calculated. Then, the consistency between POA and power can be calculated. We have found many occasions at many sites when there were large discrepancies between POA and power. Sometimes this occurs at isolated times but more often in contiguous blocks of time, and it can help identify whether stuck power values are plausible. However, sometimes the problem is with the irradiance monitor. For example, sometimes shadowing occurs due to power poles or other objects. This can be detected by looking at irradiance as a fraction of clear sky irradiance versus azimuth and zenith angle to see if the fraction is consistently small at the same azimuth for a range of zenith angles. We have even detected brief shadows caused by wires using data at 1-minute intervals and highly accurate sun position calculations.

PV sites which report both GHI and POA irradiance offer even more cross-check possibilities. An example is shown in Figure 2 for a fixed tilt site at low latitude. On this day, the clear sky POA (green) was slightly less than the clear sky GHI (red) but the two were nearly identical. The morning was mostly clear; clouds developed by mid-day, intermittently blocking the sun, and a cloud deck moved in front of the sun towards the end of the day. Measured POA (white) was close to the clear sky curve in the morning while GHI (yellow) was lower by almost 200 W/m². Similar discrepancies occurred over several weeks only during the mid to late morning. Thus, there must have been something partly shadowing the GHI sensor while the POA sensor had good exposure.

3.2. Determining actual angles for sun-tracking PV arrays

The forecast of POA irradiance and power is highly sensitive to the panel orientation during the morning up-

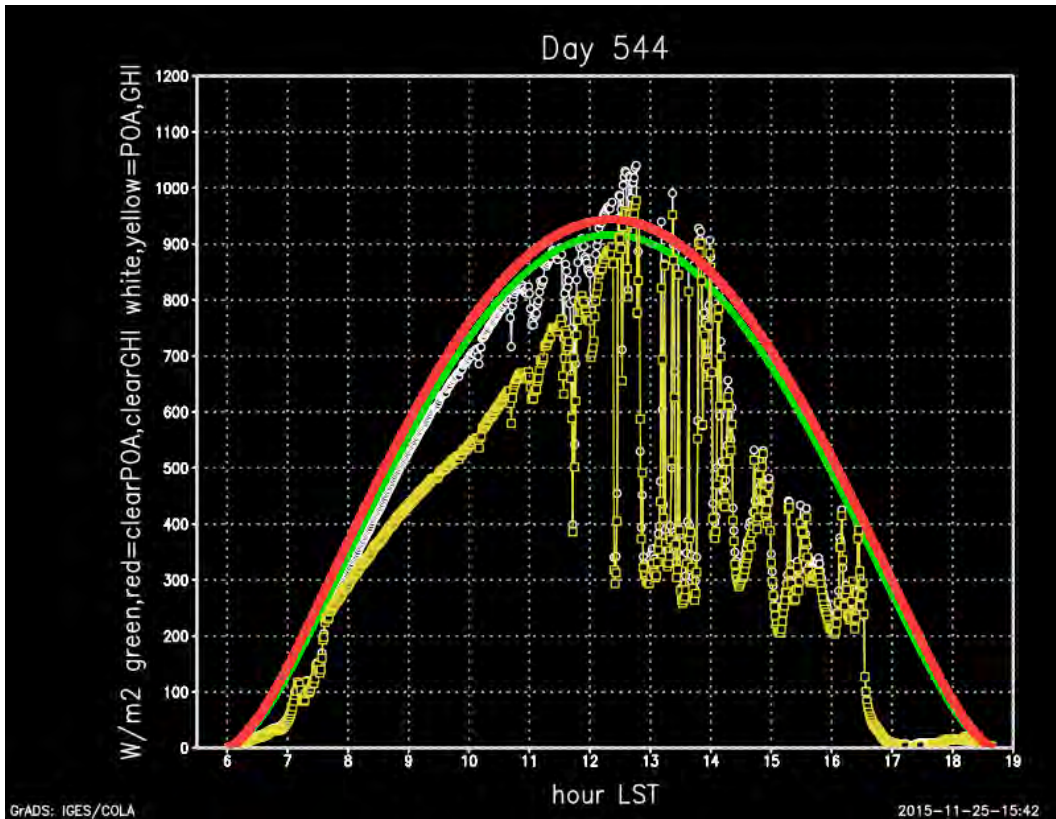
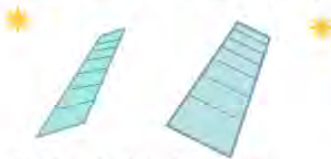

Fig. 2: GHI sensor shadowed from around 8:00 AM to noon, based on measured POA (white) indicating nearly clear sky conditions (green, calculated) while measured GHI (yellow) is far less than for clear sky (red, calculated)

Where is the PV array pointing?

Example:
Single-axis sun-tracking array



MDA calculated array tilt using site data

- Not always optimal
- Not manufacturer specs
- Panels rest horizontal overnight, ~2 hours to reach optimal tilt morning, evening

PV panel tilt angle

→ amount of sun on panel

→ **power output**

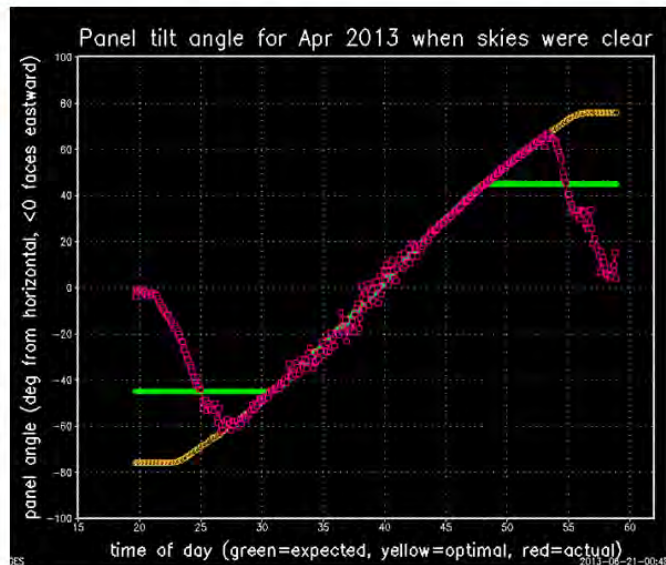

Fig. 3: Single-axis tracking angles for north-south axis tilting toward east (negative values on vertical axis) in morning (left) and toward west (positive) in afternoon (right). Yellow is optimal, green cuts off at manufacturer specifications (maximum tilt 45 degrees) and red is calculation from site data

ramp and evening down-ramp. This would be easy to deal with if we were to assume the tracking followed manufacturer specifications for tilt angles and followed the sun to the maximum extent the equipment can handle. However, in all sun-tracking systems we have encountered in all different geographic areas, the panels rest horizontal at night and can take up to a few hours to reach optimal orientation in the morning, then start heading down again at approximately the same rate to reach horizontal at sunset. MDA calculates the actual tracking positions based on site data. We have found that the rate of transition between the resting position and the optimal position varies from one site to another and the maximum tilt angle from horizontal often exceeds the manufacturer specifications, sometimes by a large amount. An example is shown in Figure 3 for a single-axis tracking array with a north-south axis. The panels take around 2 hours to reach optimal tilt toward the east in the morning, then start heading back to horizontal around 2 hours before sunset, reaching peak tilts of around 60 degrees although the manufacturer specifications indicate a maximum tilt of 45 degrees.

3.3. Quality control of public irradiance monitoring data

There are a variety of publicly available irradiance data sources, some of which report every few minutes and some only hourly.

Quality varies widely. For example, RAWS sites are abundant but are rarely serviced and, as they are intended to provide information in forests for the US Forest Service, they are located in forest clearings which still leave substantial shadows during morning and evening. Because they are abundant, some prominent research and private sector organizations building gridded GHI products tune their output to match the RAWS observations, claiming excellent fit to observations despite actually having poor fit to reality.

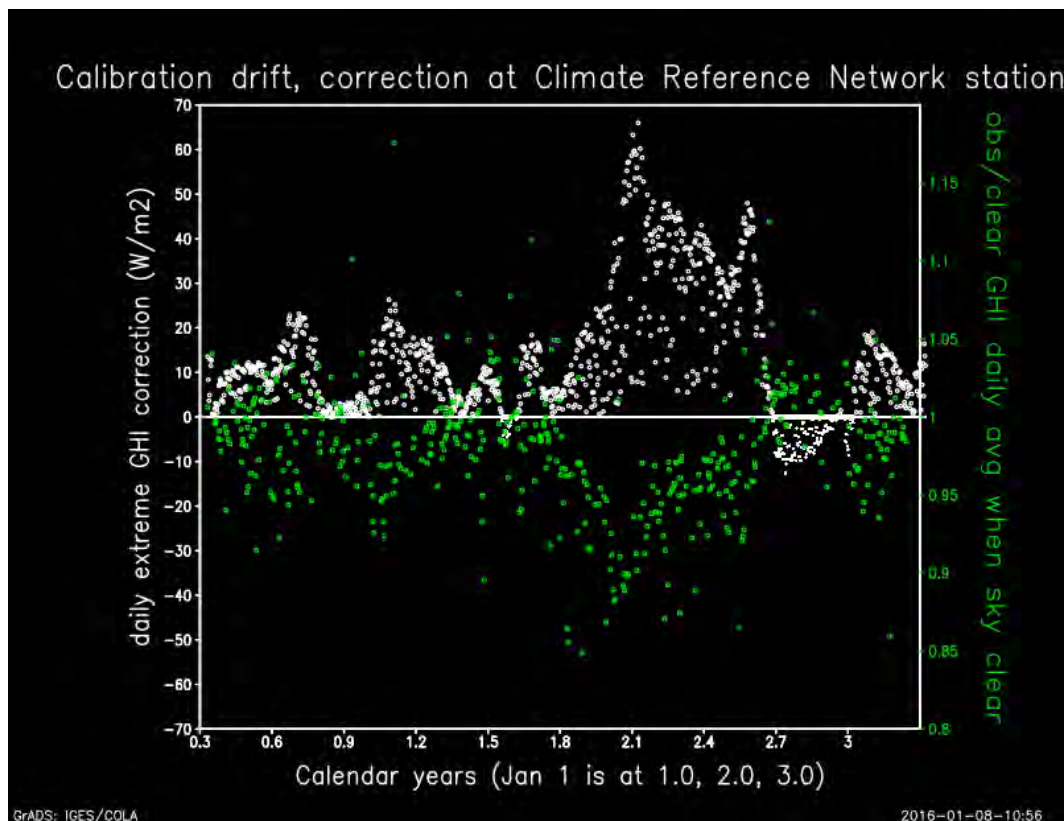

Fig. 4: Calibration drift and correction at a US Climate Reference Network station. Green shows the daily average of the ratio of GHI to clear sky GHI for times of day when skies were clear, over a 3-year period with date progressing from left to right (scale on right) . Estimated GHI corrections were applied and the largest amplitude corrections for any time of day are in white (axis on left)

However, even good quality observations at annually maintained sites can have issues. Figure 4 shows calibration drift or sensor soiling and corrections we applied for a Climate Reference Network site. This shows the value of having a good clear sky model to check against observations during identifiable clear sky times. The site tends to drift toward low values until it is serviced, then it is better for a while. Seeing this, we make corrections to level out the clear sky fraction at 1.0 and prorate the corrections also to times when the sky is not clear. The corrections are usually small but on some days the peak corrections can be rather large. These data after correction are then used for tuning forecast model GHI values.

3.4. Sub-hourly variability

We are finding that while we cannot predict the minute when an individual cloud will pass in front of the sun tomorrow, we can predict which hours will have rather steady cloud conditions and which hours will have rapid fluctuations. Our method involves careful statistical analysis of years of research-quality data. Figure 5 shows an example. The white dots are measured 1-minute GHI averaged over 5 minutes. The green dots come from averaging the observations over an hour and then applying the statistical method to synthesize one-minute values and then taking 5-minute averages. This simulates a perfect one hour forecast where we have no information about details during each hour. The statistical method recovers the wild fluctuations at the correct time even though the values for each minute are not correct during the period of high variability. We did this because the fluctuations affect the hourly average power generation, so it improves our forecast of total power generation for the hour. When the peak values during periods of high-amplitude fluctuations exceed the maximum which the PV-inverter system can output for, the power output is capped. However, the downward spikes are matched in amplitude in the power output. Thus, the average power is lower than the power based on the average irradiance. We calculate that this difference can reach a few percent of capacity at times although it is usually smaller. This stochastic method also provides a side benefit because the forecast amount of sub-hourly variability may also be of interest to the electric industry.

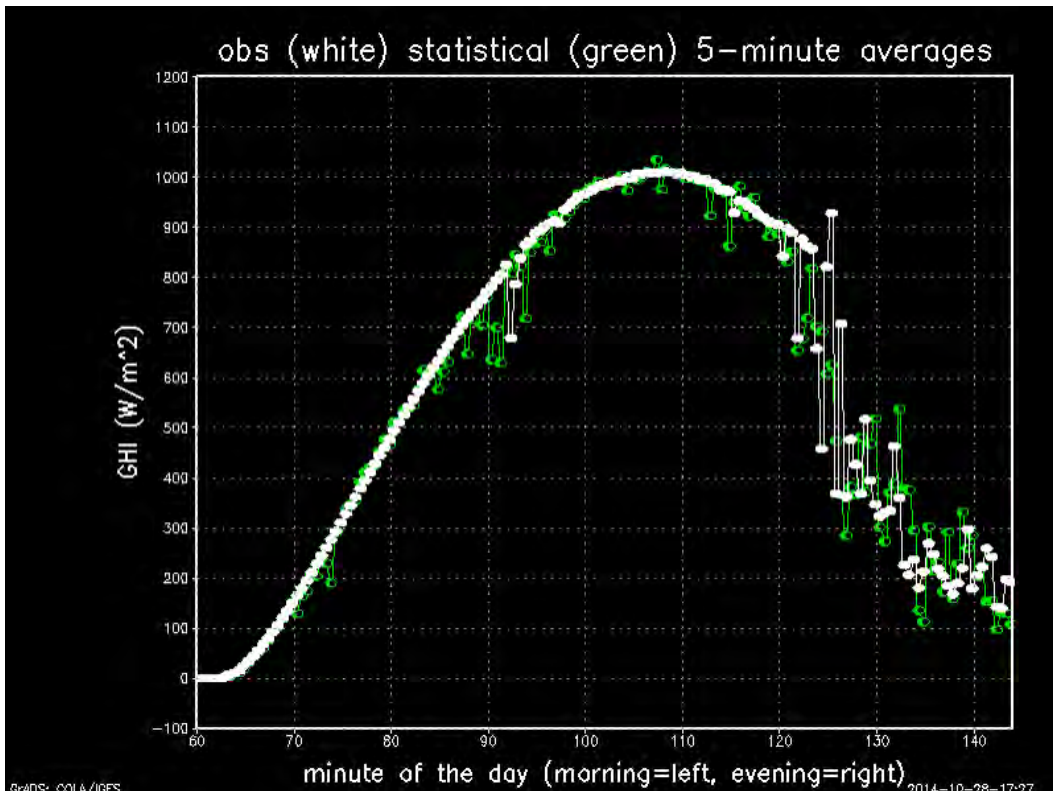

Fig. 5: Stochastic sub-hourly variability (green) versus actual (white). Observed and statistical values are 5-minute averages of 1-minute values. Statistical values receive only information about hour averages and attempt to recover the actual variability. Therefore, hourly averages of the two should match but 5-minute values would only match by chance. The goal is to match the observed variability.

3.5 Forecast bias

The Numerical Weather Prediction (NWP) model forecasts tend to be too sunny, particularly in winter and spring, in all different regions we have examined, and at all lead times including the first hour after the model is available (a few hours after model initialization due to latency for data ingest and computation and dissemination). We found this for ECMWF, GFS, NAM, RAP, and HRRR and will examine others. Power forecasts derived from passing the model forecasts through the MDA solar forecast system verify with little error on clear days, but on cloudy days, many of the model forecasts show nearly clear conditions.

The cause of the too-sunny forecasts are varied. Some cases involved poor forecasts of the movement of cut-off lows, others involved low-level moisture trapped under inversions that did not mix out as much or as soon as predicted, and there were cases of mesoscale cloud features associated with convection, sea breeze and other convergence zones, and other situations.

While model blends reduce error, bias remains. Even skill-weighting the contributions from each model does not improve this situation much. However, giving additional weight to cloudier forecasts does help.

Figure 6 shows 3-month bias in forecast power derived from different models (colors) at different lead times (different lines of the same color) as a percentage of AC capacity (vertical axis) throughout the day (horizontal axis). Figure 7 shows the forecast from various models and lead times for a clear day at one site, illustrating that correctly predicted clear days are not contributing most of the bias. Rather, the bias is due to predicting too many sunny days, with problems even in short range forecasts for later the same day.

The MDA forecast accuracy was improved and bias reduced by applying heavier weighting to models predicting lower irradiance in the MDA forecast blend.

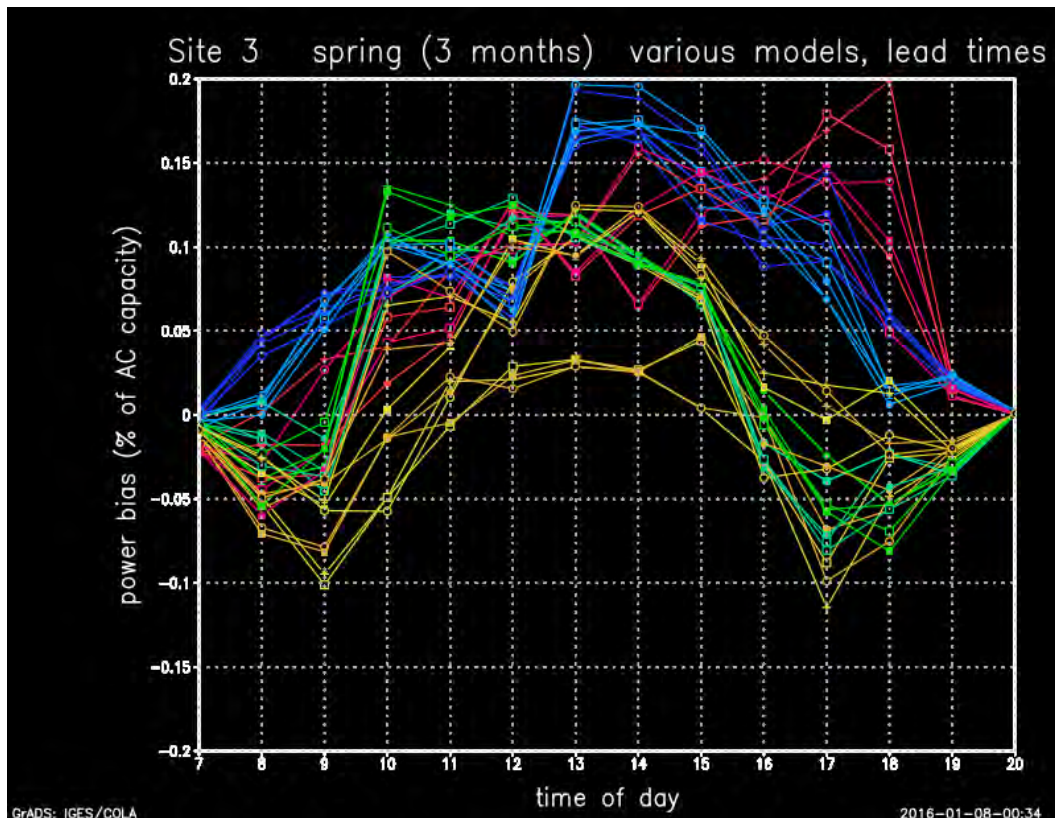

Fig. 6: Bias of power derived from NWP model irradiance forecasts over a three month period as a function of time of day (hour in local standard time). Each color is a different model. Each line is for forecasts of different lead times. Most of the forecasts are showing large mid-day to afternoon bias of 5 to 15 percent.

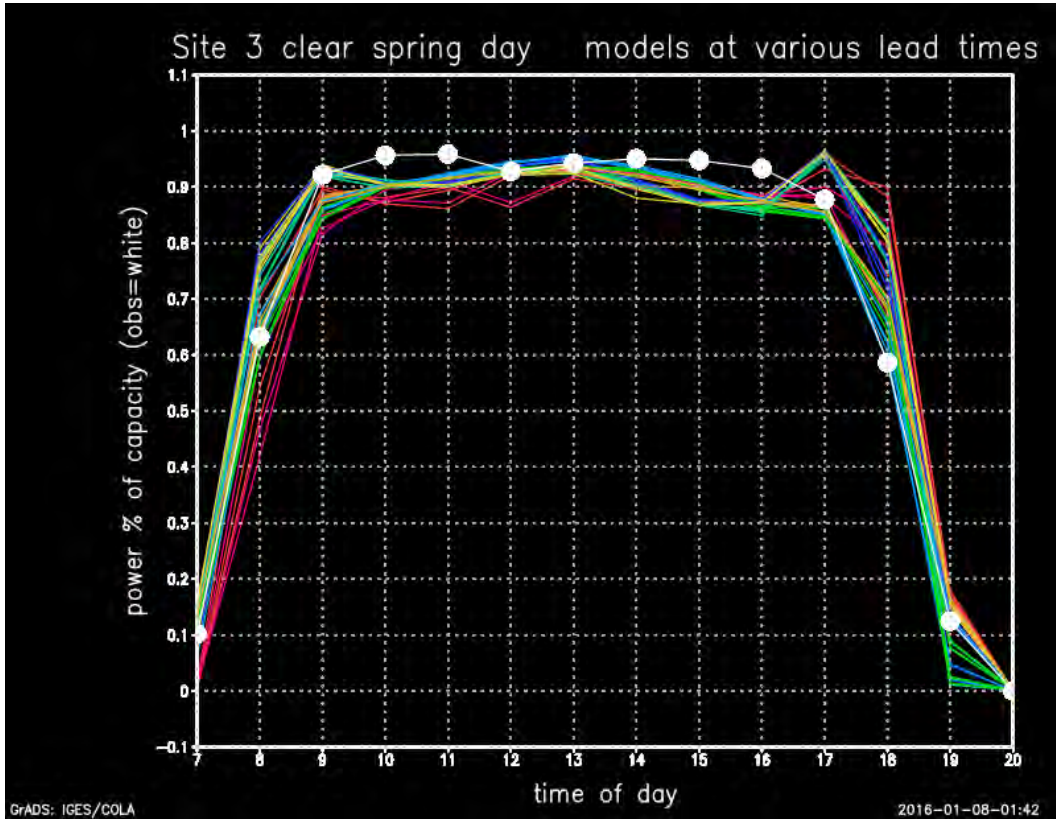

Fig. 7: Forecasts for one day for the same solar farm as in Figure 6 using the same colors for the same underlying NWP models and different lines for the same sets of lead times. This was a clear day, with observed values plotted in white. It does not show the high bias in the three-month average values shown in Figure 6, indicating that those high values are not due to overpredicting power on sunny days.

4. Conclusion

MDA has developed a sophisticated state-of-the-science solar power and irradiance forecasting system. The forecast system even simulates sub-hourly variability. Experience analyzing both proprietary site power and irradiance measurements and public irradiance monitoring data have led to emphasis on data quality control to filter an extensive variety of erroneous and suspect measurement reports and correct those which are correctable and to ascertain actual operating conditions such as orientations of sun-tracking arrays when those have differed from manufacturer specifications. Better results could be obtained if actual tracking were directly and accurately reported and if observing and monitoring systems were better maintained. Additionally, most numerical weather prediction models predict higher irradiance than observed on cloudy days, even at rather short lead times. Improvements in the underlying model forecasts might result from better parameterization of boundary layer mixing and other boundary layer physics as well as improvements in microphysics affecting cloud optical thickness. Meanwhile, MDA mitigates against model bias through the manner in which model forecasts are weighted in the multi-model ensemble.

5. References

Gueymard, C. A., 2008: REST2: High-Performance Solar Radiation Model for Cloudless-Sky Irradiance, Illuminance, and Photosynthetically Active Radiation – Validation with a Benchmark Dataset. *Solar Energy*, 82, 272-285

Jascourt, S.D., D. B. Kirk-Davidoff, C. Cassidy, and T. Hartman, 2016: The forecast is too sunny and the observations are biased. 7th Conference on Weather, Climate, and the New Energy Economy, New Orleans, LA, Amer. Meteor. Soc. [Available online at <https://ams.confex.com/ams/96Annual/webprogram/Paper288708.html>]

Jascourt, S.D., D. Kirk-Davidoff, C. Cassidy, and T. Hartman, 2015: The MDA Solar Power Forecast System: Sub-hourly variability and behind-the-meter generation. 6th Conference on Weather, Climate, and the New Energy Economy, Phoenix, AZ, Amer. Meteor. Soc. [Available online at <https://ams.confex.com/ams/95Annual/webprogram/Paper269331.html>]

Jascourt, S.D., D. Kirk-Davidoff, C. Cassidy, and T. Hartman, 5 February 2014: Forecasting Electric Generation from Solar Energy. 5th Conference on Weather, Climate, and the New Energy Economy, Atlanta, GA, Amer. Meteor. Soc. [Available online at <https://ams.confex.com/ams/94Annual/webprogram/Paper236483.html>]

Jascourt, S.D., D. Kirk-Davidoff, C. Cassidy, and L. Heitkemper, 9 January 2013: Solar Energy Irradiance and Electric Generation Forecasting. 4th Conference on Weather, Climate, and the New Energy Economy, Austin, TX, Amer. Meteor. Soc. [Available online at <https://ams.confex.com/ams/93Annual/webprogram/Paper222941.html>]



An Assessment of New Satellite Data Products for the Development of a Long-term Global Solar Resource at 10-100 km

Paul W. Stackhouse, Jr.¹, Patrick Minnis¹, Richard Perez², Manajit Sengupta³, Kenneth Knapp⁴, J. Colleen Mikovitz⁵, James Schlemmer², Benjamin Scarino⁵, Taiping Zhang⁵, and Stephen J. Cox⁵,

¹ NASA Langley Research Center, Hampton, VA (USA)

² SUNY-Albany, Albany, NY (USA)

³ National Renewable Energy Laboratory, Golden, CO (USA)

⁴ NOAA National Center for Environmental Information, Ashville, NC (USA)

⁵ Science Systems and Applications, Inc., Hampton, VA (USA)

Abstract

A project representing an effort to reprocess the NASA based solar resource data sets is reviewed. The effort represented a collaboration between NASA, NOAA, NREL and the SUNY-Albany and aimed to deliver a 10 km resolution, 3-hourly data set spanning from 1983 through near-present. Part of the project was to transition project capability to NREL for annual processing to extend data set. Due to delays in the key input project called ISCCP, we evaluate only Beta versions of this data set and also introduce the potential use of another NASA Langley based cloud data set for the CERES project. The CERES project uses these cloud properties to compute global top-of-atmosphere and surface fluxes at the 1x1 degree resolution. Here, we also briefly discuss these data sets in potential usage for solar resource benchmarking.

Keywords: *Solar irradiance, solar resource, clouds, NASA, CERES, SSE, GEWEX SRB*

1. Introduction

Considering the possibility of global climate change and the global competition for energy resources, there is a need to provide improved long-term global Earth surface solar resource information. During the last few years there has been a proliferation of solar resource information at high resolutions spanning 1998 – near present (e.g., Sengupta *et al.*, 2014). However, there still is a need to improve the retrieval algorithms and expand the data sets in consistent and stable ways backwards in time far enough to obtain 20 – 30 year data sets. This paper provides an update to a project previously described in Cox *et al.*, (2013). The project represented a collaboration between the National Aeronautics and Space Administration (NASA), National Renewable Energy Laboratory (NREL), the State University of New York/Albany (SUNY) Atmospheric Science Research Center (ASRC) and the NOAA National Center for Environmental Information (NCEI, formally called National Climate Data Center, NCDC) to provide NREL with a global long-term advanced global solar mapping production system for improved depiction of historical solar resources and variability. An additional goal of the project is to provide a mechanism for NREL to continually update solar resource information on a global scale. The production system relies on the efforts of NOAA and NASA to completely reprocess the International Satellite Cloud Climatology Project (ISCCP) data set that provides satellite visible and infrared radiances together with retrieved cloud and surface properties on a 3-hourly basis beginning from July 1983 for all 8-10 km pixels archived by the project. The previous version of the ISCCP data provided this information for all the world's available geosynchronous satellite systems and

NOAA's AVHRR data sets at a 30 km effective resolution. This information plus additional atmospheric information was used in NASA GEWEX Surface Radiation Budget project to produce the first global long-term maps for solar irradiance at a 1x1 degree resolution which became the basis for the NASA's Surface meteorology and Solar Energy web portal (SSE, Chandler et al., 2007, Stackhouse et al., 2007). Unfortunately, the new version of ISCCP has suffered substantial delays now exceeding 5 years and still is not ready for production. Therefore, existing data sets, entitled the ISCCP B1U (Rossow and Schiffer, 1996) and the NOAA NCEI GridSat-B1 (Knapp et al., 2011) were used to test the development of the algorithms and the eventual data production system. GridSat-B1 also contains all the world's geo-synchronous satellite radiances from 70° N to 70° S. Now, a beta version of the ISCCP HX data set has been provided for testing purposes only. Here we evaluate the application of an updated version of the University of Albany SUNY (State University of New York) solar model (Perez et al., 2002) to this new ISCCP HX data to provide a first cut sample of the solar fluxes and their validation. We also introduce a new set of observations available to the solar community from the NASA Langley Research Center CERES (Clouds and Earth's Radiant Energy System) Mission. The CERES Mission is responsible for the CERES instrument that measures broadband solar and thermal infrared radiances that are directly related to the top-of-atmosphere radiative fluxes. The CERES instruments are on board satellites called Terra, Aqua and Suomi-NPP and are planned for future missions. As part of the CERES production system observations from imagers on board Aqua/Terra and all available geosynchronous satellites are processed to produce a comprehensive set of cloud data products. These products are used to estimate solar fluxes. In addition, the CERES project releases high quantities data products of surface solar related parameters at 1° x 1° resolution. This paper presents a brief overview of the various available data products from NOAA and NASA used to estimate solar irradiances at the relatively high resolution of 10 km to the 100 km scale of the 1 degree data products.

2. Preliminary Results with ISCCP High Resolution Precursors and HX Beta

Previous papers detail the progressive results of using the ISCCP B1U and NOAA GridSat-B1 for solar irradiance estimation at 10 x 10 km resolution. These early results were not made operational due to the plans to release the improved ISCCP HX data set that provides full radiance, cloud and surface retrievals. The effective resolution of this data set is 8-10 km depending upon the sensor to which radiances are subsampled and averaged to obtain. The data is available on a 3-hourly temporal basis. However, the ISCCP HX has been delayed now over 5 years due to the comprehensive nature of the revisions and complications in the production system development. Here, we have obtained the latest version of the ISCCP HX which is still officially in beta version and released only for evaluation purposes. For evaluation of the high resolution

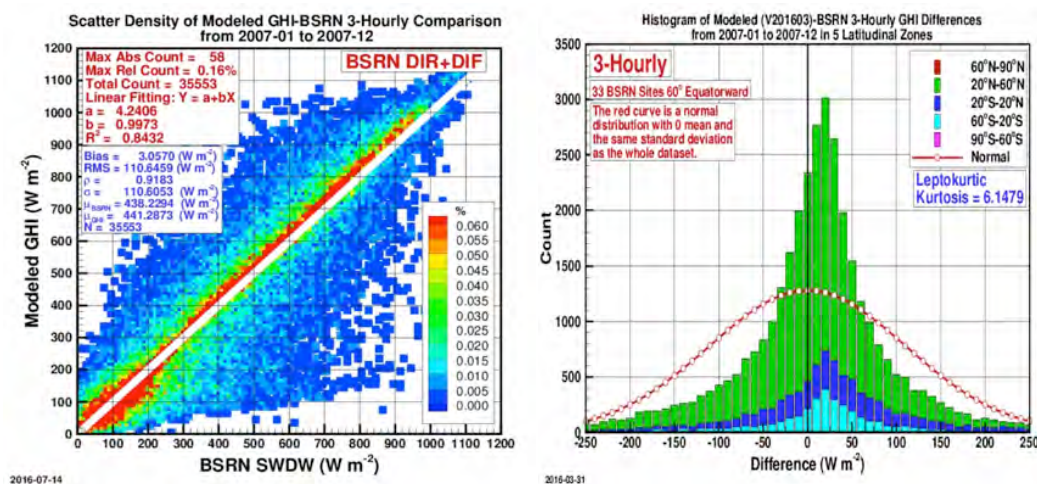

Figure 1: Comparison of 3-hourly solar irradiance estimates using ISCCP HX as input into the SUNY solar algorithm. A density scatter plot (left panel) shows the distribution of the differences with the colors corresponding frequency of differences in the given range as denoted on the legend. The right panel shows a histogram of the differences in a stacked bar chart with each color denoting the given latitude band as denoted in the legend.

irradiances we have computed solar fluxes at the 3-hourly resolution for the world's BSRN (Baseline Surface Radiation Network, Ohmura *et al.*, 1998) sites for the year 2007 using the SUNY algorithm (Perez *et al.*, 2002). Figure 1 shows a density scatter plot of the various fluxes compared to the surface sites (left panel) and a histogram colored by latitude (right panel). We note that despite the relatively small value of the mean difference on the scatter plot, the histogram shows that the distribution of the differences shows a much large bias approaching $15 - 25 \text{ W m}^{-2}$ for nearly all latitude zones. The SUNY and NASA LaRC teams are working understanding the source of these differences. The team has also tested an improved version of the radiative transfer based solar retrieval (improved relative to Stackhouse *et al.*, 2011) using the ISCCP HX and found that at the 3-hourly fluxes gave overall mean difference and RMS of -7.5 W m^{-2} and 85 W m^{-2} respectively at the 1×1 degree resolution and peaks of the distribution centered around $-5 - 5 \text{ W m}^{-2}$. However, it is noted that the RMS differences are consistent with other existing data sets at the high temporal resolution and vary from 25 – 28%.

3. CERES Clouds Data Sets As a Global High Resolution Alternative

As noted above CERES process global cloud products from geosynchronous and polar orbiting imagers (Minnis *et al.*, 2008, 2011). The calibration of these instruments is improved using specialized methods that cross calibrate to the MODIS images. The cloud products begin around 2000 to correspond to the launch of the Terra satellite and extend to near present at a resolution of hourly at $4 \times 4 \text{ km}$. The data sets include a complete set of cloud properties including cloud fraction, optical depth, cloud top and base information and the data is processed up to near-real time. Access to the cloud products and documentation is available at the web site: <http://satcorps.larc.nasa.gov>.

Owing to the delays in the ISCCP HX, we also initiated testing of these satellite cloud products for the estimation of solar fluxes using the improved LaRC model but adapted it to run at full pixel resolution. The solar fluxes were averaged to 25 km and the resulting hourly maps for the monthly averaged hour are shown in Figure 2. These maps show the surface solar fluxes as the sun angles change relative to the cloud fields at each hour. Comparisons of these fluxes to ARM (Atmospheric Radiation Measurement) program gave good results for most cases. However, there were a significant number of cases when there appeared to be a mismatch between the surface and satellite based estimates of solar fluxes. These cases are under investigation. Nevertheless, the success in processing the cloud data properties indicates that future solar resource maps could be derived from these inputs and further testing is planned.

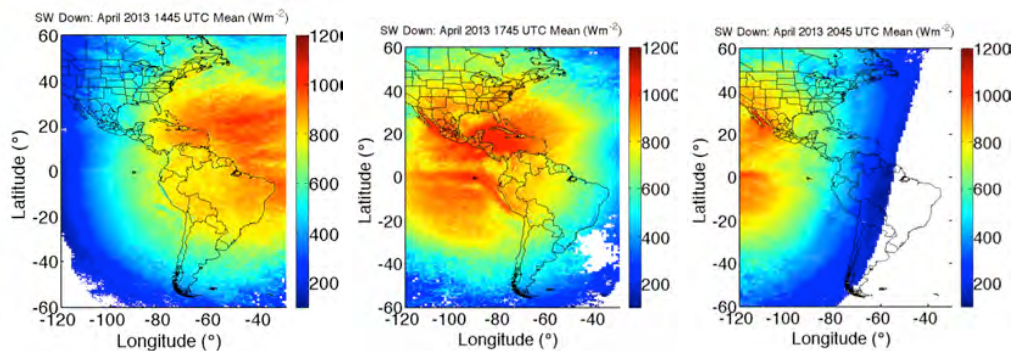

Figure 2: Maps for monthly averaged solar irradiances for 3 different hours (1445, 1745 and 2045 UT), after averaging to 25 km. The solar fluxes are produced using the NASA LaRC CERES Cloud properties.

4. CERES $1^\circ \times 1^\circ$ Data Sets for Long-term for Benchmarking and Long-term Variability

The CERES mission is primarily responsible to produce global radiative flux data products at the top-of-atmosphere and at the surface (Wielicki *et al.*, 1996). CERES produces multiple data sets relevant to the solar energy community. First, there is a CERES footprint level data product called Single Scanner Footprint (SSF). These data vary from 20 km at nadir to 50 km towards the limb. Complete cloud and surface

properties are also included in these data products along with an estimate of the solar irradiance. However, it should be noted that these products are only provided at the overpass times from the Terra (10:30 local time) and Aqua (1:30 local time) satellites. Thus, they are really most useful for coincidence between surface measurements and overpass times. Temporally and spatially gridded data sets are also made available by the CERES mission. All the data products are gridded to the 1° x 1° spatial resolution. However, the temporal resolution varies depending upon the data product use. For time series data within a few months of the present time, the data product entitled SYN1Deg is probably most applicable for the solar industry (Rutan et al., 2015). The data products include the total solar irradiance (or global horizontal irradiance, GHI) and the direct and diffuse components. The current version has data products from 3-hourly to monthly averaged all in UT time. For near-real time radiative fluxes (GHI only), the CERES FLASHFlux (Stackhouse *et al.*, 2006, Kratz *et al.*, 2012) provide daily average global fluxes up to 1 week behind real time. Lastly, the CERES Surface EBAF provides monthly averaged radiative fluxes that are scaled relative to TOA fluxes so that the net TOA fluxes agree with ocean heat content fluxes. These products are mostly used by climate modelers to evaluate the balance of energy at the TOA, are the most accurate in an absolute sense and have the best long-term stability. Table 1 shows the monthly averaged validation for the CERES SYN1Deg and Surface EBAF data products as adapted from Rutan *et al.* (2015). Table 1 shows the validation of CERES Surface EBAF, SYN1Deg, and the GEWEX SRB (Stackhouse et al., 2011) data products (note that GEWEX SRB data products are used for the NASA SSE (Surface meteorology and Solar Energy) data products). The Surface EBAF data products produce radiative anomalies that are extremely well correlated with surface measurement anomalies (Kato *et al.*, 2014).

Table 1: Comparisons of radiative fluxes to BSRN, ARM and ocean buoy measurements on monthly, daily and 3-hourly basis for the years 2000-2007 unless otherwise noted. This table is adapted from Rutan *et al.*, 2015. All units are W m⁻² with % in parentheses.

Data set	Monthly Mean Bias (%)	Monthly mean Std Dev (%)	Daily mean Std Dev (%)	3-hourly Std Dev (%)
CERES Surface EBAF	1.0 (0.0)	12.4 (6.1)	--	--
CERES SYN1Deg	3.0 (1.5)	11.6 (5.7)	31.0 (15.3)	55.5 (27.5)
CERES FLASHFlux ¹	-3.5 (-1.8)	20.5 (10.7)	33.8 (18.1)	--
GEWEX SRB (SSE)	2.0 (1.0)	21.2 (10.5)	37.6 (18.6)	72.2 (35.7)
ERA-Interim ²	7.4 (3.7)	16.8 (8.3)	--	--

¹ FLASHFlux validation from the year 2015 using same set of surface sites.

² ERA-Interim has finer temporal resolution, but it wasn't downloaded here.

All the CERES data products are available via the web page <http://ceres.larc.nasa.gov> and by using the link data access to browse and subset various data products according to user needs. It should also be noted that the NASA LaRC POWER (Prediction of Worldwide renewable Energy Resource) project prepares the daily averaged FLASHFlux data products together with surface meteorological data as a time series accessible at one latitude/longitude location at a time via the web portal: <http://power/larc.nasa.gov> and under the "Sustainable Buildings" link.

5. Summary and Conclusions

This paper described the progress made toward using NASA/NOAA data sets to provide long-term solar resource information using both the NASA GEWEX SW model and SUNY-Albany models. The latter has been tested for use with a beta version of the new ISCCP H series data products. These products are planned for operational production as a climate data record at the NCEI, but continued delays in the data product release have slowed finalization of the algorithm testing and evaluation. However, the preliminary results at the 10 km resolution gave results comparable to currently available methods at least for the total shortwave flux (as know as the global horizontal irradiance or GHI). This paper also showed some very preliminary results using the GEWEX SW model and high resolution cloud properties processed by the CERES Clouds

group at NASA LaRC. These data products are already available to the public via the web site noted above. Lastly, formal CERES data products, produced using those cloud products, were introduced to the solar community. Although, these data products are $1^\circ \times 1^\circ$ horizontal resolution, the validation of the data products shows excellent agreement from daily to monthly temporal scales. The length of these records should prove useful to the solar community for benchmarking purposes.

6. References

- Chandler, W. S., P. W. Stackhouse, Jr., C.H. Whitlock, J.M. Hoell, D. Westberg, T. Zhang, 2007. NASA's Surface Meteorology and Solar Energy Web Portal (Release 6.0). Proceedings of Solar 2007, American Solar Energy Society Meeting, Cleveland, OH, 7 - 12 July.
- Cox, Stephen J., Stackhouse, P.W., Jr., W.S. Chandler, J.M. Hoell, T. Zhang, D.J. Westberg, C.H. Whitlock, R. Perez, C. Hemker, J. Schlemmer, D. Renne, M. Sengupta, J. Bates, and K. Knapp, 2013. Progress towards deriving an improved long-term global solar resource. Proceedings of the Solar 2013 (American Solar Energy Society). Baltimore, MD, 16-20 April.
- Kato, S., N. G. Loeb, F. G. Rose, D. R. Doelling, D. A. Rutan, T. E. Caldwell, L. Yu, and R. A. Weller, 2013. Surface irradiances consistent with CERES-derived top-of-atmosphere shortwave and longwave irradiances. *J. Climate*, 26, 2719–2740, doi:10.1175/JCLI-D-12-00436.1.
- Knapp, K. and Coauthors, 2011. Globally gridded satellite observations for climate studies. *Bull. Of Amer. Meteor. Soc.*, 92, 893-907, DOI: <http://dx.doi.org/10.1175/2011BAMS3039.1>
- Kratz, D. P., P. W. Stackhouse, Jr., S. K. Gupta, A. C. Wilber, P. Sawaengphokhai, and G. R. McGarragh, 2014. The Fast Longwave and Shortwave Flux (FLASHFlux) data product: Single Scanner Footprint Fluxes. *J. Appl. Meteor. and Climatol.*, 53, 1059-1079.
- Minnis, P., L. Nguyen, R. Palikonda, P. W. Heck, D. A. Spangenberg, D. R. Doelling, J. K. Ayers, W. L. Smith, Jr., M. M. Khaiyer, Q. Z. Trepte, L. A. Avey, F.-L. Chang, C. R. Yost, T. L. Chee, and S. Sun-Mack, 2008: Near-real time cloud retrievals from operational and research meteorological satellites. *Proc. SPIE Remote Sens. Clouds Atmos. XIII*, Cardiff, Wales, UK, 15-18 September, **7107-2**, 8 pp., ISBN: 9780819473387.
- Minnis P., S. Sun-Mack, D. F. Young, P. W. Heck, D. P. Garber, Y. Chen, D. A. Spangenberg, R. F. Arduini, Q. Z. Trepte, W. L. Smith, Jr., J. K. Ayers, S. C. Gibson, W. F. Miller, G. Hong, V. Chakrapani, Y. Takano, K.-N. Liou, Y. Xie, and P. Yang, 2011. CERES Edition-2 cloud property retrievals using TRMM VIRS and Terra and Aqua MODIS data--Part I: Algorithms. *IEEE Trans. Geosci. Remote Sens.*, **49**, 4374-4400.
- Ohmura, A., and Coauthors, 1998. Baseline Surface Radiation Network (BSRN/WCRP): New precision radiometry for climate change research. *Bull. Amer. Meteor. Soc.*, 79, 2115–2136, doi:10.1175/1520-0477(1998)079<2115:BSRNBW.2.0.CO;2.
- Perez, R.; Ineichen, P.; Moore, K. Kmiecik, M. Chain, C. George, R. Vignola, F., 2002. A New Operational Satellite-to-Irradiance Model. *Solar Energy*, 73 5, pp. 307–317.
- Sengupta, M., Habte, A., Gotseff, P., Weekley, A., Lopez, A., Anderberg, M., Molling, C., Heidinger, A., 2014. Physics-Based GOES Product for Use in NREL's National Solar Radiation Database: Preprint. 6 pp.; NREL Report No. CP-5D00-62776.
- Stackhouse, P.W., Jr., D. P. Kratz, G.R. McGarragh, S.K. Gupta and Erika B. Geier, 2006. Fast Longwave and Shortwave Radiative Flux (FLASHFlux) Products from CERES and MODIS Measurements. In Proceedings of the 12th conference on atmospheric radiation. Madison, WI, July 10-14.
- Stackhouse, Paul W., Jr., S. K. Gupta, Stephen J. Cox. Taiping Zhang, J. Colleen Mikovitz, and Laura M. Hinkelman, 2011. The NASA/GEWEX Surface Radiation Budget Release 3.0: 24.5-Year Dataset. *GEWEX News*, V 21, No. 1, p10-12, February.
- Wielicki, B. A., B. R. Barkstrom, E. F. Harrison, R. B. Lee III, G. L. Smith, and J. E. Cooper, 1996. Clouds and the Earth's Radiant Energy System (CERES): An Earth Observing System experiment. *Bull. Amer. Meteor. Soc.*, 77, 853–868, doi:10.1175/1520-0477(1996)077<0853:CATERE.2.0.CO;2.

Solar Thermal Technology Advances I



ASES National Solar Conference 2016

'New Standard' Solar Hydronic Building Systems: State of the Art in New Mexico 2016

Bristol Stickney ¹

¹ Solar Heating Engineer, CTO, AllTherm / SolarLogic LLC, Santa Fe, NM (USA)

Abstract

In New Mexico over the past 15 years or so, hundreds of successful Solar Hydronic Combi-Systems have been installed using a systematic design strategy now known as the "New Standard". This well-proven, cookbook approach is the closest thing to 'plug and play' for solar/hydronics in whole buildings to date.

Keywords: *Solar Thermal, Solar Heat, Solar Hot Water, Active Solar, Solar Combisystems, Combisystem, Solar Buildings, Solar Heated Buildings, Solar Hydronics, Solar Hydronic Buildings, New Standard Solar Heating, New Standard Solar Hydronics, Primary Loop, Hydronic.*

1. Introduction

The purpose of this paper is to share our field experience in the solar heating industry with those who may have less experience, or those who are seeking better ways to increase the application of solar thermal uses in their heating-system designs. The reader will learn of applications where hot water produced by solar collectors can be easily allocated to multiple uses with a very simple piping configuration and straightforward control strategies.

2. Focus on Solar Heating

Once a solar heating professional becomes proficient with solar water heaters, the next logical step is to delve into Solar Combisystems. In these systems, the collector arrays become larger, and the heat is distributed to multiple end-uses, not just a single water tank. In a combisystem, it is typical for a large group of collectors to provide heat for space heating, water heating, and other uses such as boiler preheat, pools, spas, ice melt, and heat storage. The piping involved in these systems can seem complex, and the control systems formidable. But the technology has matured and the energy savings can be significant, so solar heating should not be overlooked in high efficiency building construction projects.

The information presented here is essentially a report from the field, drawing upon the experience from well over a hundred solar heated combisystems installed and operating over the past 5-10 years. We have focused on pressurized, closed loop glycol/hydronic solar collector systems, since these systems can be applied in a wide variety of building geometries and orientations with few limitations. Our results and observations have helped to formulate our own recommended best practices, presented here, which can be applied directly to solar heating installations in residential and small commercial buildings (see examples in Photo 1A & 1B). The discussion presented here targets both new and retrofit heating systems in small buildings (typically less than 10,000 square feet) using hydronic heating systems. We have found that a standardized and modular approach to the design, installation and control of solar combisystems can greatly improve the speed and reliability with which they are deployed.



Photo 1: Examples of Small Commercial and Residential Solar Hydronic Combisystems.

3. Why Active Solar Hydronics?

Closed-loop hydronic solar heating collector systems are seamlessly compatible with hydronic boilers, hot water radiators, domestic hot water and radiant-heated floors. Both the solar equipment and the conventional systems operate along the same principles, using similar fluids and fluid pressure, and have compatible temperature ranges. Conventional building construction practices for hydronic heat distribution systems do not need to be altered or re-learned in most cases when solar heat is to be included.

Pressurized solar collectors (closed-loop) can be mounted in a variety of ways, including ground mounting, roof mounts and wall mounts, allowing for flexibility in their application, and therefore compatibility with existing and new buildings without any further technical development. Closed-loop active solar heating systems are assembled, operated and maintained in much the same way hydronic boiler systems are, making them compatible with the skills of our existing hydronic installers. In a number of installations, Drain-back solar heat collectors have also been successfully installed in this type of hydronic configuration when the building configuration allowed for it.

4. The Solar Heating Opportunity

Hundreds of thousands of "hot water boilers" are installed in the US every year. Even if only a small fraction of them could easily benefit from supplemental Solar Hydronic heat collectors, that still represents thousands of solar thermal installations each year. Also, the backlog of hydronic heating systems installed over the past 20 years represents an enormous opportunity for practical solar thermal retrofits. Clearly, there are millions of homes and other buildings that use hydronic ('hot water') heating systems that could benefit from the fuel

savings that solar heating can easily provide.

5. Typical Solar Heating Design Thought Process

Any time someone starts thinking about adding solar heat collectors to a small building project, the thought process invariably proceeds along the same lines. First they think about a solar water heater using only a few collectors. Then they wonder if some of that heat could be connected to their floors or to other space heating jobs. If so, then maybe a few more collectors would be worthwhile. Then they wonder how hard it would be to hook up some other heating jobs to get additional benefit from larger collectors. The design process can be surprisingly predictable and typically includes the following issues:

- Solar Heat Collectors
- Solar Domestic Hot Water Tanks
- Solar Heated (Radiant) Floors
- Hot Water Baseboards or Radiators
- Hydronic Boiler (conventional fuel or other on-demand heat sources).
- Intermittent heat sources like wood burner or ‘waste heat’ from electric generator.
- Can we connect them all together?
- Can we send extra heat to ...the pool, spa, ice melt, hot air fan coils, etc.?
- Do we need big water tanks for heat storage?
- How do we control potential solar overheating?

Every new choice represents a change in the design, different piping connections, additional components, various temperature requirements and different controls.

6. The “Solar Combisystem” Dilemma

Multiple Heat Sources and Multiple Heating Loads can be connected in a bewildering variety of different ways. In our region (Northern New Mexico), the most typical solar-hydronic combisystem includes:

- a solar heat collector array,
- a gas or propane hydronic boiler,
- a domestic water heater with in-tank heat exchanger, and
- a radiant heated floor typically divided into several heating zones.

I call this application “Solar Combisystem 101” (Combi 101), since these basic features have been duplicated so many times for small buildings in recent years.(1) This includes only four items, two heat sources and two heat loads. Yet if you present these requirements to three different heating equipment suppliers, you will very likely get three very different piping and wiring plans with tees, motorized valves and pumps in all different locations and some often cryptic control strategies (or none at all) to complete the confusion. This is what happened in the unfortunate installation seen in Photo 2A. Several equipment suppliers and three different installers made a valiant attempt to install a Combi 101 system in a small residence in Santa Fe. Each had his own idea about the plumbing connections and controls, and each installer eventually gave up in confusion. The result was an unfinished heating system and the proverbial plumbing nightmare seen in the photo.

The proper design and control can be a daunting challenge to any mechanical installer. The makers and suppliers of the components, to their credit, have put a lot of thought into all the different ways their equipment might be installed, and generally provide plenty of choices, suggestions and alternatives so as not to limit the installer. But, all these choices can (and do) serve as a barrier to rapid and reliable deployment of solar thermal combisystems. Each alternative plumbing configuration represents a slightly different operating sequence (and

a different control strategy to go with it) that the installer must understand explicitly if it is to startup and operate successfully over the long term.

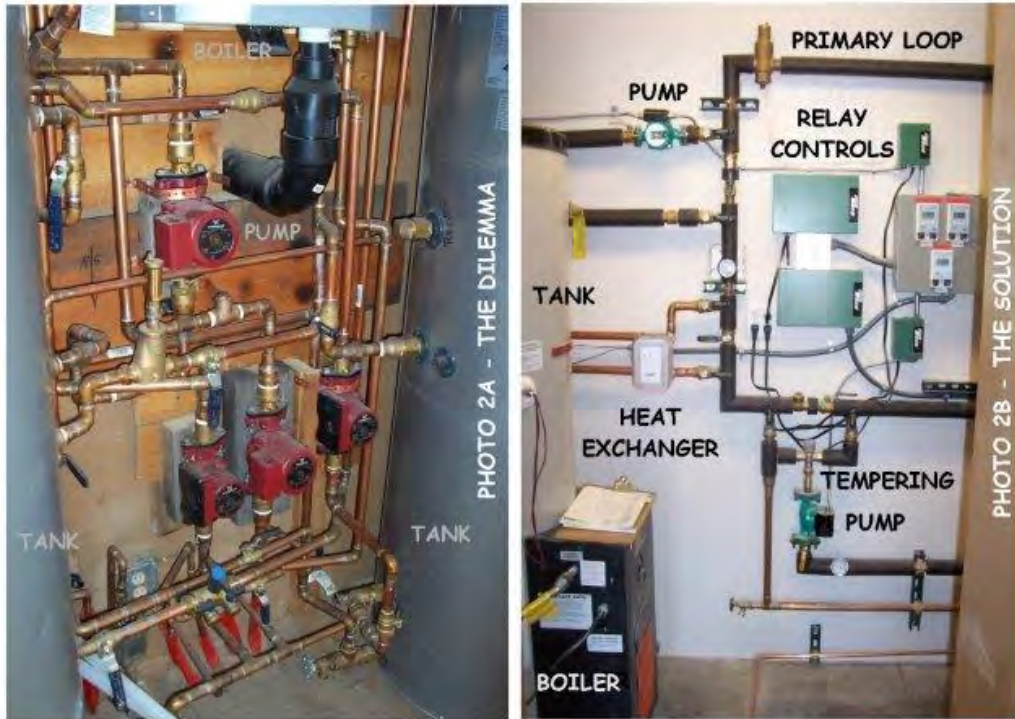

Photo 2: Before and After "New Standard" Primary Loop Design.

7. The Solution by Design

Let's pause for a moment to reflect on what we are ideally trying to accomplish with a combisystem piping configuration.

We have Multiple Heat Sources feeding Multiple Heat Loads. Some of the heat sources are only available intermittently, but those are typically the most desirable with the lowest fuel cost. Not all the heating loads require the same temperature, and some have intrinsic heat storage capacity. Heat-storage water tanks can act both as heat sources and heat loads, so the piping configuration needs to allow for this.

We want to deliver solar heat to any job that needs heat, giving it top priority whenever it is available because of the lower fuel cost. If solar heat is used directly (instead of stored) as soon as it arrives, the delivered solar thermal efficiency is maximized when the energy loss associated with heat storage, extra pumping and multiple heat exchangers is eliminated. The same capability is needed for any other intermittent source of heat when they are connected.

So, a piping configuration is needed that allows any heat source to connect to any heat load whenever the temperature is useful, and allow heat to bypass any heating load when the temperature is not a proper match or it is not needed.

Also, we need a piping configuration that can be modified easily, so that heat sources and heat loads can be added or deleted easily in a standard way so installers can 'plug and play' solar heat, storage tanks, or other equipment without a major re-design.

It may seem like a tall order to meet all these requirements in a single standard piping configuration, but one solution stands out, having been in popular use for decades. The Primary Loop configuration has been more

popular in Commercial buildings than in Residential in the past, but it can be applied to solar combisystems as well. After many solar combi installations in both small commercial and residential buildings, in our experience, the primary loop approach seems to fill the bill nicely. A system can be seen just like this in Photo 2B, which is located inside the residence in Photo 1B. It is a Combi 101 primary loop configuration that performs exactly the same functions as the system in Photo 2A was supposed to do.

8. Primary Loop “Flow Center” Concept

In order to connect all heating sources to all heating loads, a “Flow Center” is needed to allow the supply and return fluid from all the circulator pumps to join together without interfering with one another. This can be accomplished with Primary/Secondary piping using ‘closely spaced tees’ to attach the secondary loops, which plug into the Primary Loop using a two-pipe connection. The Primary Loop acts as a “Hydraulic Separator” allowing all the circulator pumps in the system to operate simultaneously if needed.

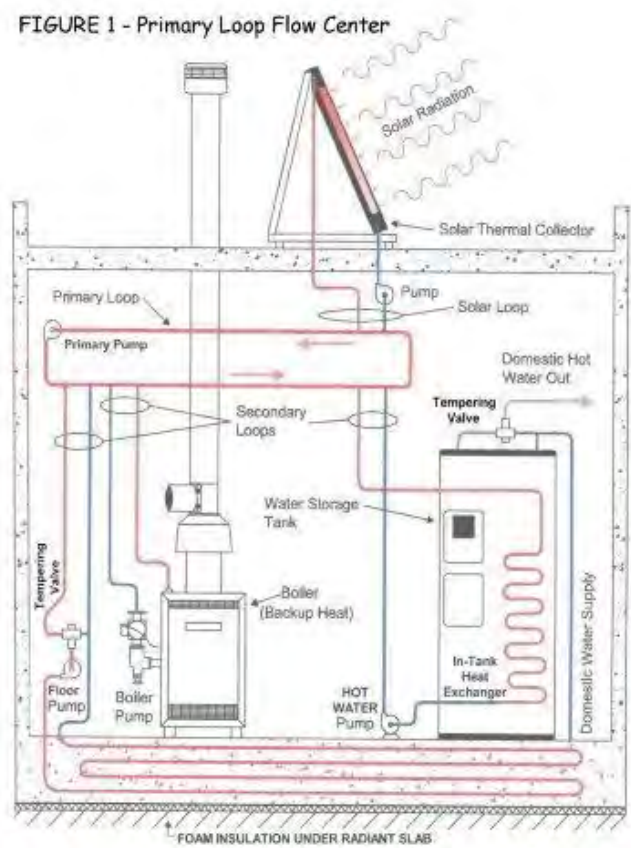

Fig. 1: Primary Loop Flow Center Piping Concept.

Figure 1 illustrates this concept as it applies to a small solar heating system. This diagram is typical of many smaller solar heated homes in Northern New Mexico, where the glycol ‘boiler fluid’ circulates in a pressurized, closed system, directly from the solar collectors into the floors, the boiler, and other heating equipment. This eliminates the need for a Primary Heat Exchanger (separating the outdoor fluid from the indoor fluid), which lowers the cost of these small installations, and improves the solar thermal system efficiency. Solar-direct glycol systems are typically used on smaller projects of less than 2000 square feet.

Notice that the piping transition from copper to the PEX in the floor always includes a thermal tempering valve to protect the plastic tubing from possible solar overheating. Notice also, that if the solar collectors are sized,

mounted and controlled properly with respect for the heat storage capacity of the radiant mass floor and the water heater tank, no other heat-storage water tanks are needed. There are many systems like this installed in our region that combine only the DHW tank and the mass of the floors for heat storage.

9. Temperature Sequencing

Heat sources should be sequenced around the primary loop in order of increasing temperature production, and heat loads are placed in order of declining temperature requirements. This is important in any simple primary loop because the cool return fluid mixes with the hot supply fluid at every secondary connection that has flow. So, for example, the DHW gets higher temperature heat before continuing around the loop to the radiant mass floor. The tees for a higher temperature baseboard system would be placed before the radiant floor tees, and swimming pool heat should be taken after the radiant floor connection. In this way, lower temperature heat sources may always pre-heat higher temperature heat sources, and the left-over 'waste heat' from one heating job can always be used to provide heat to a lower temperature heating job using a relatively simple control strategy.

10. Standardized Primary Loop Configuration Provides 'Plug and Play' Design

The piping configuration seen in Figure 2 provides everything on our wish list mentioned above. Any Heat Source may be connected to any Heat Load or bypassed easily by the control system by simply turning secondary circulators (and zone valves) on or off. Any heating component can provide direct heat, preheat or no heat to any other device mounted on the primary loop.

Each component can be added or deleted, during initial installation or at any time in the future using a two-pipe connection to the primary loop. Modular 'pump stations' can be used with this 'two-pipe' standard to speed up assembly on the job. Using this modular configuration for pipe connections also allows for modular controls. Both the components and the controls can then 'plug and play' together.

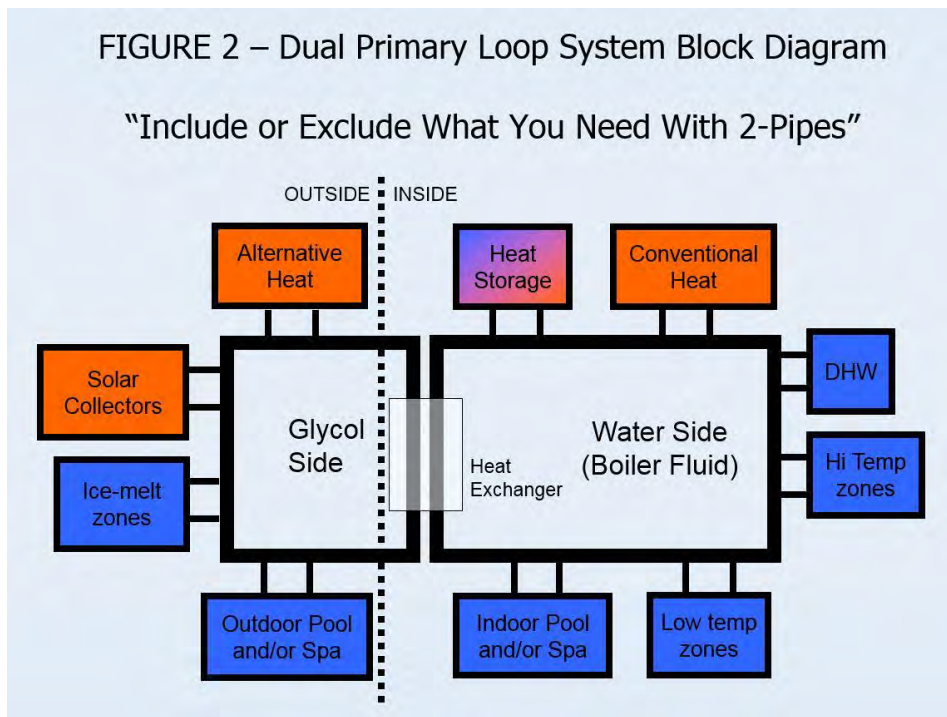

Fig. 2: Dual Primary Loop Block Diagram.

11. Solar Heat Storage in Masonry Floors

Direct active solar heating of masonry warm floors has been done in our region dating back at least to the 1950's.(2) This technique has enjoyed renewed popularity in recent years, thanks to the widespread use of PEX tubing in concrete radiant floors. The idea is to pump heat directly from a solar heat collector into the heat storage capacity of a masonry floor. The floor warms up slowly and stays warm well into the evening on cold sunny days. The challenge is to size the collectors and tilt them so that the floor is provided with a quantity of heat that does not cause overheating at any time of the year. This has a lot to do with the specific heat storage capacity of the masonry material in the floor, which has about 1/2 to 1/3 of the heat storage capacity of the same volume of water.

Fortunately, there is an enormous volume in the radiant mass floors in a typical home construction, capable of storing about 5 times as much heat as a properly sized heat-storage water tank system. Another way of saying this is that the masonry warm floors will operate with temperature fluctuations about 5 times lower than a typical water tank heat-storage system (when solar heated directly using common design strategies). This puts the floor temperature within the range of human comfort, and the lower temperatures result in lower rates of heat loss and higher thermal efficiency. This temperature performance has been observed and confirmed in many field installations.

By some estimates, a bonus of as much as 25% can be realized in fuel savings by bypassing the storage tanks and heat exchangers whenever possible. (3) Also, when the thermal mass of masonry radiant floors is properly integrated and controlled in a New Standard solar hydronic combisystem, the size of the heat storage water tanks can be drastically reduced. In many cases, heat storage water tanks have been completely eliminated when the size of the heat collectors, the size of the mass floors and the climate are properly balanced under intelligent control.

If you take this into account and control the heat in the floor within the comfort range, you realize that you can often eliminate the need for large additional heat-storage water tanks that have been the backbone of big solar heating systems past and present. The floor acts as the "solar accumulator" instead of the more traditional, costly and complex water tank systems. The floor had to be there anyway, so does not contribute much to the added cost of solar equipment.

In our climate, a well-insulated mass floor can be heated with about 10 -15 % of the floor area in collectors, and the collectors work quite well for winter heating when mounted vertically on a south facing wall as seen in Photo 1B. The low winter sun angle provides maximum solar heat to a vertical collector during the cold season. In Photo 1B, the roof overhang was designed to partially shade the collectors in summer when all the solar heat is not needed. Generally, solar heat collectors can be tilted more toward vertical if heat is not needed in summer, because the high summer sun angle inhibits the collectors from gaining heat. They can be tilted back more if there is a big water heater load or a heated swimming pool.

12. Two-Stage Room Thermostats

In a typical solar combisystem, we use 2-stage room thermostats to allow the solar heat to provide a slightly higher set point than the boiler heat in rooms having heat storage in the floors.(4) And we use the primary loop and the existing zone valves to send the solar heat to where ever it is needed most (e.g. the cooler rooms first). Solar heat is delivered to the thermal mass of the floor until the room temperature reaches the limit of the upper differential temperature range. By raising the temperature of a masonry floor just one degree (F), we have stored thousands of BTU's in the thermal mass, which will radiate into the room over a period of many hours, delaying the boiler from turning on.

In this way we are putting the "thermal flywheel" effect of the mass floor to good use, by prolonging the delivery of solar heat well into the evening. The backup boiler will not fire until the room thermostat drops all the way through its entire differential range and the second stage low-limit is triggered. This approach works especially well in buildings that are super-insulated and intentionally designed for 'net-zero' or 'near zero' energy performance.

13. Solar Combisystem Control, From Relays to Software

In the final analysis, the high efficiencies, fuel savings, comfort temperatures, and all the other potential benefits of a solar combisystem cannot be accomplished without reliable and effective controls. Even if all the right equipment is installed and all the piping is correct, there will be no solar savings unless the control system shuts off the boiler and turns on the right pumps and valves in the correct sequence. The building must act much like a hybrid car, sensing when to choose one fuel over another, with consistent, reliable and logical precision.

The most common way this has been done, is to use thermostats, set-point and differential controls that sense temperature changes which activate a relay in response. Each relay can turn a pump or other device on or off. Controls like this can be seen in Photo 2B with temperature controls and green relay boxes strung together in a specific arrangement of wiring.(5) The thermostats are usually digital and have useful programmable functions for tuning the heating performance. But much of the 'programming' of the whole system and the switching logic is in the wiring itself.

In our most recent (50 or so) solar combisystem installations, the old temperature-actuated relays have been replaced with sensors, computer software and hardware. This has proven to deliver a much higher level of control, communication and intelligent logic that was not possible with hard-wired relays.(6)

A detailed discussion of the proper control of these systems and the benefits of using software instead of hardware is not possible here, but can be found in some of the other articles available from this author and associates. When the 'New Standard' piping configuration is employed as described above, the modular plumbing allows a modular control system to go with it. The plumbing and controls are two sides of the same coin. The controls are not an afterthought and can be monitored, controlled remotely and performance verified over the internet.

14. Conclusions

A modular and integrated configuration of piping and controls has become increasingly popular in New Mexico for whole-building solar-hydronic combisystem installations. This design approach, known as the 'New Standard', is based on familiar primary-loop piping principles, and has been duplicated successfully in hundreds of installations in many diverse locations dating back over the past 15 years. When the 'New Standard' piping configuration is employed, the modular plumbing allows for a modular control system to go with it. By using a standard system configuration, the design and installation of these systems can be accomplished very rapidly, there is very little (or no) custom engineering design and long term reliable performance can be assured. The most recent installations are internet-enabled and can be monitored, controlled remotely and their thermal energy performance can be metered and verified over the internet.

15. References

- (1) "The Primary Check-Loop Flow Center", by Bristol Stickney, Plumbing Engineer Magazine, Mar 2009.
- (2) "The Evolution of 'Direct' Active Solar Heating", by Bristol Stickney, Plumbing Engineer Magazine, Nov.2008.
- (3) "Storage Mediums and Temperature Control Strategies", by Boaz Soifer and Bristol Stickney, SolarPro Magazine, Apr/May 2010.
- (4) "Solar Heat Control with Two-Stage Thermostats", by Bristol Stickney, Plumbing Engineer Magazine, Feb. 2009.
- (5) "Basic Combi-System Controls", by Bristol Stickney, Plumbing Engineer Magazine, Sept 2009.
- (6) "Home Solar Heating Retrofit", by Bristol Stickney, Home Power Magazine, Issue #144, Aug & Sept 2011.

Solar Thermal Collection with Seasonal Storage

Gaylord Olson¹, Yao Yu²

¹ Temple University, Mech. Engr. Advisory Committee, Philadelphia, PA (USA)

² North Dakota State University, Fargo, ND (USA)

Abstract

A system will be described which combines several different types of solar thermal collectors with a specific arrangement of valves to optimize the collection of heat and (if needed) the collection of cold. The collection of both heat and cold (dissipation of heat) is possible by using unglazed collectors as part of the system. The system may also include a type of seasonal underground thermal energy storage which is an extension of concepts already in use at Drake Landing Solar Community in Alberta, Canada and ICAX Limited in London, England. The results of simulating the underground heat transfer and thermal storage will be displayed. Factors that could impact the performance of underground heat storage will be discussed, including climate, building location, underground/soil thermal condition, building heating/cooling demands, heat dissipation/loss from the ground, etc. There will be a need to optimize many of the system parameters, such as dimensions, material properties, flow rates, etc. to get the best result for any specific building or set of buildings. It is our expectation that systems such as those described here could be significantly more cost-effective than systems in use currently.

Keywords: *solar, thermal, collector, underground, storage, seasonal*

1. Introduction

In the United States today the terms “solar energy” or “solar power” are nearly always assumed to be related to electricity generation. Other countries seem to have a broader view of the word solar, and have recently shown many interesting new ways to extend solar thermal technology (Good and Gora, 2016; Hesarakı et al., 2015). Pean et al. (2015) have shown the nighttime radiative cooling potential of the unglazed solar collectors and photovoltaic/thermal panels that are typically used for heat collection. Radiation cooling from an unglazed collector can be used on either a diurnal or a seasonal basis. Man et al. in 2011 designed a system that couples unglazed solar collectors located on the roof with underground heat exchangers. This system could be used during night to reject the accumulated heat from the ground heat exchangers to the outside mainly by radiation and convection through the collectors. An experimental and analytical study has been done by Xu et al. in 2015 to evaluate the performance of a radiative cooling system that consists of flat plate collectors. Seasonal thermal energy storage represents the storage of heat or cold with a long-time duration, such as several months (STES, 2016). An example for this is to seasonally store the summer heat in order to use it during cold seasons when heating is needed. An actual thermal energy storage project (Drake Landing Solar Community, 2016) in Alberta, Canada involves the seasonal storage of solar thermal heat collected through 800 solar thermal collectors during summer, which is transferred into the ground through 144 vertical boreholes with a depth of 37 meters for use during winter. It is reported that the ground temperature can be up to 80 °C by the end of summer season, which is sufficiently high for the direct use of the underground heat during winter.

This paper is intended to show some additional new ways to use conventional (and some unconventional) solar thermal collectors to provide both heat and cold collection and to combine these with water source heat pumps for a more cost-effective method of space heating and cooling of buildings. It is also possible that the combination of some of these new methods along with seasonal underground storage and advances in low energy building technology such as passive house designs might allow for cost-effective Heating, Ventilating, and Air Conditioning (HVAC) systems without using heat pumps in the system. Another possibility is the extension of

a flat plate solar thermal collector to include a modification which allows it to be used for efficient heat and cold collection using both radiative and convective thermal transfer for cooling. Many of the concepts described here are included in one or more recent patents or are patent pending.

2. Combining Multiple Collector Types

A large number of different products can be used for collection of solar thermal energy and air to liquid heat exchange (Table 1).

Tab. 1: Multiple collector and heat exchanger types

Solar thermal collection	Air to liquid heat exchange
<ul style="list-style-type: none"> • Unglazed solar panels • Glazed flat plate solar panels • Evacuated tube or parabolic concentrator collectors 	<ul style="list-style-type: none"> • Unglazed solar panels • Fin-and-tube heat exchanger (using water or refrigerant) • Cooling tower

Another way to achieve thermal collection and heat exchange (although it is not a specific product) is to use a horizontal array of pipes that is buried just below the earth's surface. For example, this could be below a parking lot or road (Carder et al., 2007). This concept has been pioneered by a company in London, England: ICAX Limited (www.icax.co.uk).

The products listed in Table 1 have been primarily used in systems where only one product at a time is in use. It is possible that several of the products above can be used together in a single system to give multiple functionality (both heat and cold collection) and also provide improvements in performance and cost-effectiveness.

As an example, consider the need to collect thermal energy with seasonal (very long term) storage. The project described before, Drake Landing Solar Community, uses glazed flat plate collectors exclusively. In this case there is a need for temperatures that are higher than can be obtained from the less expensive unglazed collectors. As a point of reference, glazed collectors are 5 to 8 times more expensive than unglazed collectors per unit area. This means that if low temperatures can be tolerated, the unglazed panels might collect more thermal energy per dollar per year than any other product.

A way to utilize the features of both glazed and unglazed collectors together is shown in Figures 1(a) and 1(b). These figures show a series connection between the two arrays of panels (collectors), however a three-port valve is used to bypass around the unglazed panels when this is called for. It is assumed that there are temperature sensors and a computer to automatically control the valve condition. The method of operation is such that on a calm, warm, sunny day the valve is set such that the water flows through the unglazed array to be preheated before being more completely heated with the glazed array. The term "array" here is intended to mean one or more panels connected in a series, parallel, or series-parallel arrangement. Figures 1(a) and 1(b) show nearly identical functionality. The optimum choice might relate to where the best physical locations of valves and pipes are in a given installation.

To be more specific about the operation of Figures 1(a) and 1(b), it is known that the efficiency of these collectors can be represented in Equation 1 and depends primarily on three parameters:

- incident irradiance on the collector
- inlet water temperature
- ambient air temperature

$$\eta = F_R \tau \alpha - F_R U_L \left(\frac{T_{in} - T_a}{I} \right) = \frac{m \cdot c_p (T_{out} - T_{in})}{A \cdot I} \quad (\text{eq. 1})$$

where m (kg s^{-1}) is the mass flow rate of the fluid; c_p ($\text{J kg}^{-1} \text{K}^{-1}$) is the specific heat of the fluid; A (m^2) is the collector glass cover area; I (W m^{-2}) is the intensity of solar irradiation; T_{in} ($^{\circ}\text{C}$) is the inlet fluid temperature; T_{out} ($^{\circ}\text{C}$) is the outlet fluid temperature; η is the thermal efficiency of a collector; F_R is the collector heat removal factor (less than 1.0); U_L ($\text{W m}^{-2} \text{K}^{-1}$) is the collector overall heat loss coefficient; τ is the transmittance of the glass cover (the fraction of incoming solar radiation that reaches the absorber plate of the collector); α is the absorptance of the absorber plate (the fraction of solar energy reaching the plate surface and being absorbed); and T_a ($^{\circ}\text{C}$) is

the ambient air temperature.

The efficiency goes down when the irradiance and the air temperature go down, and the inlet water temperature goes up. This relationship applies to all of the solar collector types listed above except for a parabolic dish type. An efficiency greater than zero means that the output temperature from a collector is greater than the input temperature. When this condition exists for the unglazed array, the water entering the glazed array is effectively preheated, thereby giving a net increase in energy collection for the system and more cost-effective collection. When this condition no longer exists, the efficiency might be effectively negative (meaning that the unglazed array is actually cooling the water rather than heating it). In this case the unglazed array needs to be bypassed (using the three-port valve) since it is doing more harm than good. It is to be noted from Equation 1 that the three parameters above do not need to be specifically known, as long as the inlet and outlet temperatures for the unglazed array are sufficiently known. This is now a system with two different collector types which allows for both high output temperature and a lower total cost for the collectors for a given amount of thermal energy collection.

Notice in Table 1 that the unglazed solar collectors can also be used as air to liquid heat exchangers. This means that a system similar to Figures 1(a) and 1(b) might also serve to collect cold for use in summer season air conditioning. Seasonal storage of cold has been done at various places in Europe such as ICAX and others. The glazed panels in Figures 1(a) and 1(b) will not be very useful for the collection of cold, since the glazing over the panels is specifically designed to prevent this. The cold collection might best be done with the use of a second bypass valve as shown in Figure 1(c). This valve (V2) serves to bypass around the glazed array when cold collection is being done. It is assumed that there will be multiple temperature sensors and a computer to control the two valves.

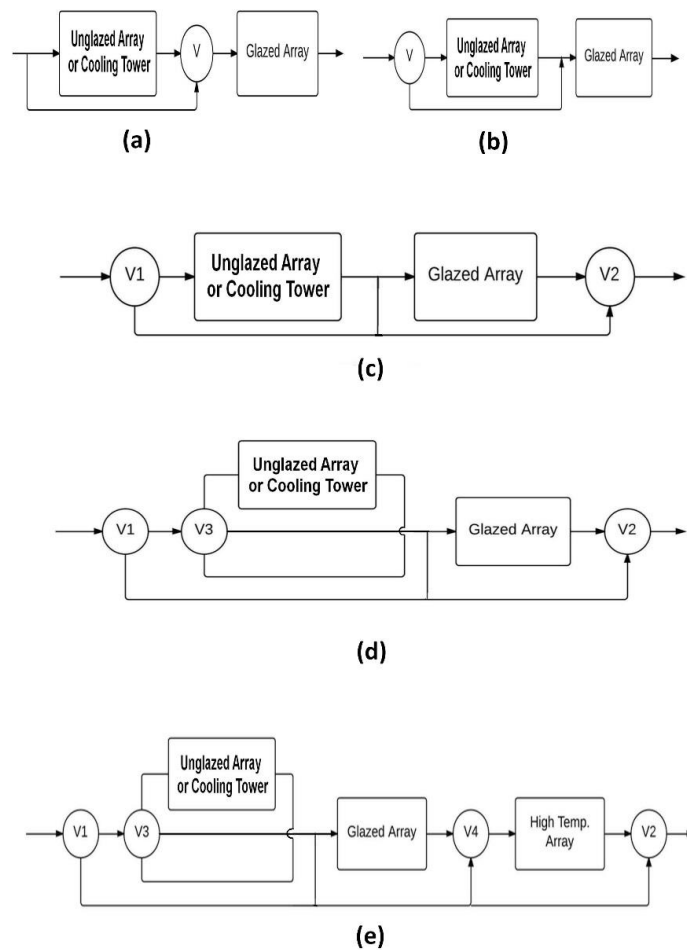

Fig. 1: Multiple Collector Types for either Heat or Cold Collection

Although the discussion up to this point has been about seasonal storage of heat and cold (possibly underground), the system of Figure 2(c) could also be useful on a more short term (or diurnal) basis. For example, for use during the cooling season, a water source heat pump could use cold water stored in a tank and cooled by the unglazed panels at night. This saves energy by boosting the efficiency of the heat pump. Even without a heat pump, there are examples where diurnal cold storage in hydronic floor slabs is used (SolarLogic, LLC in Santa Fe, NM - <http://www.solarlogicllc.com/>). Another option is to use the unglazed panels with a chiller at night to generate ice. The ice can be stored in an insulated container and will provide space cooling during the following day. Short term storage for space heating is also possible, such as with hydronic floors.

The unglazed panels are unique in that they provide four different ways to exchange energy with the environment:

- Direct collection of heat from solar irradiance.
- Convective exchange with the surrounding air.
- Radiative cooling into the night sky.
- Conductive cooling when covered with snow in winter.

All of these methods could apply to the system of Figure 1(c). One shortcoming of Figure 1(c) relates to the situation where the panels are mounted at an angle to the horizontal so that the solar radiation can be perpendicular to the panels at some time in the year. In this case the direction of flow through the unglazed panels should be switched between cooling and heating. For the heating mode, the relatively cool water should enter the panels at the bottom and warmer water should leave at the top (this relates to buoyancy flow due to density changes with temperature). For cold collection, the relatively warm water should enter at the top and the colder water taken from the bottom. This can be accomplished by adding a reversing valve (V3) as shown in Figure 1(d). In some cases (such as a large flat roof) the unglazed panels might be placed flat down on the roof. In this case the reversing valve is not needed.

As a modification of Figures 1(a) through 1(d), the use of other types of solar collectors could be considered instead of the glazed flat panel type. For example, the evacuated tube collector type might give higher temperatures at little added cost. Parabolic concentrator collectors could give even higher temperatures, but with the need for moving parts and perhaps shorter lifetimes.

Another possible improvement in the system would be the use of three collector types rather than two. An example of this is shown in Figure 1(e). The reasoning behind Figure 1(e) is that there will be some conditions of temperature and irradiance such that both the glazed and unglazed panels will have zero efficiency for heating. In this case, one of the other higher temperature collector types (evacuated tube or concentrator) could be used and the flat glazed and unglazed panels bypassed. This is accomplished with one more valve (V4).

The solar thermal panels discussed above are not specifically designed for air to liquid heat exchange. It just happens that the unglazed panels offer this as a secondary use. On the other hand, cooling towers are specifically designed and optimized for this type of use. Considering the major categories of cooling towers, most use water evaporation to assist in the cooling function however one type does not. In the application considered here, the cooling tower should function in a reverse mode in summer (heat transfer from air to liquid), so that water evaporation is not desired. This means that the appropriate cooling tower for use in systems described above will be the dry type. A dry cooling tower (or dry cooler) is functionally similar to an automobile radiator and fan, but on a much larger scale. One or more dry cooling towers can take the place of the unglazed panel arrays in any of the previous figures. A dry cooling tower will be suitable for both heat collection and cold collection. A side benefit of doing this would be a much larger thermal power transfer in a much smaller footprint. This is especially important for installations in cities with limited areas on rooftops or elsewhere. The relative performance and cost of the dry cooling tower approach versus the unglazed solar panel approach will require further study, although both could be used in a single system.

Although all of the flow control elements discussed and shown here are valves, this control could also be done with pumps (preferably positive displacement types). It is assumed that the collection and exchange of thermal energy is a part of a larger system which would require one or more pumps (not shown in the figures), and perhaps one or more thermal storage elements. It is also assumed that there would be sensors of various types such as temperature, pressure, flow rate, etc. along with a computer for control and optimization.

3. Flat Plate Collector for Heat and Cold

As a simplification of the concepts above, it may be possible to modify a flat plate solar thermal collector so that it is efficient for collection of both heat and cold. In this way the separate blocks for unglazed and glazed collectors in Figure 1 could be combined. A specific way to do this is shown in Figure 2.

Figure 2 shows the addition of a second pane of cover glass with a hollow space in between the panes such that fluid such as water or antifreeze solution can flow in this space. This sandwich of panes can be made stronger and able to withstand moderate pressure with the addition of spacer strips in between the panes. The spacer strips would be oriented in the flow direction (generally from top to bottom for cold collection) and would be small enough so that the obstruction of flow is minimized. Figure 2(a) shows a simplified cross-sectional view, and Figure 2(b) shows an exploded view. Figure 2(b) also shows the use of two check valves to control the flow direction for either heating or cooling. These two valves allow for a single pair of pipes to transfer fluid from the collector to the point of use. Without valves of this sort three or four pipes may be required. The concept of Figure 2 is similar to research on windows for buildings in Europe with a project called Fluidglass (www.fluidglass.eu). This project is supported by the European Union and has contributors from many different countries. Optimization of dimensions and material for the Fluidglass project may also apply to the modified solar collector described above.

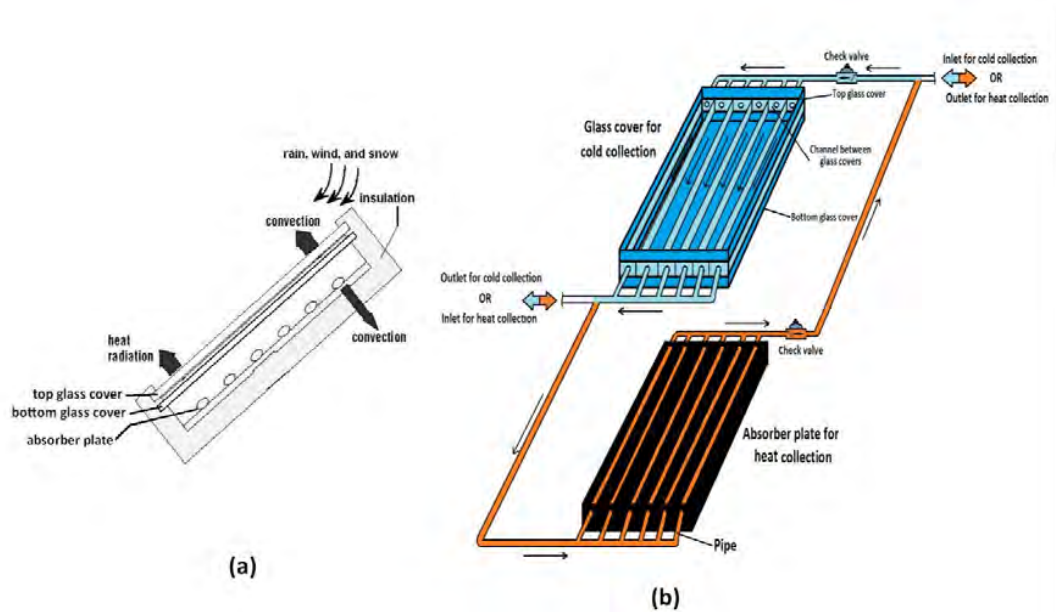

Fig. 2: Flat Plate Collector for Heat and Cold

Another consideration is how to use this collector design for maximization of solar heat collection. Two options for this are as follows:

- Option 1: when solar heating is desired, drain all of the cold collection liquid out of the collector so that the glazing becomes a double pane insulator.
- Option 2: keep the cold collection liquid (possibly water) in the collector at all times, including times for solar thermal collection.

There are pros and cons for each of these options. Option 1 gives a higher efficiency for very high temperature entrance water and low solar irradiance. Option 2 gives a higher efficiency for the opposite situation because of fewer glass to air reflective surfaces, and it avoids the extra cost and complexity of a system to control the drainage and subsequent replacement of water in the collectors. In any case, there may be some advantage to at least have these two choices, which are not present with any other type of solar thermal collector.

4. Hybrid Heat Pump Systems

Hybrid (or multisource) heat pump systems typically use a single three-port valve to improve the performance of ground source systems as shown in Figure 3. The valve allows for a series connection of two elements of heat exchange and it also allows for one of these elements to be bypassed.

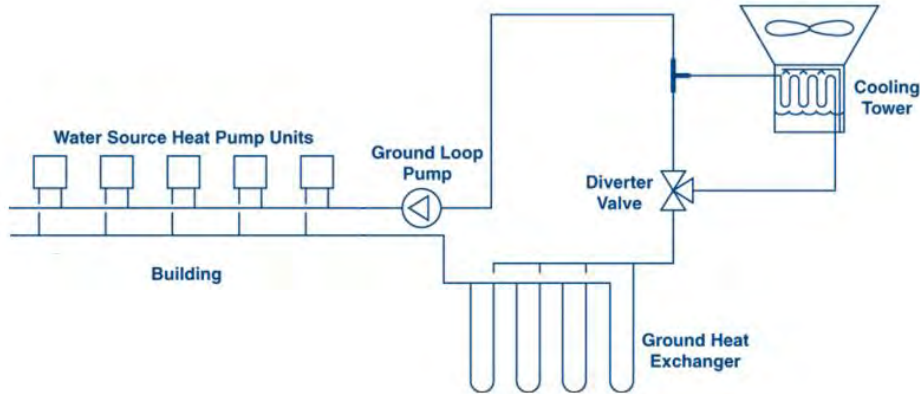

Fig. 3: Typical Hybrid Heat Pump System (DOE/EE, 2001)

Figure 3 shows a cooling tower as the above-ground heat exchange element, however this could instead be an array of solar collectors for either heat or cold collection. Notice that the direction of pump flow is from right to left in this example, which indicates a counterclockwise flow around the loop. There may be reasons to have the cooling tower placed ahead of the ground exchanger in the flow path (depending on climate zone or temperature conditions). This is not possible in Figure 3. It may also be desired to place the cooling tower in parallel with the ground exchanger or perhaps use the cooling tower in the system without any flow in the ground exchanger. These various modes are not allowed in Figure 3 however they are enabled with the use of more valves as shown in Figures 4 and 5.

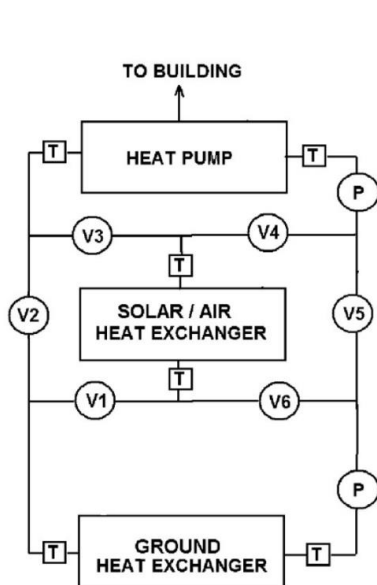

Fig. 4: Six Valve Heat Pump System

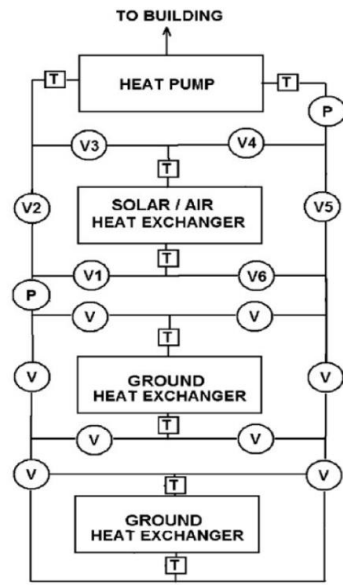

Fig. 5: Dual Ground Exchanger HP System

The six valve system in Figure 4 allows for 10 different modes of functionality, depending on which valves are open and which are closed. For example, if flow is excluded from the solar/air heat exchanger, the system is in a ground source mode. If flow is excluded from the ground heat exchanger, the system is in an air source mode with the possible added benefit of solar heating. Figure 4 also allows for the ground to be preconditioned seasonally either with or without flow through the heat pump. For cooling dominated climates, the coldness of

winter nights can be used to cool the underground heat exchange region. For heating dominated climates, the summer sun can be used to place heat into this region. Figure 5 allows for two separate regions underground, each of them having the use of the 10 modes of Figure 4. The expectation is that if one region is kept permanently warm and another region permanently cold the heat pump will always be more efficient than for the case where the ground is at a single temperature all the time. Even worse is the case where the ground becomes either too hot or too cold to be useful for space conditioning. Figures 4 and 5 show the use of temperature sensors and pumps indicated with the letters T and P respectively. The concepts shown in Figures 1 and 2 could be used in the solar/air heat exchanger block of Figures 4 and 5.

The systems above can be used with any typical form of underground heat exchange method (boreholes, slinky systems, etc.) however for the case of long term thermal energy storage, better designs are possible. Perhaps the best design is a modified form of the horizontal array mentioned with respect to ICAX in England. There are at least three improvements that might be used: a spiral shape for the pipe array, a highly conductive material around the pipes, and a “soaker hose” perforated pipe array to add moisture to the ground. Three versions of horizontal spiral pipe arrays are shown in Figure 6. Figure 6(a) is the simplest concept with just a single flow path from center to edge. Figure 6(b) shows two flow paths in parallel from center to edge, which could reduce the pump power required. More than two paths could also be considered, this being one of many parameters to be optimized. If the array is to be placed under a building, a rectangular shape could be used as in Figure 6(c), to match the dimensions of the building.

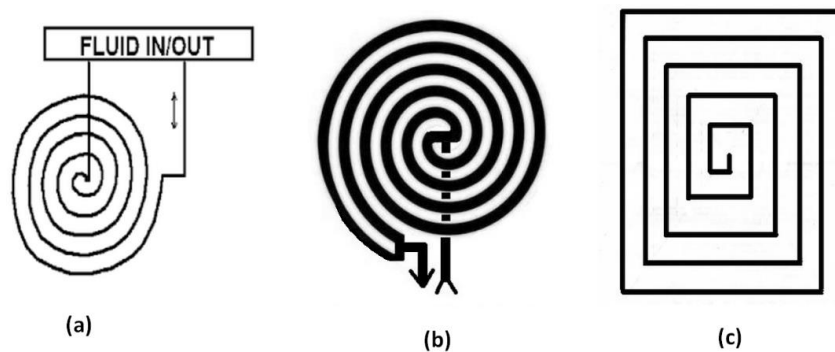

Fig. 6: Horizontal Spiral Pipe Arrays

The reason for the spiral shape is to always have the most extreme temperature at the center of the thermal storage region. This leads to an approximate hemispherical shape for the isothermal surfaces underground. A hemisphere with insulation at the surface gives the maximum possible ratio between volume and surface area, and also gives the maximum ratio between energy stored and rate of heat loss to the surroundings. Another assumption (for cost reasons) is that insulation is only at the top, not along the sides or the bottom. This is consistent with the Drake Landing Solar Community design and the designs from ICAX in England. A second improvement to be considered is to cover the pipes in the array with highly conductive material such as grout or concrete. For purposes of heat exchange, concrete around horizontal pipes has been used by Enercret GmbH in Roth, Austria (www.enercret.com). The reason for this is the same reason that grout is used in boreholes. It gives a more complete and effective thermal transfer from the pipes to the ground below in comparison to dry dirt or sand. A third possible improvement is to purposely introduce water into the ground just below the pipe array to keep the ground permanently damp and thereby more thermally conductive. This will be a replacement for the normal moisture from rain that is diverted away by the insulation at the top. Also, there will likely be an impervious plastic cover at the top surface of the insulation to assure that the insulation performance is not degraded by moisture. The array to introduce water may be similar to the perforated pipe drain fields in septic systems.

5. Simulation Results

Results from simulation studies of the underground storage are shown in Figure 7. The assumptions going in to this figure are that there is a heated hemisphere below a large area surface insulator with ground thermal characteristics as listed at the bottom right corner of the figure. To approximate a seasonal time frame, there is a heating (warm-up) time of 60 days followed by a 150 day cool down time. During this 150 day period, a certain

fraction of the initial heat will be lost to the surrounding ground. For a 4 meter heated radius about 85 percent of the initial heat is lost. On the other hand, with a 15 meter heated radius, only 20 percent of the initial heat is lost. Since this design does not provide a perfect hemisphere for the isothermal surfaces, these numbers should be considered only as ballpark approximate. Another consideration is that some types of solar thermal collectors such as evacuated tubes can provide significant heat whenever the sun shines, so a span of 150 days with no heat added to the system may be overly pessimistic. More complete simulations and optimization studies are underway.

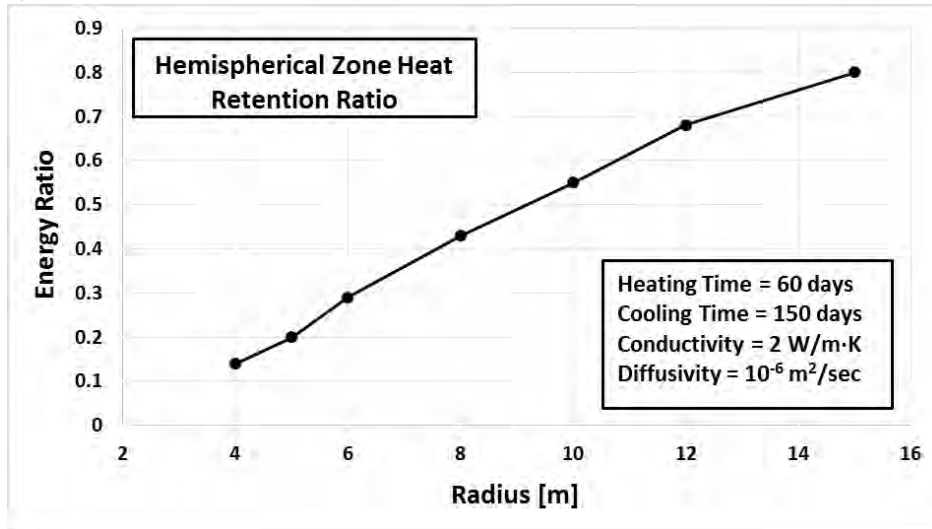

Fig. 7: Simulation Results

6. Summary and Conclusions

A variety of ideas have been described here that may be applied for specific building types and specific heating and cooling needs. These ideas may not have much advantage for an HVAC retrofit of a small house surrounded by trees. On the other hand, new construction of a one or two story office or apartment building with an adjacent parking lot would be a very good fit. A general concept would involve the ground under the parking lot, under the building, and space on the roof. Assuming that the building needs both heating and cooling, the ground beneath the parking lot could be for cold storage and the ground under the building for heat storage. A nearly ideal case would be a black asphalt parking lot surface with low visible light reflectivity (efficient collection of solar heat). With a horizontal pipe array just below the asphalt surface, the parking lot becomes both a solar thermal heat collector and also an effective winter or night time cold collector. The pipe array near the surface of the parking lot does not need to have a spiral shape. A few inches below the parking lot collection array there would be a layer of rigid insulation. Below the insulation there would be a spiral array for cold storage. Below the building there would be a similar layer of rigid insulation and below the insulation a second spiral array for heat storage. A reason for heat rather than cold under the building is to avoid frost heave damage to the foundation of the building. To obtain high temperature for heat storage there could be glazed or evacuated tube solar collectors on the roof. The connection between the parking lot collection and the collectors on the roof could be as shown in Figure 1(c) or 1(e) above. For a very cold climate region it could be better to use both underground regions for heat storage. For a very warm climate region or a building with large internal heat, both underground regions could be used for cold storage. A side benefit in having both hot and cold fluid available is the possibility to generate electricity using organic Rankine cycle generation (Organic Rankine cycle, 2016).

What is presented above is intended to be a very preliminary design concept. Many parameters remain to be studied and optimized. For example, the thickness of the insulation layer (or layers) will involve a tradeoff between cost and transfer of heat between the underground and the atmosphere or the underground and the building. Another interesting question is whether a heat pump is needed or not for a specific building design. For a building that adheres to many passive house principles with hydronic floor heating and radiative or chilled beam cooling it is possible that the HVAC design could avoid the heat pump and just use water pumps, valves and a control computer. This might be a significant savings in initial cost and also provide a building that would use essentially no fossil fuel for HVAC.

7. References

- Good C., Goia F., 2016. Integrated ground source heat pumps and solar thermal systems for zero energy buildings. CLIMA 2016 - proceedings of the 12th REHVA World Congress: volume 3. Aalborg: Aalborg University, Department of Civil Engineering.
- Hesaraki A., Holmberg S., Haghighat F., 2015. Seasonal thermal energy storage with heat pumps and low temperatures in building projects – A comparative review. *Renewable and Sustainable Energy Reviews*. 43,1199-1213.
- Peau, Thibault Quentin; Gennari, Luca; Olesen, Bjarne W., 2015. Nighttime radiative cooling potential of unglazed and PV/T solar collectors: parametric and experimental analyses. *Proceedings of the 8th Mediterranean Congress of Heating, Ventilation and Air-Conditioning (CLIMAMED 2015)*.
- Man Y, Yang H, Spitler JD, Fang Z., 2011. Feasibility study on novel hybrid ground coupled heat pump system with nocturnal cooling radiator for cooling load dominated buildings. *Applied Energy*. 88,4160-4171.
- Xu X., Niu R., Feng G., 2015. An experimental and analytical study of a radiative cooling system with flat plate collectors. doi:10.1016/j.proeng.2015.09.180. The 9th International Symposium on Heating, Ventilation and Air Conditioning (ISHVAC) joint with the 3rd International Conference on Building Energy and Environment (COBEE), 12-15 July 2015, Tianjin, China
- Seasonal thermal energy storage (STES). 2016. https://en.wikipedia.org/wiki/Seasonal_thermal_energy_storage. Accessed June 22, 2016.
- Drake Landing Solar Community (DLSC) brochures. 2016. http://www.dlsc.ca/DLSC_Brochure_e.pdf. Accessed June 22 2016.
- Carder DR, Barker KJ, Hewitt MG, Ritter D., Kiff A., 2007. Performance of an interseasonal heat transfer facility for collection, storage and re-use of solar heat from the road surface. Project Report PPR 302. TRL Limited. November 2007.
- DOE/EE-0258, 2001. Assessment of hybrid geothermal heat pump systems. Federal energy management program. <http://www.eren.doe.gov/femp>.
- Organic Rankine cycle. 2016. https://en.wikipedia.org/wiki/Organic_Rankine_cycle. Accessed June 22, 2016.

SANE - Forum



The Spartan Superway: A Solar-Powered Automated Transportation Network

Burford J. Furman¹

¹ San José State University, Department of Mechanical Engineering, San José (USA)

Abstract

Since 2012, more than 200 undergraduate and graduate students, mostly from San José State University, but including other domestic and international institutions, have been driving innovation in the development of solar-powered automated transit networks (ATNs) through the Spartan Superway project.

Functional models at full and partial scales of a solar-powered, suspended-vehicle ATN have been constructed and demonstrated in public exhibitions.

Research and development continues toward developing a fully-operational test track as well as planning for implementation in the Silicon Valley.

Keywords: *Automated Transit Networks (ATN), pod cars, solar PV, sustainable transportation, engineering education*

1. Introduction

In 2012, the confluence of a new effort in the Department of Mechanical Engineering at San José State University to address sustainable mobility and a search for an interdisciplinary senior project led to the formation of a team of engineers, business, and urban planning students focused on designing a solar powered automated transit system for the Solar Skyways Challenge (Solar Skyways Challenge, 2010). The Challenge offered a \$10k prize for multidisciplinary teams to design, build and improve solar-powered, personalized, Automated Transit Networks (ATN's) and their vehicles (podcars). The students named their effort the 'Spartan Superway', which combines the name of the mascot for SJSU and the elevated, superior features of a new form of sustainable transportation. The project has continued beyond the competition, and the subsequent four and a half years have garnered increasing student interest and involvement as well as international attention. Significant progress has been made toward realizing the goal put forth in the Challenge.

The sections below will describe the features of the Superway system, progress to date, and reflections on involving students in its development.

2. Automated Transit Networks

The concepts embodied in ATN or podcars are not new, but it has only been relatively recently that new design approaches using solar PV for powering the system have been introduced, such as shown in Figure 1 (James, 2004). Donn Fichter, while a transportation graduate student, described the basic ideas of ATN in 1953 and in 1964 published his ideas for a complete automated transportation system integrated into a city (Fichter, 1964, 1968, 1974).



Figure 1: Solar Powered Automated Transit (ATN). Relatively small vehicles traverse a network of exclusive guideways and utilize off-line stations to provide on-demand, non-stop, origin-to-destination mobility. Suspending the ATN vehicle below the guideway makes the upper surface available for PV panels that can power the system. (Jpods system, from (Wilmott, 2015)).

The Advanced Transit Association (ATRA) has provided a widely accepted description of the basic concepts of ATN (ATRA, 2003):

1. Direct origin-to-destination service with no need to transfer or stop at intermediate stations
2. Small vehicles available for the exclusive use of an individual or small group traveling together by choice
3. Service available on demand by the user rather than on fixed schedules
4. Fully automated vehicles (no human drivers) that can be available for use 24 hours a day, seven days a week
5. Vehicles captive to a guideway that is reserved for their exclusive use
6. Small (narrow and light relative to LRT and BRT) guideways usually elevated but also at or near ground level or underground
7. Vehicles able to use all guideways and stations on a fully connected network

Items 1, 5, and 7 deserve additional emphasis. In most depictions (and implementations) of ATN, the guideways are elevated above grade as shown in Figure 1. This is extremely important in that vertical space, as opposed to additional horizontal space, can be utilized to situate an entirely new form of transit in an urban setting without needing additional land. The use of elevated guideways has an important advantage over the current transit paradigm in that transit machines are separated from humans that are not using them, i.e. pedestrians, bicyclists, etc. This results in vastly improved safety and quality of life for urban dwellers. And in contrast to other forms of rail-based transit, ATN uses a network of guideways with off-line stations as opposed to a line corridor where stations are on the line and trains make multiple starts and stops between origins and destinations (see Figure 2). With a network, trips can be diffused throughout an urban area instead of needing to congregate travelers at stations along a single corridor, which adds the need for parking at the station and leads to congestion. With off-line stations, vehicles stop only at origin and destination stations, which leads to savings in energy usage and improved throughput.

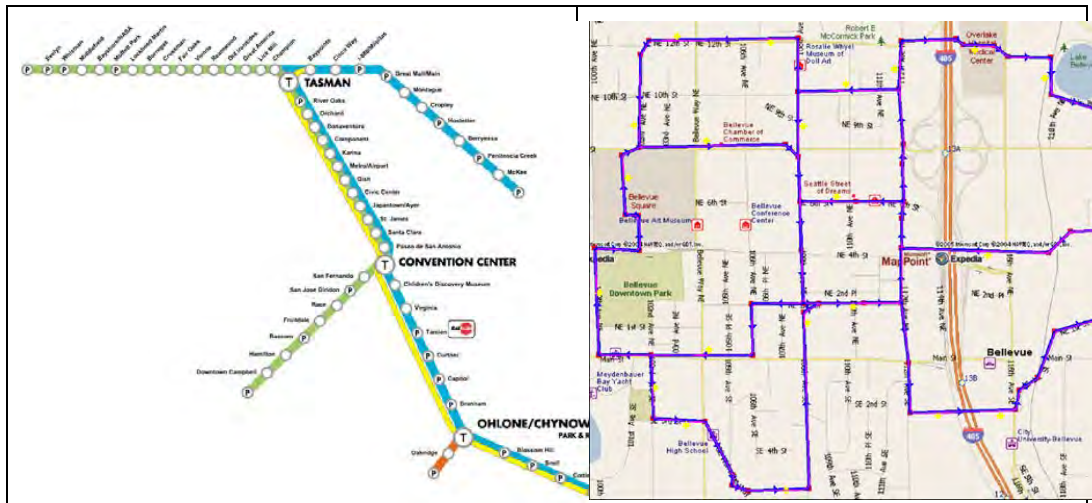

Figure 2: Line haul vs. ATN transit. Conventional rail-based systems have stops arranged along corridors, which requires travelers to get to the corridor to initiate a trip. ATN uses a network and can diffuse travel throughout an area. (Light rail map from <http://www.vta.org/getting-around/interactive-light-rail-map> and ATN network from (Schneider and Raney, 2005)

There are about five systems throughout the world that qualify as ATNs (Furman, et. al., 2014):

- The Morgantown PRT at West Virginia University (1975)
- The Parkshuttle Rivium metro-feeder outside Rotterdam (1999)
- The Masdar City PRT in Abu Dhabi (2010)
- The Terminal 5 shuttle at London Heathrow Airport (2011)
- The nature park shuttle in Suncheon Bay, South Korea (2014)

(The dates in parenthesis indicate when the systems began carrying passengers.)

Despite the fact that the concept of ATN has been around for more than 50 years and that several systems are in operation, there is only what can be described as a ‘proto-market’ for such systems and a relatively small number of suppliers who are capable of delivering a modest system of somewhere between 5 to 20 stations within two to three years from the start of construction (Furman, et. al., 2014). There are a variety of reasons for the current ‘stalemate’, one of which pertains to the state of design of ATN systems. One can liken the situation to the state of wireless communication before the iPhone – a compelling design case has yet to emerge that will spark widespread adoption of ATN and lead to sustainable urban transportation. The Spartan Superway is a more compelling design case for sustainable transportation and is progressing by engaging students to lead the way.

3. Features of the Spartan Superway

The Superway system features vehicles suspended from a relatively slim guideway, which will carry approximately four to six passengers. The suspended approach, in contrast to the more common supported approach (where vehicles ride like a car in a single lane with lateral curbs) is superior from a design standpoint in many aspects, however it is more difficult to implement (see Figure 3). For example, suspending the vehicle from the guideway enables the bogie (the propulsive assembly that rides along the guideway and connects to the vehicle) to be enclosed by the guideway and therefore be protected from accumulating debris, snow, or ice. Dynamically, the ability of a suspended vehicle to swing outward like a pendulum when traversing a curve means that passengers will experience greater ride comfort than would be experienced in a supported vehicle where coming results in the passenger being pressed against the side of the vehicle. As mentioned earlier, by suspending the vehicle below the guideway, the surface above the guideway is available for mounting PV panels. The guideway and bogie designs for Superway follow the

lead of Bengt Gustafsson, CEO of Beamways, A.B., a Swedish ATN developer. Bengt patented an idea for the track and bogie that elegantly solves problems that are inherent in other suspended design approaches and leads to a guideway that is smaller in cross section, lighter, and consequently less costly (Gustafsson, 2014).



Figure 3: Supported vs. Suspended ATN vehicles. The Morgantown PRT on the left is a ‘supported’ system, where vehicles ride on top of the guideway and are supported by it. The Beamways system on the right depicts a suspended system where the vehicle hangs beneath the guideway. (Morgantown photo from <http://www.progressiveengineer.com/PEWebBackissues2002/PEWeb%2024%20Mar%2002-2/24photos/PRT1.jpg>. Suspended vehicle rendering from Beamways, http://www.beamways.com/wp-content/uploads/beamways_system_en.pdf)

Figure 4 shows prototype demonstration models of the Superway bogie and guideway. A common feature in all ATN vehicles (whether supported or suspended) is that the steering mechanics are part of the bogie/vehicle and the guideways have no moving elements. This is in contrast to common rail transit and monorails where switching from one track to another is accomplished by movement of a track element. ATN vehicles can thus accomplish a switching maneuver more rapidly than common rail vehicles, and can therefore operate at shorter ‘headways’ (vehicle separations), which improves vehicle throughput.



Figure 4: Full-scale demonstration models of the Superway guideway and bogie. The photo on the left (from Maker Faire 2014) shows the bogie supporting a mock (not full-scale) vehicle on a short length of straight guideway. The photo on the right shows the bogie and steering mechanisms on a section of guideway that includes a ‘Y’ switching section. The model on the right, from the exhibit shown at Maker Faire in 2015, demonstrated the steering mechanism and the ability for the bogie to navigate both directions of the ‘Y’.

Solar PV mounted on the guideway and tied to the utility electrical power grid makes it feasible to collect all the energy needed to power the system for 24/7 operation. For example, students from Uppsala University studied the feasibility of solar-powered ATN for a 3.8 km network having 10 stations in the city of Uppsala, Sweden. They found that even at that relatively northern latitude ($60^\circ \equiv$ Anchorage Alaska!) a 2420 kWp system consisting of 17,384 m² of PV approximately 7 m wide would be sufficient to provide all the power needed by the system over a year. Preliminary results from our research on a proposed 14 km guideway network in San José shows that a monocrystalline PV canopy approximately two to three meters wide above

the guideway would be sufficient to provide net-zero metered 24/7 operation averaged over the year (conservatively) for 1,440 passengers per hour (assuming 2 passengers per vehicle and 5 second headway between vehicles). Figure 5 shows the proposed network. Details of the analysis are given in Branco, et. al., 2016.

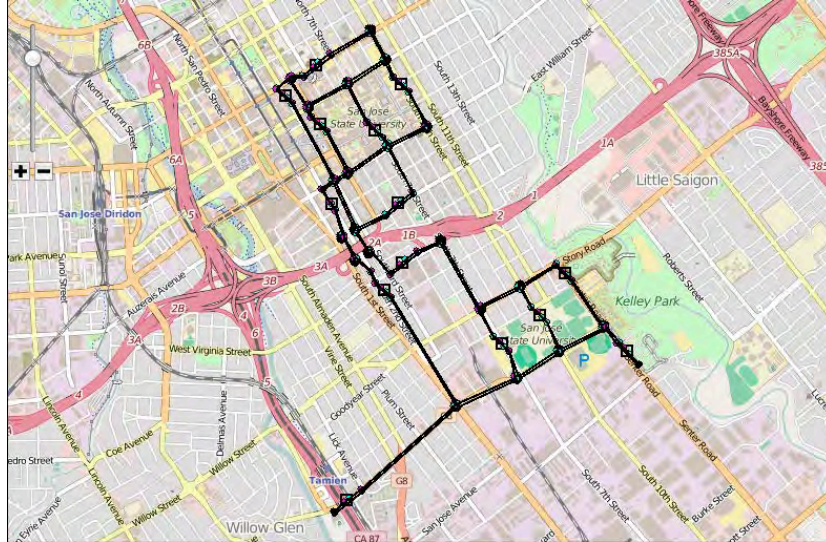

Figure 5: Proposed guideway placement for the Superway in San José. The layout of guideways and stations connects the south and north parts of San José State University and the Tamien Caltrain/Light Rail stations. The total length of the guideway is about 14 km. A canopy of monocrystalline PV approximately two to three meters wide above the guideway would be sufficient to power the system. (Route map made using RouteTime software from Jpods (<http://www.jpods.com/tools>))

The vehicles in the Superway will pick up power from wayside power rails mounted within the guideway and will only carry relatively small batteries for emergency needs.

4. Progress in Development

The following provides a summary of the development of the Spartan Superway since 2012.

2012-2013

In this inaugural year, the team consisted of 11 mechanical, 4 computer, 3 business, and 1 urban planning student (See Figure 6). In addition to winning First Place in the Solar Skyways Challenge prize for its entry, the team designed and fabricated a 1/12 scale model test track, control system, and articulated transit supportive land use metrics and land use entitlements process for implementing ATN. More information on the development from this year can be found in Kipping (2013).

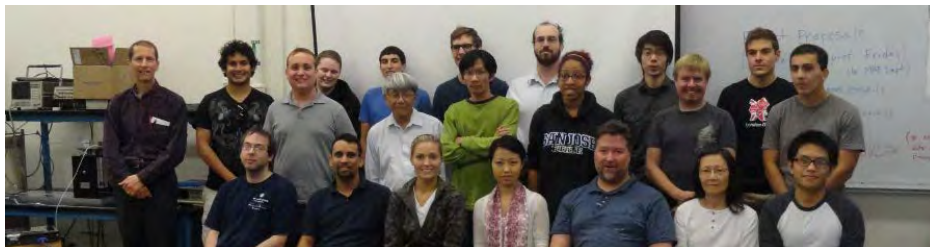

Figure 6: Year 1 (2012-2013) team.

2013-2014

The team expanded to 15 mechanical, three electrical, two civil, two urban planning, and also several dozen industrial design students through the DSID 125 and DSID 131 classes (See Figure 7). The engineers

designed and constructed a 4.9 m section of guideway at full scale with a movable bogie (See Figure 4, left side) and improved the 1/12 scale model with more reliable and more sophisticated vehicles. The guideway, bogie, and 1/12th scale model were demonstrated at Maker Faire Bay Area 2014 and InterSolar 2014. The industrial design students in DSID 125 made full scale mockups to explore what a transit vehicle and ATN station *could* look like, and those in DSID 131 researched use cases and designed smart phone user interfaces (UIs) for transit users. More information on the development from this year can be found in Cowley, et. al., (2014).



Figure. 7: Year 2 (2013-2014) (mechanical) team.

2014-2015

The team continued to expand this year with 26 mechanical, two computer, and one civil engineering student(s) (See Figure 8). Notable accomplishments this year included a full-scale guideway with an operational switch and motorized bogie, which was able to autonomously demonstrate the switching action of the bogie between two guideway paths; a new 1/12th scale model that more closely matched the guideway and bogie of the full-scale than the previous year's design; and a full-scale mockup of a cabin (lower-half); and revised solar PV on the full-scale guideway. The models were shown at the Maker Faire Bay Area 2015 and the S.T.E.A.M. Fest 2015 (1/12 scale only) in San José. In the summer of 2015, our summer intern program expanded greatly with seven students from Brazil, four from Sweden, six from South Korea, two from France, and six from the U.S. (See Figure 9). More information on the development from this year can be found in Ornellas, et. al., (2015).



Figure. 8: Year 3 (2014-2015) (mechanical) team.



Figure. 9: Superway Summer 2015. Students from the U.S., South Korea, France, Brazil, and Sweden participated.

2015-2016

This past year saw the largest team so far with 42 mechanical, three electrical, two MS mechanical, and two MS software engineers (See Figure 10). Nine sub-teams completed: a 1/2-scale guideway and bogie; significant expansion and improvement of the 1/12 scale model and vehicles; a 1/2-scale cabin model and small scale cabin interior model; and made a start at validating finite element analysis of the guideway with physical torsion testing. The two MS software engineers worked on a functional user interface for a smart phone app for a user to schedule and pay for a trip on Superway. The 1/2-scale model was notable in that it demonstrated a switch and had a section of guideway that would enable the vehicle to come down to ground-level by traversing guideway slopes of 17° . The 1/2-scale cabin was suspended from the bogie with an active suspension, which was designed by one of the sub-teams. More information on the development from this year can be found in Alvarez et. al., (2016).



Figure. 10: Year 4 team (2015-2016) (mechanical and electrical teams).

Summer 2016

This summer we have about 30 interns from Brazil, France, South Korea, and SJSU working on improvements to the bogie from Year 4; site planning for a full-speed test track; route planning for actual implementations of Superway at the south campus of SJSU and network routes that would connect the north and south campuses; and PV sizing analysis for the test track and north-south networks (See Figure 11). Also, related work is being done under the umbrella of the SJSU Center for Service Systems Engineering

(CSSEI) to investigate the impact Superway could have on reducing automobile trips in Silicon Valley. More information on CSSEI is available at: <http://cssei.com/>



Figure. 11: Summer 2016 intern team (partial).

5. The Superway as a Student Project

Students have a unique and effective role to play in bringing solar-powered automated transit into widespread use. As mentioned earlier, the Superway project has continued for the last four and a half years as an interdisciplinary senior project. There have also been a handful of graduate students who have done their MS project/thesis on topics that have advanced Superway technology, and we have run a summer research internship program since 2014 with international and domestic students. Some things we have observed over the years in working with students:

- Students resonate with the goals of solar-powered ATN and its interdisciplinary nature

Students understand the mess we are in when it comes to transportation issues, climate change, and environmental impacts, and they are motivated to do something to solve the problems. They also enjoy working with and learning from peers in other disciplines as these bring different perspectives and different skills to the party.

- Students bring a fresh perspective to solving problems

Lacking prior experience means that students can bring fresh, unencumbered thinking to solving technical problems. One phrase we often repeat in describing the work we are doing with students on Superway is that we are ‘raising the bar’, which means that if a group of inexperienced students can demonstrate that something can be done, then certainly more experienced professionals or commercial enterprises will need to step up their game and deliver ATN technology that can at least perform as well.

- Students respond to specific challenges

For the past three years we have set the goal for the students to display their work at Maker Faire Bay Area, a weekend festival that celebrates arts, crafts, engineering, science projects, and the Do-It-Yourself (DIY) mindset. More than 50,000 people attend Maker Faire, so the students are motivated by a deadline and to get their design in good shape to show to the public.

- Students can accomplish a lot with a little

On the one hand, having very modest resources is limiting in terms of what can be designed, purchased, and fabricated, however, on the other hand, it provides opportunity to develop resourceful and creative thinking to “do more with less” as the great technology visionary Buckminster Fuller admonished. Having limited resources also provides students the opportunity to learn how to go about finding the resources they need, which is a valuable skill in itself.

- International and summer interns can be very effective

During the regular school terms, the students working on Superway do so as part of a regular, two-semester, three-unit course. Most SJSU students work part-time in addition to going to school full-time, so they have limited time to put toward the project, perhaps 10 hrs/week at best. During the summer, however, through our intern program, participants spend more like 20 – 30 hrs/week, and their work output is much greater. For the last three summers we have had interns from Brazil (through the Brazil Scientific Mobility Program (BSMP)), Sweden, South Korea, and France.

- ATN development can and should engage disciplines outside of engineering

Creating a new paradigm of truly sustainable is not just a task for engineers! Urban planners, business, industrial designers, architects, economists, and many other disciplines are needed to fully realize the goal of solar powered ATN. There is currently a lot of emphasis in academia on providing students with interdisciplinary projects. ATN development is a great way to meet this need.

There are challenges, however, when working with student, and we continue to look for approaches to overcome them. For example:

- It's hard to maintain continuity from year to year with 100% turnover

One of the most difficult aspects of working with students is that we only have them for a limited time. Every academic year we start with a new group that has only limited, informal connection to the group who came before. Much time is spent at the outset of the year getting the new students ‘up to speed’ and helping them set up organizational and managerial structures under which to carry out their work.

- There is a significant learning curve at the start of the term

Going along with the previous challenge, we find that it takes quite a bit of time at the beginning of the term to get the students oriented to ATN and cognizant of the work of prior teams

- Our teams are composed of students with a range of abilities and work ethics

Unlike a company, which has the luxury to hire employees on the basis of their skills and experience for a specific position, we have little leverage to exclude students who have interest, but may lack the skills and experience that would enable them to be effective early on. Consequently, we usually field a team with a wide range of abilities and work ethics. It is hard to discern at the outset who will be the key contributors, the average, or the slackers, and this causes variability in the quality of the outcome from year to year.

- Knowledge capture, transfer, and progress tracking are tricky

We are making more use of cloud storage, such as Google Drive, to capture and make available knowledge generated by the teams. One rather new practice we've employed is the use of team and individual blogs (See: <http://spartansuperway.blogspot.com/> and links to student blogs). This has helped us capture knowledge and check on progress of both individuals and sub-teams, which is a challenge when the full team is relatively large. When asked about what would have improved the outcome of the project at the end of the term, we often hear, ‘communication’, from the students. There are significant interdependencies in a project like Superway, and it is hard to coordinate these without a full-time project manager.

6. Conclusions

The Spartan Superway is leading the way toward a new paradigm of urban transportation that is truly sustainable, because it is based on solar power. Students are leading the charge to show what can be done in this regard. Currently, fossil fuel based vehicles all compete for the same constrained space at grade, crash

into each other and into people. The current transit paradigm is tired and in need of radical, not incremental, improvement. The Superway is that improvement. It is now time for institutions and individuals who are really serious about sustainability, climate change, breaking our addiction to petroleum, and improving the quality of life in urban areas to step up and support this work.

7. References

- Advanced Transit Association, Inc. (ATRA). PRT Application Characteristics. Retrieved from <http://www.advancedtransit.org/advanced-transit/comparison/prt-characteristics/>
- Alvarez, R., et. al., 2016. Spartan Superway: A Solar Powered Automated Public Transportation System. Available at: <http://tinyurl.com/jbla3hz>
- Branco, L., Rosenfeld, E., Neto, D., and Furman, B., 2016. Case Study of a Solar Power Installation on an Automated Transit Network in San José, (to be published), ASES National Solar Conference 2016, San Francisco, CA, USA July 10-13, 2016.
- Cowley, A., et. al., 2014. Spartan Superway: A Solar Powered Automated Public Transportation System. Available at: <http://tinyurl.com/hcvl893>
- Fichter, D., 1974. Veyar: Small Cars as the Key to Urban PRT. In Personal Rapid Transit II: Progress, Problems, and Potential of a Promising New Form of Public Transportation, 1973 International Conference on Personal Rapid Transit, Minneapolis, Minnesota, May 2-4, 1973.
- Fichter, D., 1968. Small Car Automatic Transit. Highway Research Record, No. 251, Washington: Highway Research Board, pp. 55-58.
- Fichter, D., 1964. Individualized Automated Transit and the City. BH Sikes, Providence, RI.
- Furman, B., Fabian, L., Ellis, S., Muller, P., & Swenson, R., 2014. Automated transit networks (ATN): A review of the state of the industry and prospects for the future (No. CA-MTI-14-1227). Available online at: <http://transweb.sjsu.edu/project/1227.html>
- Gustafsson, B., 2014. U.S. Patent No. 8,807,043. Washington, DC: U.S. Patent and Trademark Office.
- James, W., 2004. US Patent 6810817 B1, Intelligent transport system.
- Kipping, G., et. al., 2013. SuperWay: A Solar Powered Automated Transportation System. Available from: <http://tinyurl.com/pvx9pnk>
- Ornellas, D., et. al., 2015. Spartan Superway: A Solar Powered Automated Public Transportation System. Available from: <http://tinyurl.com/gnfsqts>
- Schneider, J., Raney, S., 2005. Personal Rapid Transit for Microsoft and Bellevue. Available from: http://www.cities21.org/MS_Bellevue_PRT.pdf
- Solar Skyways Challenge, 2010. Retrieved from <https://www.inist.org/challenge/>
- Willmott, Don, 2015. Invasion of the Pod People. Retrieved from http://www.huffingtonpost.com/x-prize-foundation/invasion-of-the-pod-peopl_b_6882430.html



ASES National Solar Conference 2016

Case Study of a Solar Power Installation for an Automated Transit Network in San José

Leonardo C. Branco¹, Eric L. Rosenfeld,¹ Durval Marques de Queiroz Neto, and Burford J. Furman¹,

¹ San José State University, Department of Mechanical Engineering, San José (USA)

Abstract

The Sustainable Mobility System for Silicon Valley (SMSSV), also known as the Spartan Superway, is a project to develop a grid-tied solar powered Automated Transit Network (ATN) system.

Recent work has focused on analyzing the power requirements and designing the solar power system for a potential implementation of ATN in the city of San José. Extensive use of the System Advisor Model (SAM) software from the National Renewable Laboratory (NREL) has made it possible to estimate how much solar PV is needed to run the system 24/7 and be zero net-metered (on average) over a calendar year.

SAM estimates the number as well the total area of PV needed. Considering losses from shading and soiling, it is possible to predict how much of the POA (plane-of-array) energy will be available for the transportation network and how much can be used for other applications.

Modeling results show that to operate approximately 90 vehicles over the 14 km guideway 24 hours a day requires 19,600 monocrystalline solar panels with an area of 38,300 m².

Keywords: *Automated Transit Networks (ATN), Personal Rapid Transit (PRT), sustainable energy, photovoltaic cells, System Advisor Model (SAM)*

1. Introduction

San José State University started the Sustainable Mobility System for Silicon Valley (SMSSV), also known as Spartan Superway, in 2012. It addresses sustainable mobility through the use of a solar-powered automated transit network (ATN), sometimes referred to as personal rapid transit (PRT) or pod cars. The Spartan Superway solves the problems of traffic congestion, accidents, high vehicle costs, environmental degradation, and significant dependence on fossil fuels for transportation.

The United States Energy Information Agency (EIA) estimated in 2011 that energy sources used in the US were 38.1% oil, 20.8% coal, and 22.9% natural gas - in other words 81.9% of our energy came from hydrocarbons with harmful emissions (EIA, 2011). The objective of the authors' research is to power the Spartan Superway ATN completely using solar energy, drastically reducing the amount of toxic materials, i.e., batteries, fossil fuel, coal, etc., that are used by other modes of transit. The integration of solar power into the Superway encompasses solar panel mechanical design, solar panel orientations and material, relevant energy consumption and production calculations, and the electrical system design.

Progress has been made in: determining the general power consumption for the Spartan Superway, solar

(wayside pick-up). A full-scale test track is being designed, so that the complete system can be validated and refined. The rest of this paper will summarize results of research to date.

2. Sustainable Mobility System for Silicon Valley (SMSSV)

The SMSSV, also known as Spartan Superway, consists of vehicles that are suspended below and move along an elevated guideway above which solar PV panels are attached. It is expected that vehicles will carry four to six passengers. Operation of the vehicles can occur 24/7, because the solar system will be tied to the grid. It is conceivable that vehicles could also be used for material transport when passenger transport is low (such as at night).

Work on this project since 2012 has been carried out by students, primarily from San José State University but also including international students. The groups are divided into teams focused on Bogie, Propulsion, Steering and Braking, Active Suspension, Cabin, Wayside Power, Guideway Structural Analysis, and Power Analysis.

3. Methodology

3.1. Scenario analysis

The initial design case consists of the network shown in Figure 1, that connects the south and north campus locations of San José State University and the Tamien Cal Train and VTA Light Rail stations. Table 1 lists the specifications for the N-S campus network.



Fig. 1: Guideway placement for the SMSSV in San José

Tab. 1: Network specifications

North-South Campus network	
Total length	14.400 Km
Available area	43,200 – 57,600 m ²
Distance between N-S	3500 m
Number of vehicles	85-95
Number of stations	26

Automated transportation networks require control of the spacing of vehicles moving on the guideway. One control approach is known as synchronous moving-cell control. This approach assumes that vehicles travelling along a given link in the network occupy hypothetical slots (Rumsey, 1973). A recent study on ATN for the city of San José done by the Aerospace Corporation found that congestion on the network would occur if the maximum number of slots occupied by ATN vehicles exceeded about 70% of the total number of slots (Paige, 2012). This finding, combined with analysis of data from the University's Park and Ride shuttle (which moves people between a parking lot near the south campus to the north campus), guided the determination of the number of vehicles, which was in turn used to calculate the required energy needed to run the system.

3.2 Power estimation

Equation 1 shows how to calculate the average energy required to move a train of n_T vehicles - a distance D_s over a time duration from $t = 0$ to t_s . The equation is given by (Anderson, 1978):

$$E(t_s) = \frac{1}{\bar{\eta}} \left\{ (1 - R)n_T \frac{M_V V_L^2}{2} + \frac{1}{2} \rho C_D A_V \left[(V_L^2 + \langle V_w^2 \rangle) D_s - \frac{V_L^4}{2a_m} \right] + n_T M_V \left[C_1 D_s + C_2 V_L (D_s - \frac{V_L^2}{3a_m}) + gz \right] \right\} + n_T P_{aux} t_s \quad (\text{eq. 1})$$

Table 2 lists the variables needed in the calculation.

Tab. 2: Variables to account for energy required by a (nT) number of cars to move from t=0 to t_s

Quantity	Symbol	Unit	Quantity	Symbol	Unit
Motor efficiency	η	%	Auxiliary power – Outside required power	P_{aux}	W
Energy recovery factor – Regenerative braking	\mathcal{R}	%	Distance between stops	D_s	m
Number of vehicles	n_T	-	Maximum acceleration		kg m^{-3}
Vehicle mass	M_V	Kg	Road rolling resistance:	C_1 C_2	m s^{-2}
Operational speed	V_L	m s^{-1}		C_2 C_2	s^{-1}
Air density	ρ	Kg m^{-3}	Change in the elevation during the trip	z	m
Coefficient of air drag	C_D	-			
Wind speed	V_w	m s^{-1}			

The velocity profile for a trip cycle is shown in Figure 3:

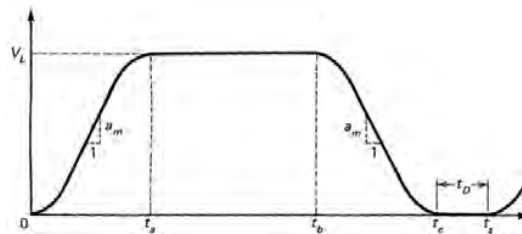

Fig. 3: Station-to-Station Velocity Profile (from Anderson, 1978)

The vehicle begins to move at $t=0$, reaches maximum velocity at $t=t_a$, cruises at constant speed until $t=t_b$, decelerates and reaches zero velocity at t_c , waits at a station a time $t=t_D$ (called the station dwell time), and repeats the cycle. Equation 2 defines the station-to-station time, t_s (Anderson, 1978):

$$t_s = t_D + t_a + (t_c - t_b) + (t_b - t_a) \quad (\text{eq. 2})$$

As this method consider a train of vehicles instead of single cars running along the guideway, the first step is to calculate the amount of energy for $n_T = 1$. Next, the values of energy consumed by air resistance for all the cars as well the road rolling resistance and the energy recovered using regenerative brakes are summed, and this sum is multiplied by the actual number of vehicles running on the guideway.

3.3 Assumptions and System Advisor Model (SAM) Database

The System Advisor Model (SAM), developed by the National Renewable Energy Laboratory (NREL), was used to develop the analysis of the solar power system (<https://sam.nrel.gov/>). The output from SAM shows the total area and number of solar panels needed.

step was to access the weather data from the city of San José to estimate the mean wind speed over the year. To estimate the amount of energy needed to move the car at 13.4 m/s (30 mph), it was also necessary to define the air drag coefficient of the vehicle cabins used on the guideway.

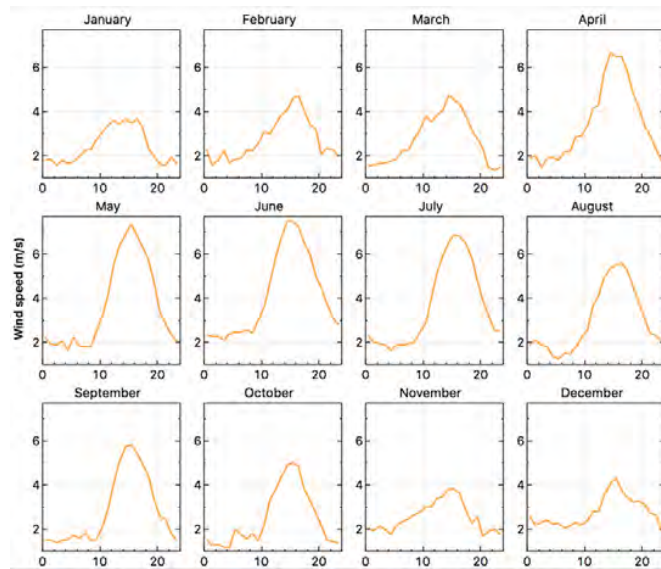

Fig. 4: San José's profile of average wind speed per hour (data from SAM)

Analyzing San José's profile of average wind speed for the N-S network area, a conservative, peak annual wind speed of 9 m/s was assumed. The coefficient of air drag was found using an airflow model in Solidworks, which came out to be 0.65. Surprisingly after verifying all the energy losses for the system, it turns out that 53% of the losses are due to the air drag.

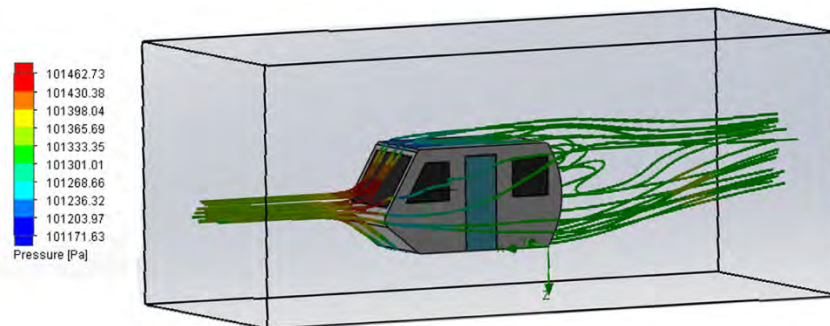

Fig. 5: Airflow model of cabin flow simulation

After considering the aerodynamics of the pod car, it is necessary to verify how much energy will be recovered by a regenerative braking system and how much it is lost by the efficiency of the electrical drive motor. The road rolling resistance was also taken in consideration on this analysis. For simulation purposes, an energy recovery factor of 15%, an electrical motor efficiency of 85%, and the rolling resistance for heavy rail transit (Anderson, 1978) was used in the calculation.

To properly estimate the area of PV required and the number of inverters needed to satisfy the power requirement, three different tracking and orientation approaches were considered. The first one uses a fixed solar panel orientation, the second one uses a single-axis tracker, and the third uses a dual-axis tracker.

4. Results

Using equation 1, the energy consumption of all the vehicles is approximately 28,490 kWh per day, which equates to 10,398,940 kWh per year. The values of the variables used in the calculation are shown in Table 3 below.

Tab. 3: Variables and their values used to calculate the energy consumption of vehicles.

Variable	Value	Unit
Gravitational acceleration	9.81	m/s ²
Auxiliary power	3500	kW
Time	293	s
Efficiency of the motor	0.85	%
Number of vehicles	88	-
Mass (vehicle)	1900	kg
Operating speed	13.4	m/s
Air density	1.225	kg/m ³
Coefficient of air drag	0.51	-
Wind speed	9	m/s
Average distance between stops	3500	m
Maximum acceleration	4	m/s ²
Rolling resistance coefficients		
C ₁	0.0095	N/kg
C ₂	0.0004935	Ns/mkg
Change in elevation	10	m
	Value	Unit
Pod car daily energy consumption	3.97x10 ⁶	J
	13.49	kW
Total vehicle daily energy consumption	28,490.2	kWh
Total vehicle yearly energy consumption	10.40x10 ⁶	kWh

Considering the annual consumption of 10.40 x 10⁶ kWh listed in Table 3 above, calculations determined that a 7045 kW DC PV system would be needed. To get an estimated number of panels required, the panel module was assumed to be a SunEdison SE-R360EzC-4y 360W (18.41% efficiency), and the inverter was assumed to be an Advanced Energy Industries: AE 500NX-HE 480 VAC. Using SAM, and the assumptions just described, the model predicts that 19,600 panels are required, which have a total area of 38,300 m². This could be supplied by using a canopy of panels approximately 3 m wide over 89% of the 14 km guideway network. The total installation cost for the system is estimated to be \$17.4 million as shown in Table 4 below.

Tab. 4: SAM's Photovoltaic Systems Report summarizes the performance of our panels (modules) and Inverters as well as the necessary constraints for our desired array size.

System Advisor Model Report		
	Photovoltaic System	7.0 DC MW Nameplate
Commercial		San Jose Intl Ap, CA
		\$2.46/W Installed Cost
		37.37 N, -121.93 E GMT -8
Modules	Annual Results (in Year 1)	Array
SunEdison SE-R360EzC-4y	GHI kWh/m ² /day 5.0	Strings 1,629
Cell material Mono-c-Si	POA kWh/m ² /day 4.0	Modules per string 12
Module area 2 m ²	Net to inverter 10,778,000 DC kWh	String voltage (DC V) 480.8
Module capacity 360.2 DC Watts	Net to grid 10,403,000 AC kWh	Tilt (deg from horizontal) 30.0
Quantity 19,548	Capacity factor 16.87	Azimuth (deg E of N) 180
Total capacity 7 DC MW	Performance ratio 0.72	Tracking no
Total area 38,235 m ²		Backtracking -
Inverters	Project Costs	Self shading no
Advanced Energy Industries: AE 500NX-HE (3159802-XX)	Total installed cost \$17,354,106	Rotation limit (deg) -
Unit capacity 500 AC kW	Salvage value 50	Shading yes
Input voltage 330 - 600 VDC DC V		Snow no
Quantity 13		Solling yes
Total capacity 6.5 AC MW		DC losses (%) 4.4
DC to AC Capacity Ratio 1.08		
AC losses (%) 1.8		

It is important to note that the analysis above assumes that all panels are at a fixed tilt angle of 30°. If however, a single-axis tracking system was used, this would increase the collected energy by about 17.4% result in a 5815 kW DC system, which would consist of 16,140 panels (31,600 m²) and would save approximately \$2 million in installation cost.

If a dual-axis tracking system was used, the system would collect 20.9% more energy than the fixed tilt system and would result in an array size of 5570 kW DC. This system would have 15,500 panels (30,300 m²). To account for the energy consumption and tracking system installation cost, the Helios tracking system (<http://heliotrack.com>) was assumed. The annual energy consumption of this tracking system is approximately 0.127 kWh for a 1-axis tracker and 0.255 kWh for a 2-axis tracker. Each tracking system consumes 0.6 watts and works for approximately 3 minutes every 8 hours, which equates to 2160 J every 8 hours. SAM's average daylight hours of 9.3 in San José was used to calculate the amount of energy consumed per day per tracking system, and the number of tracking systems needed was calculated assuming one tracking system can move 5 panels. The overall energy consumption of the tracking systems can be satisfied by just an additional panel for a 1-axis system and two additional panels for a 2-axis system.

Tab. 5: SAM's solar panel (module) calculation for a Single-Axis system (left table) and a Dual-Axis system (right table) for the North-South Campus track.

Modules		Modules	
SunEdison SE-R360EzC-4y		SunEdison SE-R360EzC-4y	
Cell material	Mono-c-Si	Cell material	Mono-c-Si
Module area	2 m ²	Module area	2 m ²
Module capacity	360.2 DC Watts	Module capacity	360.2 DC Watts
Quantity	16,140	Quantity	15,456
Total capacity	5.8 DC MW	Total capacity	5.6 DC MW
Total area	31,569 m ²	Total area	30,231 m ²

Development of a test track for Superway is also underway. Assuming a guideway length of 650 m, with one active vehicle moving on the guideway 24 hours a day, the estimated energy consumption per year is approximately 5.32×10^4 Kwh. Assuming 150 m between stops, and the SunEdison SE 360W panel for the PV canopy, the required numbers of solar panels needed to satisfy the daily energy consumption would be approximately 94 to 125 depending on fixed or tracking systems shown in Table 6 below.

Tab. 6: Test track cost analysis comparing a fixed system, 1-Axis system, and 2-Axis system.

Tracking System Energy Analysis	Fixed	1-Axis system	2-Axis system	Unit
% of Optimum	-	22.22%	24.44%	%
Total Energy Consumed by Pod	5.32×10^4	5.32×10^4	5.32×10^4	kWh
Annual Consumption for Helios tracking system	0	.127	.255	kWh
Annual Consumption for Helios tracking system	0	2.45	4.76	kWh
Panel/annual production	4.03×10^2	5.53×10^2	5.69×10^2	kWh
Number of panels to compensate tracking system	0	1	1	-
Number of panels	124	97	94	-
Area of Panels	248	194	188	m ²

In Table 6 above, the annual energy consumption of each tracking system is compensated by just one additional panel. The total cost is the sum of cost of installation and the cost of the tracking system (if applicable). The optimization is found by calculating the % difference between the fixed system's and each tracking system's necessary array size. The total panel area is approximately 248 m² for a fixed system, 194 m² for a 1-axis system, and 188 m² for a 2-axis system. In each case, the required area of panels can fit above the guideway over the length of the test track.

4.1 Solar Energy Production and Losses

As the amount of solar energy available in California varies throughout the year, it is also important to define how Superway will be integrated with the electric grid in the city of San José. It is assumed that the grid will be charged throughout the sunlight hours and power the transit system during non-sunlight hours. Figure 7 shows the expected yearly power generation profile.

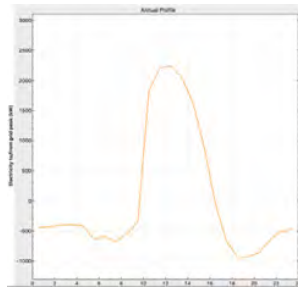

Fig. 7: Annual Profile of Electricity to/from grid peak (kW)

The monthly energy production considering a fixed orientation of the solar panels on the proposed guideway is shown in Figure 8. As expected, the summer months produce the most energy. The grid will receive electricity throughout the sunlight hours and power the transit system during the non-sunlight hours. During the months that the energy produced is not enough to meet all the power requirements, the mobility system will be compensated by the period of the year which there is more energy available.

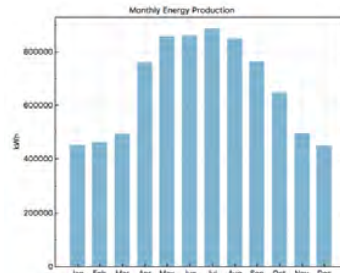

Fig. 8: Monthly Energy Production in kWh

The expected energy losses are related mainly to the efficiency of the selected solar panel, shading, and soiling. The Sankey diagrams generated by SAM below break out the percentage of loss considered in each different tracking and orientation scenario. The maximum percentage of losses due to shading and soiling are about 25% of the nominal Plane-of-Array (POA) (kWh).

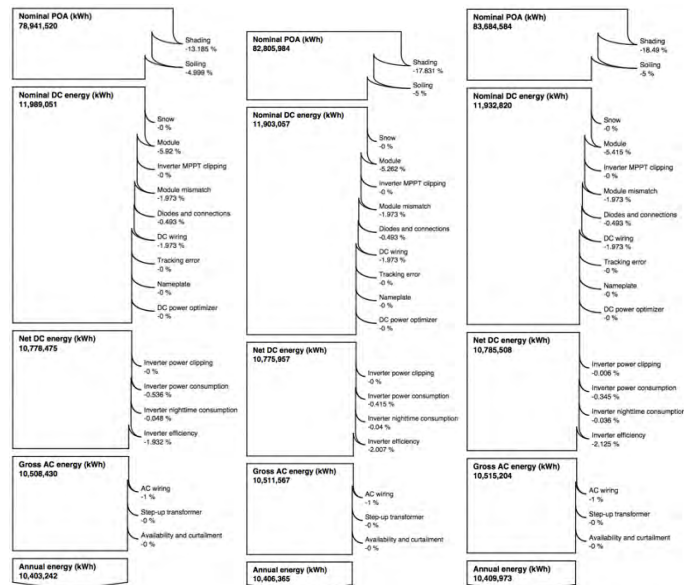

Fig. 9: Sankey Diagram for North South Campus network for three different solar panels tracking options: fixed

4.2 Solar Panel Design

Work is also underway to define concepts for mounting the array and improving the assembly process of the solar panels on the guideway. An important consideration for the whole solar design is to make maintenance be relatively easy.

The first concept design is a module composed of 12 PV panels arranged in an arch and fixed in orientation.

The second initial concept design supports a module composed of three thin-film photovoltaic cells bent into an arched shape. This concept integrates a tracking system that changes the tilt of the modules to guarantee an optimal tilt angle for each season of the year.

The panels have a tilt angle of at least 10° to reduce losses due soiling (Cano, 2011).



Fig. 10: Initial concepts design of the mounting array for the solar panel modules

The optimal tilt angle is a function of the latitude and the season of the year. Landau, 2015, proposed a group of equations to determinate the optimal tilt angle based on how many times during the year the tilt angle is changed.

4.3 Electrical System

Figure 11 shows a block diagram of the hardware and general electrical design. The blue lines show power supplied from the solar panels which will either load the grid or the third rail which supplies power to the vehicles on the guideway. Red dashed lines show power supplied from the city grid to the third rail. Black thick dashed lines represent voltage to motor. Inside the vehicle, the green dotted lines show power flow for regeneration from the motor. Purple dotted lines are for grounding and power return. It important to note the diagram assumes a small system with one solar array and one vehicle.

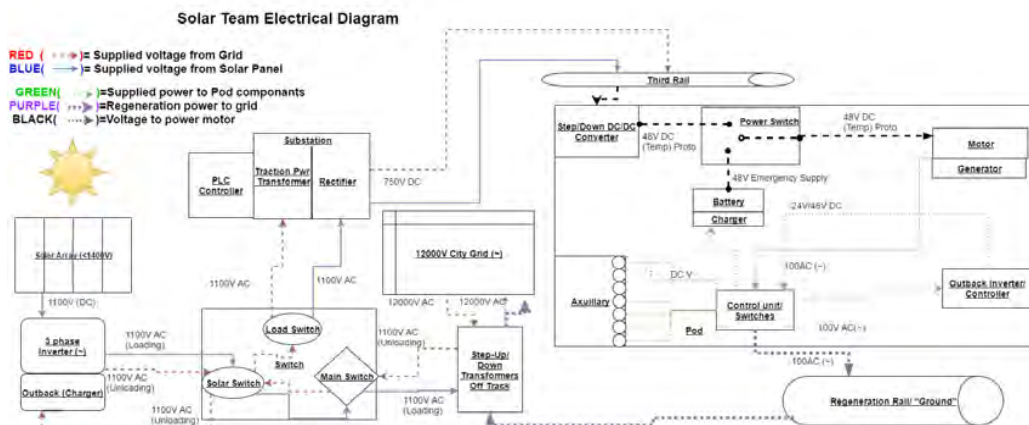

Fig. 11: Solar Team Electrical Diagram

The basic electrical diagram assumes the solar panel array supplies 1100 VDC, and this is inverted (with the same phase as the grid) to 1100 VAC. The 1100 VAC is then gated through a control switch and a series of sub-switches depending on the system component consumption. If vehicles are not consuming all the supplied power, then the 1100 AC voltage will lead to a step-up transformer to charge the city grid system. If significant power is being drawn by the vehicles, then the loading voltage from the solar array is

sunlight hours, the assumed 12 kV AC assumed utility grid will power the system. The 12 kV AC will step-down to 1100 VAC and be synchronized in phase as the inverter using an Outback charger. The 1100 VAC is then switched into a substation the same way it would switch when being loaded by the solar array. In case the solar arrays provide inadequate power, the system will be supplied from the grid as it would during non-sunlight hours.

When the Converter/Substation receives 1100 AC voltage (from the grid or solar array), it outputs 750 VDC directly into the third rail power bus. The third rail is in turn connected to a step-down 48V DC-to-DC converter. The converter will be connected to a control switch which powers the motor. The power control switch will only switch to the battery in the case all power sources shut down. The regenerative braking system (motor-generator) will go into a control unit which will determine where the power is needed. In the case that components on board the vehicle need to be powered, the 100 VAC (assumed) voltage from the motor-generator will go into an inverter and the (assumed) 12-48 VDC will power auxiliary items. Auxiliary items will pull from the onboard battery if the regenerative voltage is not sufficient. If all components are working optimally (battery and auxiliary) then all leftover power will be sent to the regeneration rail "ground". Unlike many three- or four-rail systems, Spartan Superway designed its regeneration rail and ground rail to be the same, thus saving energy. The regeneration would lead into a step-up transformer and charge the grid, thus completing the circuit of our system.

5. Conclusion

In summary, from the results of the power consumption simulation, the main losses of a pod car on Spartan Superway project are mainly related to air resistance, around 53% of the total power consumption, followed by the auxiliary system, which consumes about 31% of overall system energy. This analysis gives an initial prediction of the overall behavior of the ATN implementation on the city of San José. Figure 12 depicts the percentage of all the losses analyzed on this simulation.

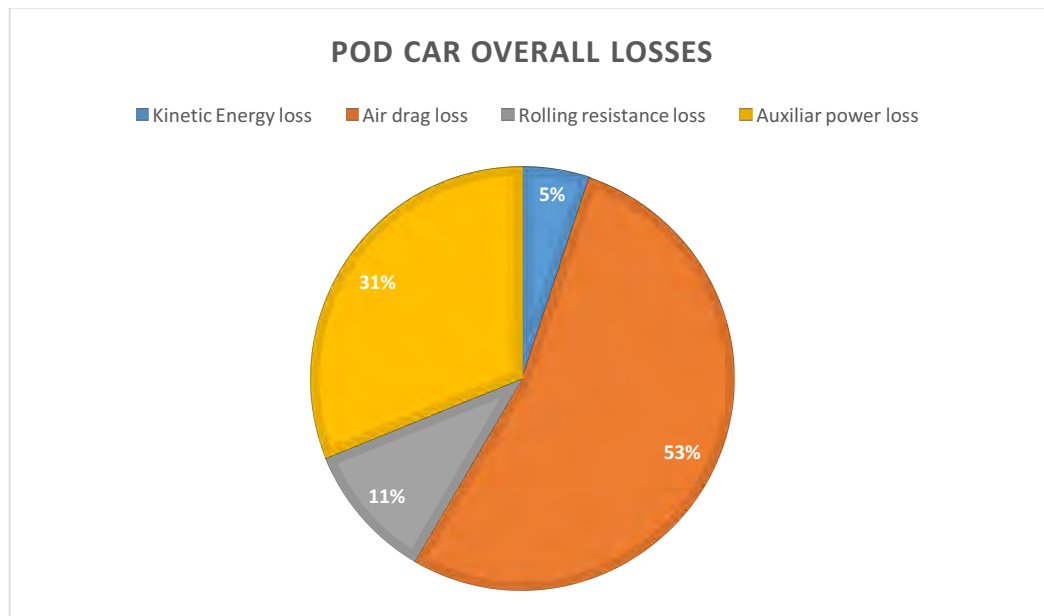

Fig. 12: Pod car overall losses

It is necessary to improve the cabin design to minimize the effects of the air resistance on the pod cars. An optimistic prediction from earlier aerodynamic modeling estimated an air drag coefficient of the vehicle around 0.20 to 0.25, and if this could be achieved, it would represent a 20% gain on the overall performance. From simulations, a proposed 14 km guideway network connecting the north and south campuses of San

José State University requires an installed capacity of 7.0 MW having approximately 19,600 monocrystalline PV panels.

6. Future Work

The power consumption estimation of the ATN can be automated using SAM's Software Development Kit provided by the National Renewable Energy Laboratory. In general, estimates of power required could be improved by refining the assumptions used in the model.

Next steps in research will focus on designing a test track in order to verify possible system failures. The main priorities include designing the guideway layout and selecting the electrical components for the power system. A detailed design of a mounting array for the solar panels accounting for ease of fabrication and ease of assembly is needed, and this should include customizing the electronic and mechanical components, such as the maximizers and mounts. A detailed financial analysis of the test track is also needed.

For the north-south campus network, more work is needed to define actual orientations of PV panels for different sections of the guideway. Other work should include determining the storage system, the size of the battery bank on each section of the track, as well specifying the vehicle batteries.

7. References

- Alvarez, R., et. al., 2016. Spartan Superway: A Solar Powered Automated Public Transportation System. Available at: <http://tinyurl.com/jbla3hz>
- Anderson, J. E. (1988). What determines transit energy use? *Journal of Advanced Transportation ATR*, 22(2), 108-132. doi:10.1002/atr.5670220203
- Cano, J., John, J. J., Tatapudi, S., & Tamizhmani, G. (2014). Effect of tilt angle on soiling of photovoltaic modules. 2014 IEEE 40th Photovoltaic Specialist Conference (PVSC). doi:10.1109/pvsc.2014.6925610
- Lark, R., & Pham, K. D. (2007). Traction Electrification Design for Modern Streetcar Systems. ASME/IEEE 2007 Joint Rail Conference and Internal Combustion Engine Division Spring Technical Conference. doi:10.1115/jrc/ice2007-40040
- Landau, C. (2015). Optimum Tilt of Solar Panels. Retrieved June 24, 2016, from <http://www.solarpaneltilt.com/>
- Paige, T. Automated Transit Network Feasibility Evaluation San José Mineta International Airport San José, CA (2012), San José Department of Transportation
- Ramsey, A. F., & Powner, E. T. (1974). The synchronous moving-cell control philosophy for automated transportation systems. *Transportation Planning and Technology*, 2, 157-164.
- Werts, S., & Hinnov, L. (2011). A Simple Modeling Tool and Exercises for Incoming Solar Radiation Demonstrations. *Journal of Geoscience Education*, 59(4), 219-228. doi:10.5408/1.3651449
- Solar Tracking Solutions for Utility, Research and DIY Solar Power Applications. (n.d.). Retrieved June 24, 2016, from <http://www.heliotrack.com/>
- "Solar Tracking Solutions for Utility, Research and DIY Solar Power Applications." Heliostats and Solar Tracking. N.p., n.d. Web. 29 May 2016.
- System Advisor Model (SAM). (n.d.). Retrieved May 26, 2016, from <https://sam.nrel.gov/>
- Diede, V. (2011, February). The Portland Streetcar Loop. Retrieved July 3, 2016, from <http://www.portlandstreetcar.org/>



ASES National Solar Conference 2016
San Francisco, CA, USA, 10 – 14 July 2016

A study on the effects of urban shadow impingement on solar powered transportation systems

Isaac Gendler¹

¹San Jose State University, San Jose (U.S.A)

1. Abstract

This paper deals with the impinging effects of urban environmental shadows on solar powered transportation systems in order to inform future engineers and city planners on how to construct such infrastructure to take into account the intrusion of shadows onto power generation systems. To study this phenomena, an ongoing solar powered automated transit system project was used as a case study, with a planned route being created within a real time interactive 3D modeling system. Qualitative analysis was performed on portions of the route covering university, residential, and athletic areas, focusing on high-rises, the contrast between single and double storing housing, and an athletic field respectively, all while analyzing the geometry of the shadows at different times of the day. Results were drawn from the study, and improvements were postulated.

Keywords: *Solar power, transportation, shadows, automation, urban*

2. Introduction

As a result of an ever increasing global population, temperature, and congestion, sustainable public transportation options are becoming a greater necessity in the modern age. This paper will describe a solar powered transportation system being developed in the Bay Area called the Spartan Superway. The Spartan Superway is an Automated Transit Network that uses elevated and automated podcars to move around passengers within an urban environment while being primarily powered by solar. However, urban planners and engineers must recognize that there are facets of a highly developed urban environment that can reduce the usable energy of a solar PV system, namely shadows cast by objects such as buildings (Levinson, 2009).

3. Setup

3.1 Description of Case study

The transportation model chosen to study was the ongoing Spartan Superway project at San Jose State University. The Spartan Superway is a personal rapid transportation system designed to run off of renewable resources, specifically solar energy. The Superway works as follows: an elevated guideway encapsulates a city. On this elevated guideway are individual pod cars. Each of these pod cars is completely automated (requiring no driver) and can hold up to four to six people. Passengers can walk up to a station, hail over a ride on their smartphones, and then select their destination. The ride will then continue without any stops. Furthermore, the system is simultaneously powered by a series of solar panels on top of the the track, with a wayside power system to take any

necessary energy from the grid. Since each of the solar panels is in series with one another on a flat plane, the shadows of one solar panel will not affect the power generation of another one . Fig 1. shows a model of the Superway at intersolar 2014.



Figure 1: A real-world model of the Superway was exhibited at Intersolar 2014

3.2 The route

In order to study how shadows can impinge on solar power generation, a route developed by the summer 2016 Spartan Superway Civil Engineering team was chosen for our model. In essence, the route connects the main campus of San Jose State University (located none-other but in the city of San Jose) to the southern athletic center (which will henceforth be referred to as the “south campus”) through a series of residential areas.



(Figure 2) A map of the south campus route, courtesy of the civil team

3.3 Software system

For the purposes of this paper, the south campus route will be analyzed as the case study for shadow effects on solar powered transportation. To perform the analysis, the aforementioned path and a section of Downtown San Jose will be recreated in a three-dimensional modeling software system known as **Encitra** (www.encitra.com). Encitra is a 4D (three spatial dimensions + time) immersive modeling software that allows users to construct almost any object in real time. Most importantly, Encitra generates shadow effects that can be controlled with the time of day. Since the goal of this paper is to construct a general model for the effects of shadow impingement on solar transportation, it was decided to detach the shadow effects from a geographic location to broaden the scope of its applications. A visual example of an Encitra solar network system can be seen in Fig. 3.

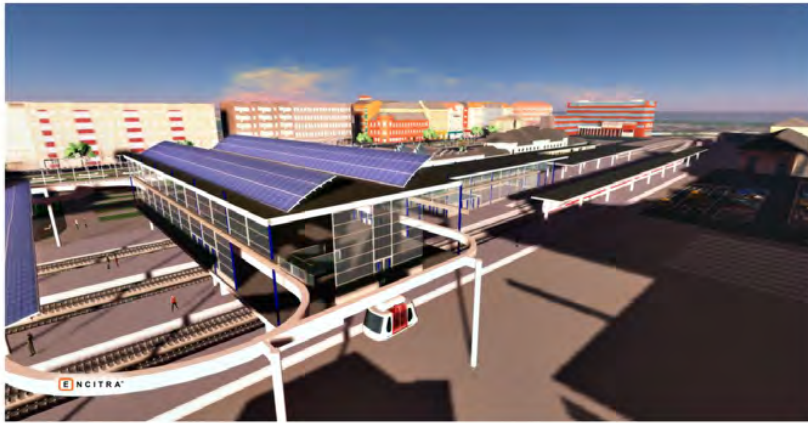

(Fig. 3) An example of the modeling and shadowing capabilities of the *encitra* software

3.4 Modeling

To model the terrain for San Jose, data from the USGS Earth explorer website was downloaded, and with the use of a proprietary process, the terrain map was generated. Once all of the presets were completed, the “south campus” route was modeled in San Jose. The entire trackway was recreated in the software, and (thanks to the generous assistance of the Swedish Encitra team and American Superway modeling team) visualizations of buildings surrounding the guideway were created. a picture of the model can be seen in Fig. 4. Notice how the system blends in nicely with the surrounding environment.



(Fig. 4) The Superway model in Encitra

3.5 Shadow analysis preliminaries

To analyze the shadows, a few procedures were taken. First, the shadows were decoupled from geographic location in order to study a more general solution for global urban environments. To make the analysis process smoother, the morning and afternoon were chosen as the time periods for shadow generation since the peak volume of traffic occurs during these hours (as most commuters are driving to work, and home respectively). Noon was not studied as all of the shadows in the software were directly perpendicular to the ground during that time (proof seen in fig. 5). The Encitra software has been developed to set the default parameters of the shadows based on a latitude of 0 degrees and the time of year to be the solar equinox.

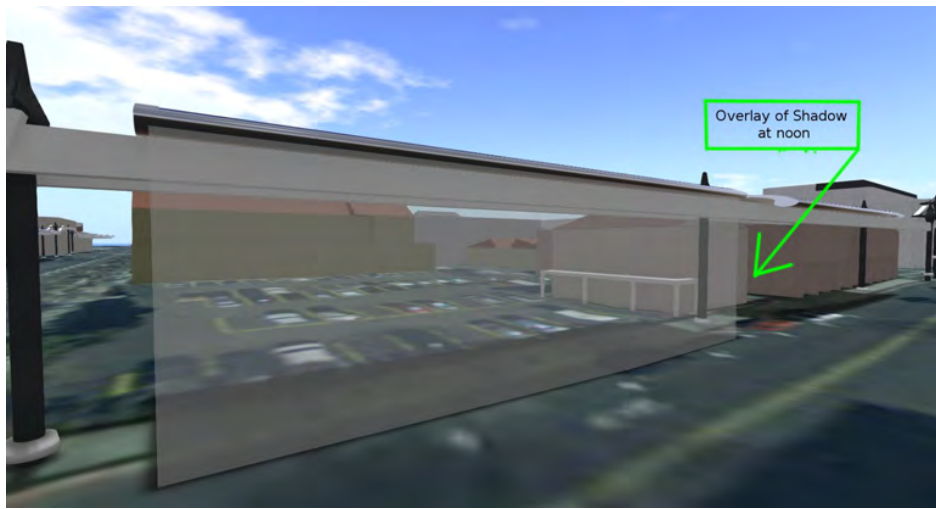

Fig. 5: Shadows at noon, note how the geometry is directly perpendicular to the ground

3.6 Object of study

For our objective, it is necessary to study how shading from an urban environment harms the power generation of solar powered-transport. In order to accomplish this, It was decided to divide the study into three sets; shadows by a university, shadows by a residential area, and shadows by an athletic field. These areas were specifically chosen to focus on high-rises, the contrast between single and double storing housing, and an athletic field respectively Each set was done at 6:00 AM, 3:00 PM, and 6:00 PM. The Teal circle is the University, the dark blue circle is the residential area, and the yellow is the athletic field (fig. 6).



Fig 6: The locations being studied

4. Method

To analyze shadows, the following procedure was developed. First, a high-interest location was scouted. After finding one, the area would be focused in on with a vertical view. Pictures would be taken on the area would then be taken at 6:00 am, 3:00 PM, and 6:00 PM. The shadows were outlined in green, to make them more apparent.

5. Analysis

5.1 The University

For the university area, it was decided to focus in on a high-rise building, as doing so could serve as a future model for similar transportation systems.

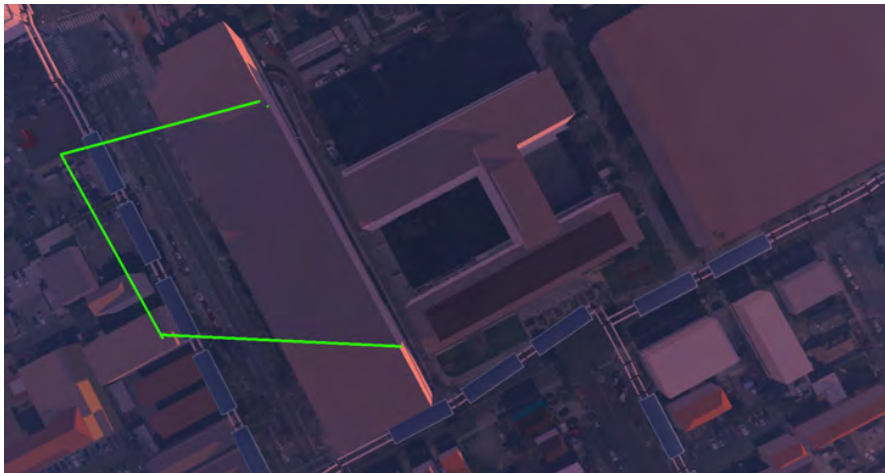

Figure 7: University high-rise at 6:00 AM



Figure 8: University high-rise at 3:00 PM

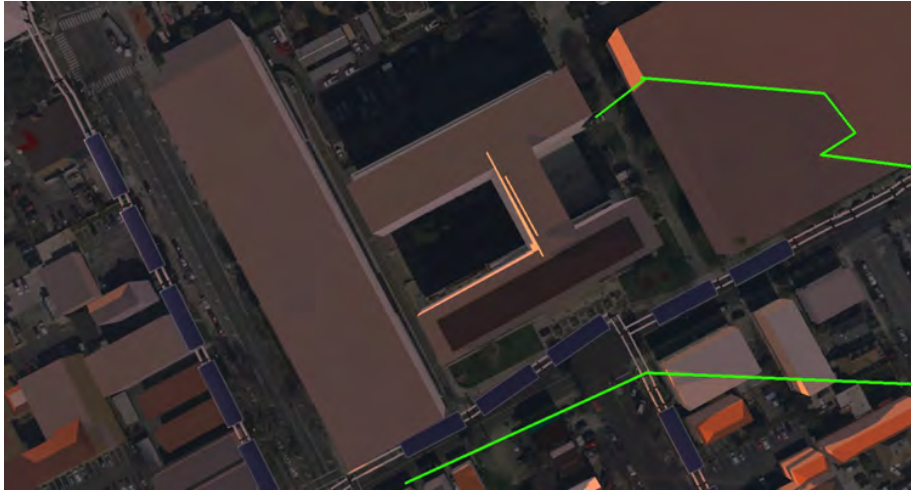

Figure 9: University high-rise at 6:00 PM

As one can extrapolate from Figures 7,8, and 9, the high rise building causes a long-shadow to be cast over the track-way, resulting in major power losses.

5.2 The residential area

The second part to be analyzed by the residential area, precisely the vertical block above the intersection of second street and Pierce avenue. This specific location was chosen since it contains a double-story house flanked by two single story ones, providing a superb model that could simultaneously illustrate the contrasts between mono- and multi-story unit and show how a system could be integrated into a residential area. The double story house is shown in the middle of figures 10.11. And 12 (the dark brown building)



Figure 10: The residential area at 6:00 AM



Figure 11: The residential area at 3:00 PM



Figure 12: The residential area at 6:00 PM

As one can observe in fig. 12, during the late 6:00 PM evening, the shadows from the single story houses miss the guideways, while the double story house envelops the solar panels (even when they are on the other side of the block). Future transportation experts must take this data in to account when planning routes near such areas

5.3 The athletics area

Finally, the “south campus” athletic field was analyzed for shadow impingement. (figs. 13-15)

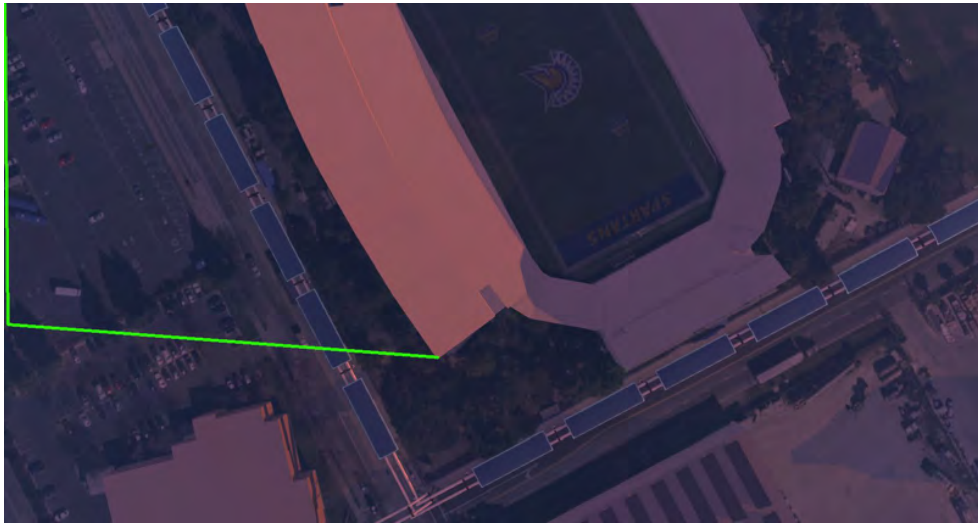

Figure 13: The athletic stadium at 6:00 AM

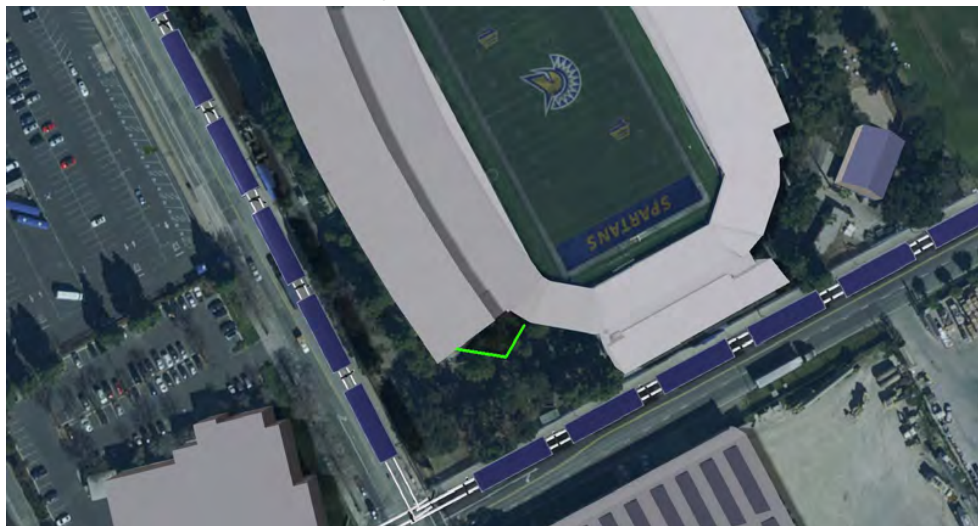

Figure 14: The athletic stadium at 3:00 PM

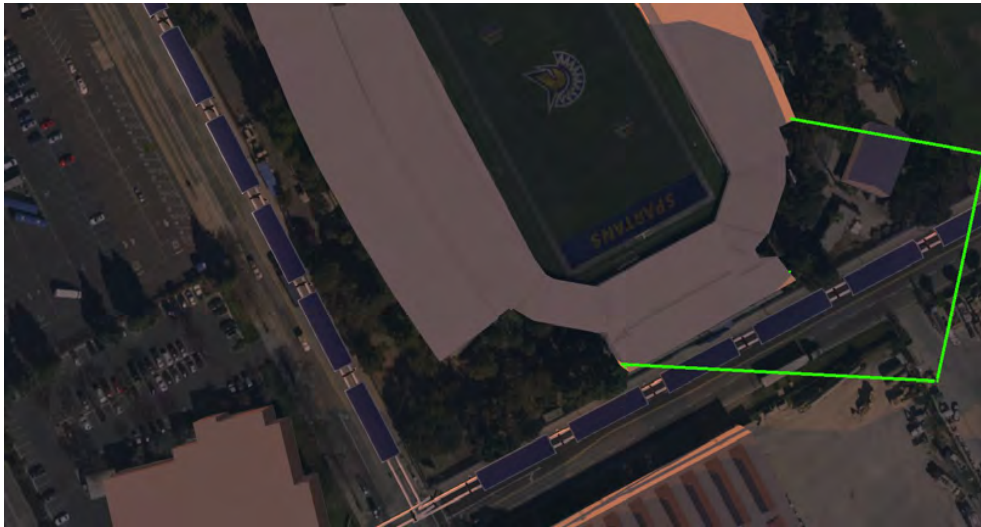

Figure 15: The athletic stadium at 6:00 PM

As one can observe, the athletic stadium creates long shadows that envelops everything in its direction. However, streets near athletic fields are usually surrounded by wide streets, it would be logical if the guideways were put on the opposing sides of the streets, to ensure that the solar panels do not get harmed.

6. Conclusion

After analysis, the following can be concluded. The shadows from single story units are not too damaging, multi-story-units can be incredibly damaging, and putting a solar powered track on the same side of an athletic field would result in a shadow-impinged solar PV-system. Also, at a later stage, this model must be analyzed for pedestrians crossing the street and the effects of foliage.

The results from these studies could be applied to planning future solar powered transportation systems. When taking shadows into construction, it would be rational if solar panels could be mounted at a greater height (so they could dodge shading from two story units), put solar panels on the other side of the street from high rises (to escape the large shadows cast), and install a power storage station (to hold all excess energy from midday, where there is little shading), position the track to be routed to go through single story neighborhoods instead of multi-story areas, connect solar panels onto the roofs of high rises, as such buildings receive large amounts of solar irradiance (Redweik et. al, 2013). In addition, the use of partial shade resistant solar panels could prove to be useful (S. Dongaonkar, & M. A. Alam. (2012)), and omitting solar panels for large stretches of shaded area near skyscrapers would be very pragmatic. Finally, adding solar trackers may not be practical for solar panels in densely urban areas, as such devices would move the solar panels into the direction of the shadows, causing an immediate power loss.

7.. Background literature

References

- Levinson, R., Akbari, H., Pomerantz, M., & Gupta, S. (2009). Solar access of residential rooftops in four California cities. *Solar Energy*, 83(12), 2120-2135. doi:<http://dx.doi.org.libaccess.sjlibrary.org/10.1016/j.solener.2009.07.016>
- Redweik, P., Catita, C., & Brito, M. (2013). Solar energy potential on roofs and facades in an urban landscape. *Solar Energy*, 97, 332-341. doi:<http://dx.doi.org.libaccess.sjlibrary.org/10.1016/j.solener.2013.08.036>

S. Dongaonkar, & M. A. Alam. (2012). A shade tolerant panel design for thin film photovoltaics. Paper presented at the *Photovoltaic Specialists Conference (PVSC), 2012 38th IEEE*, pp. 002416-002420. doi:10.1109/PVSC.2012.6318084

8. Acknowledgements

I would like to save some space at the end of the paper to acknowledge all of the individuals and organizations who have made this paper possible. First and foremost, I would like give my deepest gratitude to Ron Swenson for everything he has done for me, whether it be providing a stipend for living expenses so I can work on this project, providing seminars so I could learn what it means to be an engineer, coaching me on writing this paper, alerting me of the opportunity to publish a paper, and (most importantly) believing in me. You are an amazing individual and I hope that the world will get to know you more. I would also like to thank Professor Furman of San Jose State for introducing me to the Spartan Superway project, helping me navigate my way into the Mechanical Engineering major and for helping kickstart the Spartan Superway project. In addition, Jie Guo should receive much thanks for being my partner in modeling the system and for creating many good houses. I would also like to thank my mother, for forcing me to go to college and raising me during dark times. I would also like to thank my uncle Charles for believing in me, convincing me to travel up north, and for being a good role model. I would also like to thank my high school physics teacher Jed Laderman, for introducing me to the world of science and for teaching me on every topic imaginable. Last but definitely not least, I would like to thank Christer Lindstrom and Caroline Nilsson of 4D-dialog for helping with this project. What all of you have done is quite astounding, and thank you so much for not only jump-starting this project but saving it from the brink of extinction. You will always be in my heart, and it has been the greatest of pleasures working with you.

The Value of Distributed Solar Resources



National Solar Conference 2016
San Francisco, CA, USA July 10-13, 2016

The Right Tone of VOS: Improving the Argument for Local Community Solar

Jill Cliburn¹, Joe Bourg² and John Powers³

¹ Cliburn and Associates, Santa Fe, NM (U.S.A.)

² Millennium Energy, Golden, CO (U.S.A.)

³ Extensible Energy, Lafayette, CA (U.S.A.)

Abstract

This paper describes an alternative to the typical value-of-solar (VOS) analytic approach for supporting utility acquisition of local, distributed solar, relative to centralized solar resources. The specific context is resource acquisition for a community-solar program. The utility in this case could acquire (by ownership or power contract) solar from a centralized solar project for a relatively low cost, or it could include a portfolio of local, commercial-scale solar projects with higher “sticker price,” but strategic benefits. This case sheds light on the utility’s internal-stakeholder debate and on the limitations of detailed bottom-up VOS analysis for some kinds of utility solar decisions. The recommended approach involves building a qualitative, strategic argument, which focuses on relatively few calculated values—three in this case, including strategic-design improvement, reduced transmission costs, and customer-retention value. In other cases, other values or ranges of values might be used. The objective is to apply analytics sparingly, to facilitate better decision-making under highly changeable technology, market, and policy conditions.

Keywords: *Community solar, value of solar, VOS, DER, utility solar, distributed solar, strategic solar*

1. Introduction

The practice of distributed-solar value analysis began in earnest shortly after *Small is Profitable* (Lovins et al. 2002) cataloged 207 possible values of distributed generation. Today, solar-value analyses, commonly called value of solar (VOS) studies, have become ubiquitous in net energy metering (NEM) policy debates. Less often, these analyses have been adapted to utility-planning proceedings and to support new rates or projects. Rocky Mountain Institute tallied 16 major VOS studies in 2013 (Hansen et al. 2013), and since then, many more have been published. The North Carolina Clean Energy Technology Center (2016) notes that policymakers in 28 states were studying the costs and benefits of NEM or the value of distributed generation in early 2016.

Despite their growing role in state policy-making, current VOS methodologies have practical limitations. For example, Cliburn and Bourg (2013) worked with a diverse panel of NEM stakeholders convened by the Solar Electric Power Association (SEPA) to establish a baseline understanding of VOS and NEM-related issues.

Stakeholders from all sides generally agreed upon VOS terminology and even upon most aspects of methodology, but their different perspectives and assumptions led them to very different conclusions. In addition, we found that current VOS approaches often forced an incomplete or static view of the value of distributed solar (DPV), at odds with increasingly dynamic utilities and markets. In its broad study of methods for analyzing solar value, NREL (Denholm et al. 2014) has envisioned developing a comprehensive VOS methodology, while noting that in the meantime, “there are trade-offs between different approaches in terms of accuracy and appropriateness” to the task at hand. We are reminded that, as the saying goes, that the map is not the territory, and analysis does not necessarily equate with understanding.

2. Methodology

The authors’ current work with the Community Solar Value Project (CSVP), funded by the U.S. Department of Energy SunShot program, has suggested the advantages of using VOS analytics sparingly to gain internal utility-stakeholder support for distributed-solar acquisitions. In short, it is the CSVP mission to work with utilities, including a working group that includes Sacramento Municipal Utility District (SMUD), Public Service of New Mexico (PNM), and six other mostly Western utilities, to increase the value of community solar programs. Approaches include strategic siting and design, integration with storage and demand-response, and procurement innovations, regardless of project ownership. Community solar lends itself well to such strategies. Yet, community-solar program design inevitably raises tensions in and among utility departments, where some individuals associate DPV with utility risk and change, and others associate it with risk-management and opportunity.

In working with utilities, the authors have learned that providing a compelling narrative can be more effective—especially early in a program-design process—than providing a full economic analysis. Beginning with a hypothetical case, instead of a specific one, allows individuals within the utility to see past their differences on particular numbers and engage directly in a discussion of strategic possibilities and attainable outcomes. The analytics follow, sometimes as a collaboration involving cross-departmental utility expertise and expertise in solar VOS analytics. In sum, the path for this methodology is marked by four milestones:

1. A sketch of the “realistic hypothetical” solar-program scenario, including relevant problems or challenges;
2. Discussion with utility staff, setting baseline CPV and DPV values (energy, capacity) and identifying a short list of relevant DPV benefit categories, for which net values or ranges of values could be calculated;
3. Selective VOS analysis, to show that the utility could reach the net levelized cost target, which is needed to “close the cost gap” with CPV and justify the DPV investment;
4. Inclusion of additional strategic benefits that could tip the balance if there is still a cost gap between the CPV program resource and a CPV-plus-DPV portfolio option. The overall approach should underscore the changeable nature of technologies, utilities, and markets, and the risk-management value of strategic decisions.

The realistic hypothetical scenario described here involves a generic Northern California municipal utility, which is interested in shared solar, using low-cost centralized solar (CPV) generation, but which also has interest in siting local shared-solar projects. In part, this hypothetical represents a voluntary municipal-utility response to California’s Green Tariff Shared Renewables Program, introduced by SB43. In fact, many utilities in the West have been drawn to CPV resources. These resources can supply solar via familiar utility pathways for prices that Lawrence Berkeley National Laboratory (Bolinger and Seel, 2015) has estimated at \$0.05/kWh. Recent news indicates continued price declines, but this paper uses the \$0.05 benchmark for a Northern California project. While projects approaching 20-MW scale could be sited on the distribution grid, tapping in to the CPV cost advantage, the land requirement for such projects (averaging more than 8 acres per MW) is a limitation for most distribution utilities. Thus, the authors assume CPV is transmission-sited. Community-solar DPV is assumed to be distributed on sites that meet a basic grid-hosting requirement (with higher-value siting requirements to be explored later) and an average 2-MW DPV project scale. Designs include 2 MW of fixed-tilt rooftop solar, 2 MW of single-axis tracking (SAT) solar, and 2 MW of flat-roof carport-integrated solar. The latter two designs are modestly strategic. The average cost for this fleet is

\$0.075/kWh, based on Lazard (2015) and discussions with other consultants working in the region.

Thus, on the face of it, there is a 2.5-cent per kWh cost gap between the all-CPV and all-DPV options. It is understandable that utility resource planners and program designers might be drawn to the all-CPV solution. The case presented here takes a realistic view of the utility's inclination toward cheaper, centralized resources, and it recalls a solution demonstrated in green-power programs (O'Shaughnessy 2015), when utilities sometimes combine lower-cost wind power with a smaller amount of solar PV to reach a combined-price target. Here, we suggest a "fleet" approach, beginning with 20 MW of CPV, plus a total of 6 MW of DPV, as described above. The DPV fleet may grow to include more DPV or to add more innovations, as solar costs decline.

Note that the realistic hypothetical scenario should describe relevant problems or challenges. This scenario will address several, but primarily these two:

- A cost gap favoring centralized solar over DPV, despite a preference among many community-solar participants for DPV. Case studies and market research support this customer preference, but the utility sees the higher cost of DPV as a risk, if customers prove to be more driven by savings.
- A pricing gap between utility-based pricing and rooftop solar competitors. The CSVP (Romano 2016) has documented a utility preference for community solar that avoids virtual retail-NEM pricing, in favor of a cost-based \$/kWh tariff or a charge per "block" of generation. This approach would reward customers for solar generation, while providing greater utility cost-recovery than NEM-based offers. The challenge is for utilities to keep community-solar pricing within range of third-party competitors. Can utilities achieve this without relying exclusively on low-cost CPV?

2.1 Baseline Values and Target Categories for Analysis

A typical VOS analysis quantifies monetary benefits that accrue to the utility through the deployment of DPV systems and/or project strategies. These benefits typically fall within the following general categories:

- Generation Level
- Transmission System Level
- Distribution System Level
- Societal Level

Within these four categories are numerous sub-categories of benefits. Unlike numerous prior studies, our process does not attempt to document all of the potential VOS benefits up and down the chain of monetizable categories. Nor is the purpose to see how high the benefits of DPV can stack. In working with utilities, the authors have recognized that any stacked-benefit graphic would draw utility stakeholders' attention away from the strategic argument, sparking debates over numerous specific values. An alternative approach begins with relatively straightforward agreement on wholesale energy and capacity values. This includes utility-provided hourly avoided energy and capacity costs for the hours of solar generation. Subsequently, we present a simple categorical listing of possible benefits, including measures that address the utility's strategic problems or challenges, and work to select which to explore. Here, we focus primarily on just three strategic values:

- Strategic-design aspects of the DPV fleet
- Avoided transmission costs
- Customer retention value of local vs. centralized community solar

2.2 Analysis of DPV strategic-design benefits

The approach to this analysis will focus on the levelized cost of energy (LCOE) metric, which is commonly used in VOS analyses and throughout the utility industry to make resource planning decisions. LCOE is defined as the costs of a project (fixed and variable) over its expected life divided by its energy production over the same period, on a discounted basis. In simple terms, the LCOE is the net present value (NPV) of the annual costs divided by the NPV of the project's annualized energy production. Note that the authors also

introduce a refinement, specifically identifying a levelized net *benefit* of energy (LBOE) for DPV and incorporating it into the final, fleet net value.

The range of strategic benefits associated with improved DPV project design is great—from the benefits of optimized inverter specification to the benefits of designing for resilience in case of prolonged emergency outages. However, for this hypothetical case, we simply consider how three generic DPV system designs (fixed-tilt rooftop, single-axis tracking and flat-mount carports) impact the need to purchase energy and capacity from wholesale markets or via existing PPAs. Then we derive the benefit of each design, relative to the typical fixed-tilt CPV system. Of course, there was no incremental value associated with the fixed tilt rooftop design, as its design was assumed to be similar to that of the typical CPV system. The flat-mount carport, while generating 12% less energy than a fixed-tilt system on an annual basis, had an incremental avoided cost (0.41-cents/kWh) above the fixed-tilt system. That is because it generates much more power in the summer months, coincident with higher wholesale energy and capacity purchases in Northern California. In fact, this configuration yields 4.2 times the monthly energy production in the peak summer month than in the lowest winter month. Finally, the single-axis tracking system had a higher incremental avoided cost value (1.33-cents/kWh) than the CPV system, since it generates 24% more annual energy on an annual basis than a fixed tilt system of the same size, and its output profile is highly coincident with the highest wholesale hourly power costs.

Combining these strategic-design values in an analysis of the entire 6-MW DPV fleet, the incremental LBOE associated with wholesale power cost savings is 0.64-cents/kWh. In other words, this 6-MW fleet would have avoided wholesale power cost savings that are of 0.64-cents/kWh higher, relative to a typical fixed-tilt CPV project. This savings will contribute to filling the cost gap of 2.5 cents between the CPV-only and DPV-only resource options. Figure 1, below, demonstrates the individual and aggregate generate profiles of the DPV fleet.

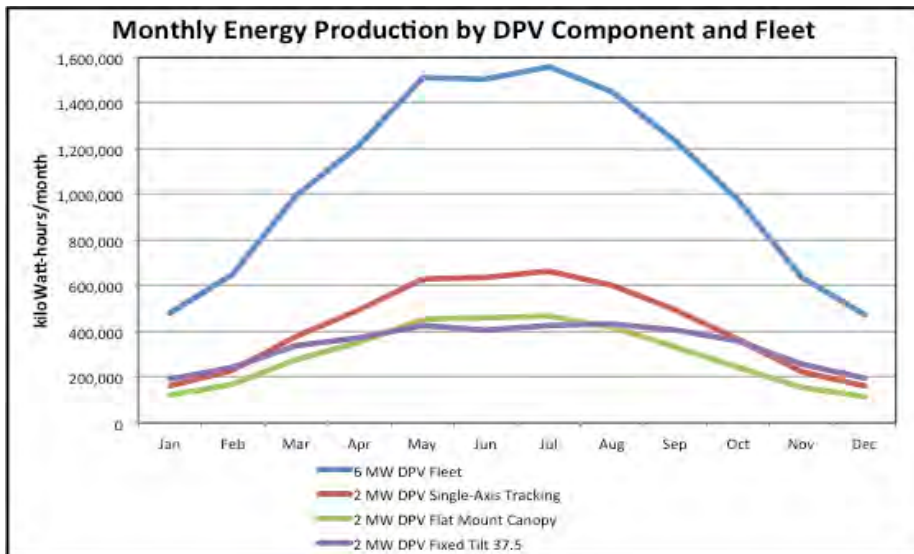

Fig. 1. Monthly energy production by DPV component project-design and by the fleet.

2.3 Analysis of Avoided Transmission Costs

The second category analyzed to fill the cost gap is the incremental value of avoided transmission costs, associated with DPV resources. Avoided transmission cost sub-categories include avoided transmission line losses, avoided ancillary service costs, avoided or deferred transmission capacity investments, and avoided transmission service charges (i.e., firm or non-firm transmission reservation charges). Not all transmission costs are avoided on a 1:1 basis as a result of DPV generation. A robust analytic approach today would require site-specific hourly transmission-cost modeling and additional considerations; in the foreseeable future, researchers at the National Renewable Energy Laboratory and other institutions expect to understand

DER/transmission interactions better and to develop analytic tools to assess DER/transmission values (Palmitier et al. 2016). Yet clearly, significant transmission-related costs would be avoided by DPV, compared to transmission-sited CPV resources.

In order to estimate the potential savings, the authors conducted a literature review. In the literature, transmission-related benefits are treated differently in different studies—often combining transmission system benefits with distribution system benefits as one T&D category, or referring generally to “transmission benefits,” when only one benefit, e.g., the value of capacity deferrals from DPV, is being counted. For example, the U.S. Energy Information Administration (U.S. EIA 2015), suggests transmission cost “based on the average cost to build, operate and maintain these systems using a cost of service regulation model” averaging \$0.0184/kWh (on a levelized basis) for the California market. EIA does not provide detail on its transmission costs, but is assumed to be drawn from the “postage stamp” rate—the flat Transmission Access Charges (TACs) in the California ISO market (CAISO) for delivery of energy from the point of generation to the utility distribution system. One study, completed for the California Energy Commission by the Clean Coalition (Clean Coalition 2015), is more inclusive, and estimates transmission avoided-cost DPV benefits on the CAISO market totaling \$0.03/kWh. The difference between the EIA and Clean Coalition estimates is the escalation rate of future TACs in the CAISO. Both start at the same 2015 TAC value of \$0.018/kWh, but EIA assumes a relatively flat escalation rate in TACs over the next 20-plus years. The Clean Coalition study utilizes the CAISO’s projected average future estimate of 7% nominal escalation (5% real) over the next 20 years, to arrive at its levelized value of \$0.03/kWh. While this value may seem high, a 7% annual escalation rate is less than half of the historical escalation rate (15%) since 2005. It should also be noted that neither the EIA or Clean Coalition studies incorporate the value of line losses in their TAC-based analyses, underscoring that \$0.03/kWh is most likely conservative.

Accepting that arguments for additional avoided-cost benefits can be contentious, the authors note that several other recent sources have found transmission avoided-cost benefits in the same range or higher. For example, the Crossborder study (Beach and McGuire, 2013) submitted to the Arizona Public Service Commission, estimated transmission benefits of DPV in the \$0.021 to \$0.023/kWh range with an additional \$0.015 cents/kWh in savings attributed to ancillary services and capacity-reserve savings, for a total range of \$0.036 to \$0.038/kWh. A recent VOS study in Vermont by the Acadia Center (Acadia 2015) valued the avoided transmission costs for DPV between \$0.027 and \$0.030/kWh on a levelized basis. These studies focus on different regions; they are not perfectly comparable. Yet, such robust DPV benefits strengthen the case for considering some significant range of avoided transmission costs.

This paper’s suggested methodology has an element of negotiation—posing the question, “What is the likely range of values for this benefit?” Rather than assuming there is one true number, we suggest that there is at least one *better* number, which reflects a better understanding of DPV value under likely technical and market conditions. In this case, we assume a LBOE value of \$0.01/kWh for transmission benefits in this analysis—a conservative number from our perspective, but one which can be applied to the DPV portion of this community solar fleet, to help create cost-parity with the all-CPV option.

2.4 Derivation of Revenue-Retention Value

As noted above, this realistic hypothetical case is not intended to be all-inclusive of local solar DPV benefits. The authors are aware of many more benefits that could be added to a considerable stack. However, a first consideration is that, in order to differentiate DPV from this hypothetical utility’s low-cost CPV option, we focus only on values that are *uniquely characteristic of DPV*. Thus, for example, environmental benefits that could be monetized from either a DPV or CPV resource are not considered here. There are other benefits that would likely be on the list—for example, locational distribution-grid benefits that could be introduced if strategic siting were part of the community-solar program design.

However, for this paper, we wish to confront a seldom-recognized benefit, which, if included, would help to create a win-win for the utility and the customer. That is, the need to find acceptable alternatives to retail NEM, as it is commonly used today. The aim would not be to limit customer choice, but to introduce an additional choice, with similar bottom-line pricing, other program-defined benefits, and less erosion of utility wires-charge revenue. Even utilities that accept the value of solar have noted how the very rise of NEM

could create a utility cash crunch, because solar benefits materialize over the long term of the VOS analysis, while funding for grid maintenance and improvements are needed now. This is especially true in today's solar market, where the amount of residential DPV (mostly net metered) has about doubled in two years, 2014-2016 nationwide, bringing California to a total of more than 3,000 MW of DPV by yearend 2015, according to U.S. EIA. Utilities know they are experiencing impacts of a solar market transformation; many now are focusing less on stopping it, and more on a smoother transition, where community solar (possibly including PPA providers and other non-utility partners) could play a role. Utilities are learning that customers might exit any over-priced community-solar program, and turn to a rooftop lease or purchase, while the utility picks up the remaining years on an under-subscribed PPA. Is there a solution that could slow NEM-related revenue loss, while increasing the amount of DPV and improving community-solar pricing?

Our analysis begins with understanding the hypothetical utility's current residential rate tariff. In this scenario, the residential retail rate is \$0.12/kWh. Half of this retail rate represents the value of (standard portfolio) energy, and the other half represents a non-bypassable wires charge. When a customer switches to full-retail NEM for solar on its own property, the associated non-bypassable wires charge (\$0.06/kWh) is entirely lost to the utility. By contrast, a tariff-based community-solar model, similar to one that already exists in California, could include a more strategic, lower non-bypassable wires charge, reflecting the benefit of retaining the community-solar customers who pay it.

In practice, it would be reasonable to negotiate a lower wires-charge burden for all community-solar customers, because the net grid-impact per kWh of generation from a community-solar project is likely to be less than the net grid-impact per kWh of generation from randomly sited and variously oriented rooftop projects. That is part of the often-cited community-solar value proposition. However, for the sake of simplicity, we will examine the \$0.06/kWh non-bypassable charge before any other value-related discounts.

To set the revenue-retention benefit for this hypothetical case, we first need to assess to what extent customers who choose community solar might alternatively opt for NEM rooftop solar. One can assume that customer-rooftop solar, community solar via a CPV tariff, and community solar via local DPV all draw from the pool 50-65% of all electricity customers, identified by a range of studies, who say they are interested in going solar. According to research (Shelton 2016) for SEPA, about 60% of residential customers are interested in solar power, and about 34% of these are seriously considering options. Before receiving any detailed information about options, the breakdown of that 34% includes about 16% who are primarily considering rooftop solar and 14% primarily considering community-solar (4% not reported). Are these groups interchangeable? Another research track in the Shelton work followed the customer decision process and found that indeed, there is movement in customer preference in both directions. For example, Shelton divided a large group of residential customers interested in solar into those initially likely/very likely to choose rooftop and those not likely to choose rooftop. Then each group was presented with information on actual solar options and pricing, for both rooftop and community solar. After two rounds of polling, 45% of the group initially favoring rooftop switched to a preference for community solar, and 35% of those initially disinterested in rooftop switched to the rooftop preference. Pricing was a major factor, but not the only factor in this shift. Reports from existing community-solar programs also suggest the market is somewhat fluid in both directions between rooftop solar and current community-solar options.

If the community solar option were not available or were not competitive, would as many as one-third of customers, who are currently considering solar, choose a rooftop option? We believe the evidence available today is not strong enough to confirm that. But a significant percentage of customers likely would migrate, and at an accelerating rate in places where rooftop solar (with or without NEM) is near retail parity.

The next relevant question is, Does the customer-retention benefit differ for DPV compared to CPV within a community solar program? Anecdotally, the preference for locally-sited projects is strong, but some analysts have cautioned that early-adopters could be a special group. The recent Shelton work addresses this uncertainty, confirming that customers generally prefer local community solar, meaning "solar you can see on a short drive, in your community." This preference is very strong—even at a higher price. But in the context of subscription-based community solar, Shelton links this preference with other aspects of a competitive program offer, including that any premium should be under \$0.03/kWh over the retail rate. If other aspects of the program offer are held constant, there is significant value in keeping community solar local.

In this hypothetical case, the authors recommend incorporating a DPV benefit that reflects the impact specifically of local community solar on customer acquisition and revenue retention. Our methodology would ask the utility to review ranges of likely impacts, settling for this hypothetical on an assumption that *at least* 15% of those interested in solar could go to either community-solar or rooftop options, but would choose community solar, so long as it affordable and includes visible, local projects. Thus, 15% of the of the non-bypassable wires charges in the retail rate can be assigned as a customer-retention value for including a significant DPV in the community solar program. Based on the hypothetical \$0.06/kWh charge, this results in a first-year customer-retention value of 0.9-cents per kWh and an LBOE of 1.17-cents per kWh when levelized over the 30-year term of the solar investment, using a 6.5% discount rate and a 2.5% annual retail rate escalation factor.

The authors concede that this customer-retention analysis is preliminary. In the discussion below, we suggest ways to improve this analysis, including a call for more detailed market research. We assume any offer—rooftop or community solar—could be made more competitive, with resulting impacts on the market. However, in discussing this hypothetical case with utilities (especially in California where solar growth is strong), we found little resistance to the concept that “there is a significant cost to doing nothing.” The recommended process is effective for engaging utilities on their need to offer a better community-solar product at a better price. Incorporating this fairly conservative local-solar benefit on the DPV 6-MW fleet allows the analysis to fill the cost gap between all-CPV and a fleet with significant local solar.

3. Results

A major goal of this paper is to demonstrate that in selecting solar resources for utility-driven community solar, DPV resources can economically compete with CPV projects. This was accomplished through a simplified VOS-type analysis. Calculations were performed to determine the base-case values for CPV and DPV in terms of their gross LCOE, in simple terms, the levelized “sticker price.” Then, a select few high-value incremental benefits of DPV were analyzed to calculate a net LCOE of DPV resources, arriving at a net LCOE for DPV. This net LCOE accounts for a short list of incremental DPV benefits (three in this case) that are not found in CPV. These are expressed in aggregate as the levelized benefit of energy (LBOE) of DPV, as shown in Equation 2. The focus on select benefits that are uniquely characteristic of DPV is a much simpler approach than reviewing all the values of CPV and DPV, and then subtracting the gross benefits of CPV from DPV to calculate the incremental benefits of DPV.

$$LCOE_{DPV\ NET} = LCOE_{DPV\ GROSS} - LBOE_{DPV\ GROSS} \text{ (Eq. 1), where}$$

$$LBOE_{DPV\ GROSS} = 0.64 \text{ cents} + 1.0 \text{ cent} + 1.17 \text{ cents (Eq. 2)}$$

$$LBOE_{DPV\ GROSS} = 2.81\text{-cents/kWh (Eq. 3)}$$

Incorporating those benefits, a side-by-side comparison of LCOE values emerges, as presented below.

Tab. 1. Gross Costs for Centralized and Distributed PV, in Comparison With Net Cost of DPV Incorporating Three DPV-Characteristic Benefits

$LCOE_{GROSS\ CPV}$	$LCOE_{GROSS\ DPV}$	$LCOE_{NET\ DPV}$
\$0.0500/kWh	\$0.0750/kWh	\$0.0469/kWh

The results of these analyses show that the difference in “sticker price” between CPV and DPV dissolves into economic equivalence of these resources. The net LCOE of the value-enhanced hybrid solar fleet is virtually the same as the gross LCOE of the baseline CPV plant. As shown in Table 2, the hypothetical 26 MW fleet, including 20 MW of CPV and 6 MW DPV (rooftop, SAT, and flat-mount carports) has a sticker price that is just over one-half cent more than the CPV alone. Considering available market-research on customer willingness-to-pay for local community solar, one wonders whether to increase the amount of DPV in this fleet, since the cost premium, even before counting DPV benefits, would be quite low. Assuming our hypothetical hybrid fleet, with DPV benefits counted (on a net LCOE basis), there is practically no economic difference between CPV alone and CPV-plus-DPV in a 26-MW fleet.

Tab. 2. Economic Analysis for a Hybrid Community-Solar Fleet

20 MW CPV LCOE _{GROSS}	6 MW DPV LCOE _{GROSS}	26 MW Hybrid Fleet LCOE _{GROSS}	26 MW Hybrid Fleet LCOE _{NET}
\$0.0500/kWh	\$0.0750/kWh	\$0.0556/kWh	\$0.0493/kWh

A second goal for this process was also achieved. These results demonstrate the value of community solar to competitively retain some customers who would otherwise choose to own or lease NEM-based systems. This is shown in reviewing the net LCOE of the community solar fleet versus the LCOE to the utility customer of a NEM system. One California utility consulted for this study indicated that the average offer from third parties to its utility customers for a NEM residential system on a 20-year PPA was \$0.1090/kWh with a 2.9% annual escalation factor. This equates to a customer LCOE of \$0.1323/kWh. With a hybrid fleet average of the net LCOE at just under \$0.05/kWh, the utility has considerable opportunity to recover valid wires charges in community solar pricing, while still offering a competitive product to its customers.

4. Discussion

As noted above, the goal of this methodology is not to build a bottom-up stack of solar benefit values, but rather to work directly with utility staff to build a bridge, to close the perceived cost-gap between CPV and DPV. That goal has been achieved by using only three categories of solar value. The authors could adjust the average LCOE of the fleet either by working with utility stakeholders to count more DPV benefits, or by adjusting the balance between amounts of CPV and DPV in the fleet resource mix. Another option might be for the utility to offer an all-DPV option, keeping the premium within a modest range, as demonstrated by incorporating these three categories of benefits, or by incorporating a subset of other characteristic DPV benefits. One of the main takeaways of this analysis is that utilities have good reason to consider deployment of at least some DPV resources in the community solar resource mix.

In addition to the customer acquisition and retention drivers, there is notable risk-management value in pursuing a diverse resource strategy during these times of change. Risk-management is a key category of strategic value, which our methodology suggests adding to the case narrative, just as prominently as the LCOEs and LBOEs. For example, some utilities are concerned that community solar offers a shorter term for participation and an “easy exit option.” What if the declining cost of solar leads to newer, cheaper third-party offers? A project-fleet solution underscores the risk management value of DPV, as projects can be added incrementally, keeping pace with participation and putting downward pressure on average fleet-based pricing. This strategy leads to other technical and socio-economic benefits, too, of a distributed-fleet approach.

In reviewing the results of this methodology, it is important to underscore the importance of facilitating utilities’ internal-stakeholder processes and building support for local solar, in order to speed much needed clean energy and grid-flexibility advances. The authors have long recognized the inherent conflicts between utilities and stakeholders, especially regarding solar advances (Cliburn and Bourg 2010). The contributions of non-utility innovators in the changing utility landscape are needed, but they will not fully replace utility functions—or certainly not immediately or without utility collaboration. The necessary change in utility mindset from relying on centralized, remote generation resources to working with centralized *plus* local distributed energy resources (DERs) on an increasingly flexible grid is difficult for anyone coming from established utility culture. By using a simplified, solution-oriented approach to VOS, applied to a realistic hypothetical case, utility groups can feel freer to consider new solutions. As noted above, they would not be pressed into agreement on the one *best* number for each incremental DPV value in the stack; they would only work with a short list of values and agree upon one *better* number for each, representing the range of possibilities and dynamics that they must consider. If a short list of agreeable DPV benefits can close a “cost gap,” then implementation of community solar (or other strategic DPV options) can advance quickly, and on a larger cumulative scale.

To be sure, this paper includes preliminary analyses; continued research is needed on several fronts. The

scarcity of market research on community solar and on customer preferences among all kinds of PV needs a lot of work. Nevertheless, the authors present what we know so far, because we hope to prompt a more substantive discussion. A hypothetical municipal utility may have the leeway to employ a customer-retention benefit fairly quickly, but we recognize that other utilities could face tough regulatory scrutiny. At minimum, those utilities that cannot monetize this a customer-retention benefit explicitly may be more open to an equivalent sum of other DPV values to help meet the DPV-benefits target. Further, the authors are currently engaged in developing out a more complete pricing proposal, urging utilities, regulators, and advocates alike to advance strategic, significant, and growing fleets of solar DPV.

5. References

- Acadia Center, 2015. *The Value of Distributed Generation: Solar PV in Vermont*. Boston and New York: Acadia Center. Accessed June 2016. <http://acadiacenter.org/document/value-of-solar-vermont/>.
- Beach, T.R. and McGuire, P.G., May 2013. *The Benefits and Costs of Solar Distributed Generation for Arizona Public Service*. Berkeley: Crossborder Energy.
- Bolinger, M. and Seel, J., September 2015. *Utility-Scale Solar 2014: An Empirical Analysis of Project Cost, Performance and Pricing Trends in the United States*. LBNL-1000917. Berkeley: Lawrence Berkeley National Laboratory.
- Cliburn, J. and Bourg, J., 2013. *Ratemaking, Solar Value, and Solar Net Energy Metering: A Primer*. Washington, D.C.: Solar Electric Power Association.
- Cliburn, J., and Bourg, J., 2010. "A Tiger in the Lifeboat: Making the Most of Utility Solar PV," Proceedings of the American Solar Energy Society, 2010 National Solar Conference, Phoenix, AZ.
- Chung, D., Davidson, C., Ran Fu, Ardani, K., and Margolis, R., September 2015. *U.S. Photovoltaic Prices and Cost Breakdowns: Q1 2015 Benchmarks for Residential, Commercial, and Utility-Scale Systems*. NREL/TP-6A20-64746. Golden: National Renewable Energy Laboratory.
- Denholm, P., Margolis, R., Palmintier, B., Barrows, C., Ibanez, E., Bird, L., and Zuboy, J., September 2014. *Methods for Analyzing the Benefits and Costs of Distributed Photovoltaic Generation to the U.S. Electric Utility System*. NREL/TP6A20-62447. Golden: National Renewable Energy Laboratory.
- Hansen, L., Lacy, V., and Glick, D., 2013. *A Review of Solar PV Cost and Benefit Studies*, 2nd edition. Boulder, CO: Rocky Mountain Institute.
- GTM Research and Solar Energy Industries Association, March 2016. *U.S. Solar Market Insight: 2015 Year in Review*. San Francisco and Washington, D.C.: GreenTech Media and Solar Energy Industries Association. Accessed June 2016. <http://www.greentechmedia.com/research/subscription/u.s.-solar-market-insight>.
- Lazard, November 2015. *Lazard's Levelized Cost of Energy Analysis—Version 9.0*. New York: Lazard. Accessed June 2016. <https://www.lazard.com/perspective/levelized-cost-of-energy-analysis-90/>.
- Lovins, A.B., Datta, E.K., Swisher, J., Lehmann, A., Feiler, T., Rabago, K.R., and Wicker, K., 2002. *Small Is Profitable: The Hidden Economic Benefits of Making Electrical Resources the Right Size*. Snowmass: Rocky Mountain Institute.
- O'Shaughnessy, E., Heeter, J., Chang, L., and Nobler, E., 2015. *Status and Trends in the U.S. Green Power Market (2014 Data)* NREL/TP6A20-65252. Golden, CO: National Renewable Energy Laboratory.
- Palmintier, B., Broderick, R., Mather, B., Coddington, M., Baker, K., Ding, F., Reno, M., Lave, M., and Bharatkumar, A., May 2016. *Emerging Issues and Challenges in Integrating Solar with the Distribution System* NREL/TP-5D00-65331. Golden, CO: National Renewable Energy Laboratory.
- Romano, A., 2016. *Focus on Pricing for Community Solar*. Lafayette: Community Solar Value Project. Accessed June 2016. <http://www.communitysolarvalueproject.com/library.html>.
- Shelton, J. April 2016. "Community Solar: What Do Consumers Want." Presented at the Community Solar Workshop, Denver, CO, April 2016. Research by Shelton Group for the Solar Electric Power Association.

Smart Grid Consumer Collaborative, February 2015. "2015 State of the Consumer." Presented at the 2015 Consumer Symposium, San Diego, CA, February 2015.

U.S. Energy Information Administration (U.S. EIA), 2015. *Annual Energy Outlook 2015* (AEO2015), DOE/EIA-0383(2015). Also accessed, AEO2016. <http://www.eia.gov/forecasts/aeo>.

White, K.S., September 2015. "Clean Coalition Comments on Impact of Transmission Access Charge Allocation on Renewable Energy Transmission Resource Requirements." Presented at the California Energy Commission Renewable Energy Transmission Initiative 2.0 Workshop. For Clean Coalition.

6. Acknowledgements and Disclaimers

This paper include information, data, or work funded in part by the Office of Energy Efficiency and Renewable Energy (EERE), U.S. Department of Energy, an agency of the United States Government, under Award Number DE-EE0006905. All copyright rights are reserved by the Community Solar Value Project (CSVP), and Extensible Energy, LLC, the copyright owner.

This work contains findings that are general in nature. Readers are reminded to perform due diligence in applying these findings to their specific needs, as it is not possible for the authors to have sufficient understanding of any specific situation to ensure applicability of the findings in all cases. Neither the authors nor the CSVP assume liability for how readers may use, interpret, or apply the information, analysis, templates, and guidance herein or with respect to the use of, or damages resulting from the use of, any information, apparatus, method, or process contained herein. In addition, the authors and CSVP make no warranty or representation that the use of these contents does not infringe on privately held rights. Neither the United States Government nor any agency thereof, nor any of their employees, makes any warranty, express or implied, or assumes any legal liability or responsibility for the accuracy, completeness, or usefulness of any information, apparatus, product, or process disclosed, or represents that its use would not infringe privately owned rights. Reference herein to any specific commercial product, process, or service by trade name, trademark, manufacturer, or otherwise does not necessarily constitute or imply its endorsement, recommendation, or favoring by the United States Government or any agency thereof. The views and opinions of authors expressed herein do not necessarily state or reflect those of the United States Government or any agency thereof.

The CSVP acknowledges the contributions of various utilities to this effort. Details and updates are available at the CSVP website, <http://www.communitysolarvalueproject.com>. The authors underscore that the case described is, as intended, a hypothetical, and does not represent specific utility programs or policies.



Influencing Utilities through Shareholder Advocacy: the Madison Gas & Electric Case Study

Don Wichert, Beth Esser

MGE Shareholders for Clean Energy, Madison, WI, USA

Abstract

A group of Madison Gas & Electric (MGE) shareholders came together in the summer and fall of 2014 after being concerned that MGE's proposed 2014 monthly fixed fee increase was leading the company in the wrong direction. The shareholders met as a group a number of times in November of 2014 and decided that submitting resolutions to be included in the annual proxy statement for a vote was the best course of action for MGE management to take notice of shareholders concerns. Two resolutions, for a renewable energy study and executive compensation tied to sustainability metrics were submitted, and later withdrawn in exchange for a written statement, signed by MGE's CEO, to pursue the objectives of the resolutions. A professional renewable energy firm was hired and conducted a renewable energy price study, currently under review. The initial group of 50 shareholders has now become more formalized and is branded as MGE Shareholders for Clean Energy, has developed a logo, and has a Facebook page. In 2015, the group submitted eight new proxy resolutions to MGE management, which prompted MGE to agree to meet with shareholders four times in 2016 to discuss ways MGE could promote clean energy. This paper describes the process and outcomes thus far of the MGE shareholder advocacy.

Keywords: Madison Gas & Electric, MGE, Shareholder Advocacy, Resolutions

1. Introduction

About 50 percent of American households own stock (shares) in various companies and or mutual funds. Each private company with shareholders must comply with regulations enforced by the US Security and Exchange Commission (SEC). This includes the ability of shareholders to propose resolutions to management and other shareholders on how the company should be run. Resolutions promoting policies on clean energy and climate change are becoming more frequent.

1.1. What is Shareholder Advocacy?

Shareholders can use advocacy tactics to promote environmental, social, and governance change from within. The advocacy can take different forms:

- Corporate dialogue: meeting with the company to express viewpoints;
- Resolutions: prescribed directives submitted to the company and included in proxy statements and sent to all shareholders;
- Proxy voting: actual voting on the resolutions by shareholders to "advise" the company on policy direction.

Shareholder resolutions are a powerful way to encourage corporate responsibility and discourage practices that are unsustainable, unethical, or increase exposure to risk. There are several hundred shareholder resolutions filed every year. Resolutions to be voted on are placed on the company's proxy statement, and all persons and institutions that own stock in the company can vote on the issue. The terms *resolution* and *proposal* may be used interchangeably.

The goal of a shareholder resolution is to influence company decision making, thus success is measured by changes in corporate policy and actions. A successful proposal often leads to a dialogue that addresses the concerns raised in the resolution. Many companies seek to avoid a vote, preferring to project a positive image at the annual meeting. If a resolution is voted on, a majority vote is not required for the company to make the requested change. However, these votes are not mandatory, but are only advisory directions to management.

Votes with more than 10% support are difficult for companies to ignore. Resolutions with 20% or more support send a clear message to corporate management that the current company policy is too risky or not beneficial to shareholder interests. Only the least responsive company would ignore one in five of its shareholders.

Resolutions also educate and let other shareholders know about these issues.

According to Proxy Preview (<http://www.proxypreview.org/>): Shareholder advocacy spotlights how corporations affect our planet and everyday lives, and how shareholder resolve can lead to change.

In 2015 there were more resolutions than ever on the environment given a new push for action to battle climate change. In 2015, 415 resolutions were presented to US companies on environmental and social topics, which amounted to 40% of all resolutions filed by shareholders. Of these, 94 resolutions dealt specifically with climate change.

A broad coalition including New York State Common Retirement Fund, the Connecticut Retirement Plans, As You Sow, Arjuna Capital, Calvert Investments, the Unitarian Universalists, and other Interfaith Center for Corporate Responsibility (ICCR) members have come together working under the Investor Network on Climate Risk (INCR) umbrella to focus on climate change financial risk. The shareholder proposals are back-stopped by a Ceres (<http://www.ceres.org/investor-network/resolutions>) coordinated effort supported by 70 investors with \$3 trillion in assets under management. They are asking 45 companies how they will respond to a potential low-carbon future that could strand carbon assets that account for a large part of their market value.

1.2. Filing a resolution

The resolutions are roughly one page (500 words) in length and contain a formal resolved clause, which is a specific request or "ask", with a number of carefully-researched rationales in the form of "whereas clauses" as supporting statements.

Resolutions typically ask corporations to disclose information or to measure and report on the potential impacts of their operations or to adopt or change policies and practices to mitigate against those potential impacts.

SEC rules also specify issues that may not be addressed through proposals. For instance, anything relating to personal grievances or that relates to operations that constitute less than 5% of revenue may be excluded. A company may challenge the proposal at the SEC if it thinks the proposal may be legally omitted. Many challenges relate to rules stating that issues pertaining to "ordinary business" may be excluded. But proponents can challenge the company's logic and if the SEC sides with the shareholder proponents' argument, the proposal must be placed on the company proxy statement and voted on at the annual meeting

Any shareholder with \$2,000 worth of stock held continuously a year before filing a shareholder resolution and who continues to hold the stock through the date of the company's annual meeting is eligible to file. A group of filers can 'aggregate' their shares to meet the \$2,000 minimum requirement. Each shareholder can file resolutions with as many companies as they like; however, they can only file one resolution per company in a year.

2. Engaging Madison Gas & Electric (MGE) Energy, Inc.

Madison Gas & Electric (MGE) is a small investor owned electric and natural gas company serving the very progressive Madison Wisconsin and adjoining Dane County area. In June of 2014, MGE submitted one of the most regressive rate requests of utilities across the country to the Public Service Commission (PSC) of Wisconsin that would have raised the fixed monthly fee for residential electric users from about \$10 a month to \$68 a month. After a massive push back from the local community, they revised their proposed fixed fee increase to \$19 a month. A similar increase also was submitted for the monthly natural gas fixed fee. In the summer of 2014, Beth Esser and Don Wichert met at a RePower Madison (an ad hoc clean energy advocacy group: <http://www.repowermadison.org/>) meeting and discovered they were both MGE shareholders that were disturbed by MGE's corporate behavior. Beth was most interested in the climate impacts on her young children and Don thought MGE should be a national leader in clean energy and not a national leader in regressive policies. They thought other local shareholders may also be upset and decided to organize and explore options to get MGE to change its anti clean energy direction.

RePower Madison led a full blown assault on MGE in the fall of 2014, which included social media, education forums, newspaper ads, letter to the editors, and a picket of MGE's headquarters. This led to over a 1,000 formal negative comments to the PSC opposing the fixed fee increase. A RENEW Wisconsin (a state based renewable energy advocacy group) intern developed a computer code to get the names and contact information

of those filing comments to the PSC and to search for the word “shareholder” in the comments. This resulted in about 50 shareholders being identified that were upset with MGE.

Although MGE had branded itself as a green community energy company, that image did not match the reality. Their fixed rate proposal sends a price signal, which disincentivates energy efficiency and renewable energy and encourages more energy use. In addition, research by RePower Madison had shown that 70 percent of MGE’s energy came from coal contracts that were locked in for 20 to 35 years. MGE had also recently turned down a proposal to partner with the City of Madison on a Department of Energy (DOE) Solar proposal and had no plans to increase its renewable energy portfolio.

Beth and Don thought it was important for shareholders to use their voice to push MGE to change their policies. The changing utility business model, focusing on energy efficiency and distributed renewable, is a way to combat climate change and is needed to succeed over the long term to protect our investment and the future of our children. So, beginning in November of 2014, MGE shareholders came together to attempt to influence MGE executives to be leaders in clean energy rather than the opposite. Currently, in June 2016, there are about 80 shareholders connected via monthly meetings and email communication. Nine shareholders co-filed the two 2014 resolutions and 10 Shareholders are currently in quarterly discussions with MGE executives based on withdrawing the 2015 resolutions.

The following figure shows a timeline for the 2014 resolutions:

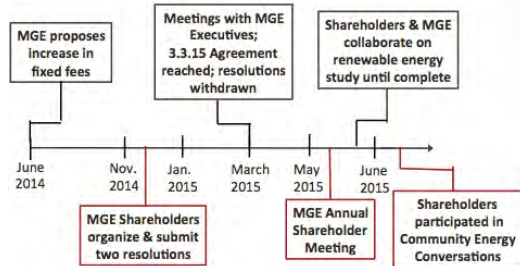

Fig. 1: Timeline for the 2014 resolutions

Shareholders held two meetings in November of 2014 to discuss options to submit resolutions by November 25, the filing deadline to meet SEC rules. The shareholders decided that submitting resolutions to be included in the annual proxy statement for a vote was the best course of action for MGE management to take notice of shareholders concerns. Shareholders initially drafted the six resolutions below:

- 25 % renewable energy by 2025 study;
- Report on potential stranded fossil fuel assets;
- Report disclosing political lobbying over the past 5 years;
- Report on meeting 80% CO2 reduction by 2050;
- Report on how MGE is encouraging distributed renewable energy and how it can be integrated into the grid;
- Tying executive compensation to sustainability metrics.

In the end, two resolutions, a renewable energy study and executive compensation tied to sustainability metrics, were submitted to MGE to be included in the 2015 proxy statement by the deadline.

2.1. Negotiating with MGE and Shareholders

MGE was surprised that shareholders did not let them know of their concerns before resolutions were submitted. MGE did not want their “green” community utility image damaged when 38,000 stockholders and the Madison community would publicly learn about our resolutions through the Proxy statement and subsequent media coverage. The shareholder resolutions were also supported by the City of Madison, which also owned MGE shares. Over the next five and a half months, MGE executives tried to get shareholders to withdraw the resolutions.

Finally, a last minute signed agreement was reached. Shareholders agreed to withdraw the resolutions in exchange for:

- A joint press release by MGE and the shareholders explaining the outcome;
- A written statement in the proxy statement about the resolutions;
- An oral statement at the annual meeting by the CEO on the resolutions;
- An agreement to conduct a renewable energy study with oversight by shareholders;

- A pledge that shareholders would receive private meetings with a professional mediation group, Justice Sustainability Associates (JSA), in a community wide energy engagement process.

Not all shareholders in our group were interested in withdrawing the resolutions. Their argument for not withdrawing the resolutions was that all shareholders would be more aware of MGE’s anti clean energy activities through the vote in the proxy statement. However, in the end, more shareholders thought it better to work “from within the company” and establish a relationship with MGE executives in future decision-making. Most shareholders thought the best way to get MGE to take on a renewable energy study was to agree to withdraw the resolutions in exchange for an agreement that MGE would do a study, and not take a chance that the resolution was defeated in a proxy vote. In addition, if MGE did not do what it promised, more resolutions could be submitted in the next year.

2.2. Impact of the two resolutions and their withdrawal

Shareholders had asked MGE to conduct a cost study of increasing renewable energy sources from the current ~13% to 25% by 2025. In addition, shareholders asked to have executive compensation tied to environmental metrics. MGE managed to side step the executive compensation resolution by arguing that this objective was already occurring and was reported in their biannual “Environmental Report”. Although shareholders did not agree completely, we decided to withdraw the resolution, determined to propose a subsequent resolution in the future with more specific, objective environmental metrics tied to executive compensation.

The renewable energy project, however, actually should achieve more than what shareholders initially had asked for. The group of nine shareholders that formally filed the resolutions began meeting with MGE executives (mostly vice presidents) about the study, which included the concept of 25% renewable energy by 2025 in the resolution. Eventually, shareholders were able to get MGE to issue an RFP for a cost study of increasing MGE’s renewable energy supply to 20% by 2020, 25% by 2025, and 30% by 2030. Shareholders submitted the names of nine firms and organizations (like NREL) that could be qualified to do the study. MGE accepted four of these and added another; so five firms received the RFP and three submitted proposals.

Shareholders were allowed in the selection process and convinced MGE to go with the highest bidder, ICF Inc., who offered the most comprehensive proposal. The study was initially conceived to be finished by the end of December, 2015. However, currently (June 2016) a draft report has just been submitted, a full six months later. Shareholders have yet to see the results, but expect to do so in July 2016.

3.0. The 2015/2016 Shareholder Advocacy

Like many things, shareholder advocacy can continue indefinitely. Pressure is needed to keep the company moving in the right direction. To this end MGE shareholders for Clean Energy have kept meeting every six weeks or so, discussing updates and potential new initiatives, including new resolutions. The following figure describes the time line on shareholder advocacy in 2015 and 2016:

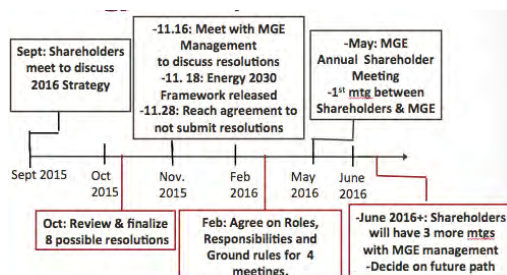

Fig. 2: Timeline for the 2015/16 Shareholder Engagement

After a few meetings in the fall of 2015, the following eight resolutions in four categories were drafted by shareholders in SEC compliant submittal form. Some of these resolutions were repeats from 2014, but most were new.

Policy: “Support federal cap and dividend legislation”

Governance

- “Link executive compensation to carbon reduction”
- “Diversify the Board of Directors with social and environmental experts”
- “Remove the CEO from the Board”

- “Perform a B-Corporation assessment”

Studies: “Perform a risk analysis of MGE’s stranded assets”

Other

- “Perform a study on the economic and social impacts of the fixed charge increase”
- “Report on MGE Foundation giving”

Shareholders decided to meet with MGE executives this year before submitting resolutions. This approach was meant to solidify the relationship with MGE management, to show that shareholders were interested in “working together” with management to study and implement clean energy issues and concerns. About two weeks before resolutions needed to be filed, shareholders and management met and MGE politely listened to shareholder descriptions of the proposed resolutions.

Within the next few days, MGE announced a 15-year clean energy initiative, the “2030 Energy Framework”. The major goals of the framework were:

- 30% retail energy sales by renewable energy by 2030 (with a milestone 25% by 2025)
- Increase EE and conservation (but no specific goal)
- Reduce CO2 emissions 40% from 2005 levels by 2030.

MGE’s marketing spin that described the planning process was: “The company’s vision was informed by input from our nearly 100 Community Energy Conversations; an extensive customer survey; our own industry research, analysis and planning; other collaborative partnerships; and numerous stakeholder discussions.”

On the surface, the 2030 Energy Framework seems like a step in the right direction, and it is. Shareholders felt vindicated that their efforts, in combination with other Madison area clean energy advocates, had made a positive impact on MGE’s decision making. However the four-step community engagement process MGE laid out in cooperation with their facilitator, JSA, was usurped by MGE as indicated by:

- The “Community Energy Conversations” process was not yet complete and no independent report published;
- The renewable energy study is not yet complete. Shareholders had been told: “When the study is done, MGE will combine the study’s results with feedback from the Community Conversations and input from others to develop the path forward”;
- The goals were not as ambitious as other utilities, like MidAmerican Energy, Green Mountain Power, Xcel Energy, Austin Energy, to name a few;
- The goals are not much different from MGE’s previous, business as usual, efforts and may not be enough to mitigate the climate problem. The renewable resource increase is about one (1) % per year, which is similar to MGE’s renewable energy increase over the past 15 years (going from 2% to 13% in 10 years). The 40% reduction from CO2 is already at a 20% reduction from 2005, due primarily to the switch to natural gas at an old coal plant.

3.1. The 2016 Agreement

In the two weeks before resolutions needed to be filed, shareholders reached another agreement with MGE in exchange for not submitting the resolutions. MGE agreed to “provide a forum for holding constructive and collaborative discussions on issues of mutual interest & collaboration to advance their 2030 Energy framework” with up to 10 shareholders. Shareholders agreed to this proposal based on a strategy to engage with executives to push progressive and sustainable policies forward with MGE. Shareholders also wanted to leverage the potential to submit resolutions later in 2016 if shareholder requests were not considered or progress was not being made as fast as possible.

Once again, a formal agreement was signed by both parties, which defined the agreement and its provisions. Over the next three months, a more refined statement was developed, which described the roles and responsibilities of both parties in the 2016 dialogue.

The 10 shareholders met with MGE executives in May 2016 as an introductory meeting and to agree on the process for the 2016 meetings. The first formal meeting occurred in June of 2016 and primarily focused on ways MGE could increase its energy efficiency and community solar efforts. Three more meetings are scheduled to conclude before November 2016, leaving time for shareholders to submit more resolutions by the 2017 Annual meeting resolution filing deadline if MGE does not live up to its part of the agreement.

4. What's next, lessons learned

4.1. What's next?

In the final six months of 2016, shareholders will be involved in:

- Evaluating the ICF Renewable Energy Study with MGE;
- Meeting with MGE on a regular basis to discuss clean energy ideas and policies;
- Connecting with more MGE shareholders;
- Exploring future resolutions;
- Continuing to be a voice for shareholders who support clean energy;
- Encouraging shareholders of other utilities to engage in shareholder advocacy.

4.2. Lessons learned

In the past 20 months, our MGE Shareholders for Clean Energy group has learned quite a bit about influencing our local utility to move toward clean energy polices. Going from no basic knowledge on shareholder advocacy opportunities to being regularly engaged with utility management has been quite an intense, but worthwhile effort. A few key takeaways include:

- Leverage of shareholder resolutions is powerful. Companies do not want all shareholders to hear of their transgressions and will negotiate with shareholders to avoid it;
- Shareholder advocacy is a way to promote environmental, social, & governance change from within. It appears best to develop an ongoing personal dialogue with company executives, if possible.
- Shareholders need to focus on ultimate goals and to keep pushing for tangible results rather than just talk;
- Be prepared for last minute negotiations. Don't back down until you have to;
- A lot of ongoing follow up is needed with companies to complete elements of an agreement. With an all volunteer group, this can lead to mission fatigue. New people need to get energized and be willing to take over the organizations efforts.

5. Summary

Shareholder advocacy is being used across the country as a way for citizens to promote clean energy activities by major corporations, including utilities. MGE shareholders initially formed to fight the 2014 fixed rate increase and MGE's long-term reliance on fossil fuels. This got us in the door and was a way to initially organize. It also started the development of a longer-term relationship with MGE executives.

Our organized shareholder group, MGE Shareholders for Clean Energy, is having a tangible impact on MGE's policies and is now part of the decision matrix that MGE considers when making decisions. Thus far, a major renewable energy price study is under review that considers increasing renewable energy by more than double in the next 15 years. MGE has proposed a citizen engagement process and a major clean energy initiative, in part due to our shareholder impact. Shareholders are also meeting with MGE executives every few months to discuss clean energy proposals that the company should consider.

Corporations do not want negative resolutions in the proxy statement, which can be leveraged by shareholders as one way to get corporations to increase clean energy agendas.

We have accomplished quite a bit, but more needs to be done to get MGE to follow through on their commitments and become a national leader in clean energy. It's an ongoing process, but is worthwhile doing.

6. References

CERES: <http://www.ceres.org/investor-network/resolutions>

Interfaith Center on Corporate Responsibility: <http://www.iccr.org/our-approach/shareholder-engagement-101>

MGE Shareholders for Clean Energy: <http://www.repowermadison.org/mge-shareholder-advocacy/>

MGE-Shareholders for Clean Energy Facebook Page: <https://www.facebook.com/MGE-Shareholders-for-Clean-Energy-450276831815182/>

Proxy Preview: <http://www.proxypreview.org/>



Net Metering PV Distributed Resources Benefits All Stakeholders on PJM

Peter Mark Jansson¹

¹ Electrical and Computer Engineering/Bucknell University, Lewisburg PA (USA)

Abstract

This research documents that all stakeholders (utilities, shareholders, customers – participants and non-participants, society, etc.) benefit from the electric utility policy of net metering of photovoltaics at the distribution level on PJM. It is important to share this objective data given the current political activity across the nation which inaccurately represents that the net-metering policy is somehow harmful to the utility and its customers. The papers finding to the contrary is based upon analysis of real data from locational marginal pricing across the RTO and at specific nodes within it. While one would expect that power generated during the day for a summer peaking utility is of more value to the electric utility system (since demands tend to be relatively higher at that time) this research documents the difference in PV generation LMP to non-generation LMP on a daily, seasonal and annual basis. Further, the value of photovoltaic capacity is not zero since very often PV systems make a significant contribution at the time of the PJM summer utility system peaks. This paper evolves from multiple other research studies which analyzed similar capacity and energy values coincident with PV generation over the past decade but uses the most recent data available which is affected by lower energy and capacity values in general due to the economic downturn. Apart from the obvious benefits that utility customers accrue by being able to use the grid as virtual storage via the net-metering policy this paper looks at the nearest neighbor impact, the distribution feeder impact, capacity planning requirements, the utility system as a whole, the ISO/RTO, as well as all other ratepayers. In all categories net-metering provides positive benefits to all these stakeholders and at present poses no significant burdens or costs onto the utility system or other ratepayers. The research finds that, in fact, PV system owners provide a positive economic value to the grid for which they are presently inadequately compensated. It is clear that electric utility regulators in 42 states, D.C. and multiple territories are aware of this positive benefit accruing to all electric utility stakeholders since they continue to support net metering as an important public policy support for solar technology. This research provides important objective economic assessment data that they can use to defend their current policies.

Keywords: *Net metering, PJM, photovoltaics, electric utility, stakeholders, locational marginal price (LMP), regulators*

1. Introduction

While it is not front page news across the United States it is clearly of great import to the solar photovoltaic community that legislatures and policy makers across the country are reconsidering their regulatory stance of net-metering solar photovoltaic systems as they back-feed local electrical distribution systems. This important public policy has been viewed since its conception as a “win-win” for utilities, their customers and the electricity grid as a system. This paper will develop these benefits more specifically for the nation’s largest interconnection, PJM, the regional transmission organization (RTO) and independent system operator (ISO) serving the northeastern U.S. The recent reversal of this policy in Nevada (Cardwell and Creswell 2016) is alarming to the industry and incomprehensible to policy makers who know the facts regarding the benefits that net-metering accrues to all utility stakeholders.

By 2014 net metering of solar photovoltaic systems in the U.S. was the accepted standard in 43 states (as well as the District of Columbia, Guam, Puerto Rico, American Samoa and the US Virgin Islands) because of the significant distribution and energy benefits it was providing to all consumers of electricity. The status of net metering policies across the U.S. in September of 2014 is shown in Figure 1. Idaho, Texas and Georgia (orange in the figure) allowed each utility to voluntarily set their own net-metering policies, which most did. One can notice from Figure 1 the notation that net metering rules were being actively discussed in over a dozen public utility commissions. By December of the following year (2015) the U.S. Department of Energy’s SunShot program was reporting that over a dozen states were considering net-metering reform. This is illustrated in Figure 2. From all of this “considering” it seems only Nevada took a step in the direction

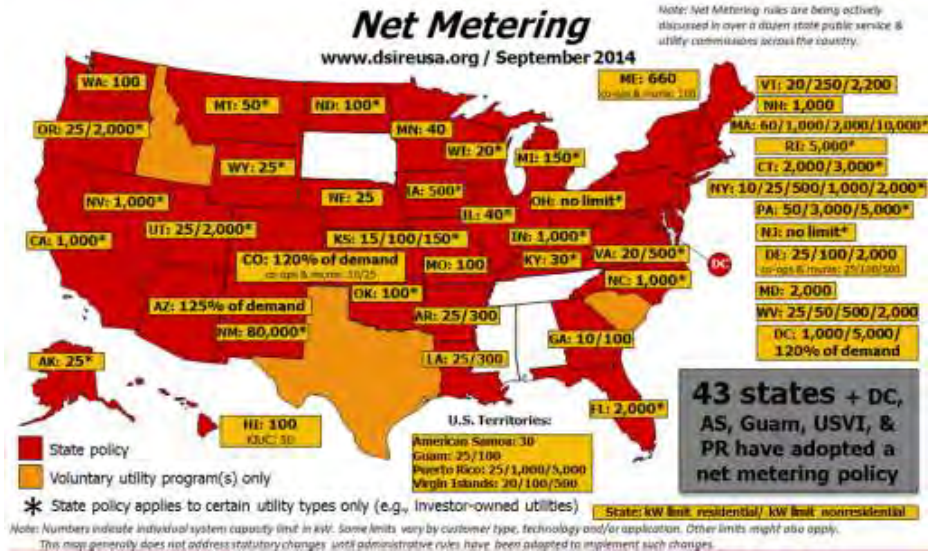

Fig. 1: DSIRE Database of State Net-Metering Policies for Solar PV

Recent Legislative Action for Net-Metering / Rate Design Effecting PV in 2015

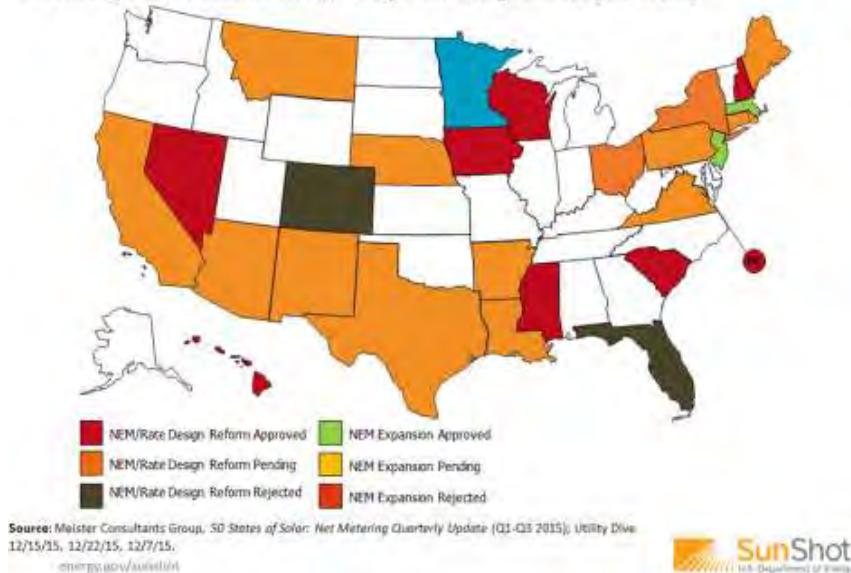

Fig. 2: U.S. Department of Energy SunShot Program – Legislative Action Affecting Solar PV

against the historic support that net-metering had received in 46 (now 45) states. According to the DSIRE website “Senate Bill 374 allowed the Nevada PUC to establish a separate customer class for distributed

generation customers. The post-2015 net metering tariffs reflect this new customer class, with a higher monthly service charge and lower per-kilowatt hour (kWh) energy charge. The bill also gave the PUC broad authority to approve new tariffs that address cost shifts from net metered customers to other ratepayers. Such tariffs may vary from the previous requirements for billing, measurement, and treatment of net excess generation.” (DSIRE, 2016) This bill passed the legislature in 2015 and the public service commission moved rather swiftly to “triple the fixed charges solar customers will pay over the next four years, and reduce the credit solar customers receive for net excess generation by three-quarters” (Pyper, 2016) While an increasing number of net-metering opponents argue on one side of the debate stating that PV customers are subsidized by the grid, the preponderance of evidence even to this date suggests that all customers benefit by PV systems producing electrical power during the high cost, high demand periods of summer peaking utility grids, often allowing the delay of building new peaking generation capacity. This research documents that over the past decade these same financial benefits accrue to all stakeholders of the electric utilities in the PJM region of the U.S.

2. PJM and Locational Marginal Price (LMP)

The PJM interconnection’s load and locational marginal price has been used in this analysis since it is the largest utility interconnection in the continental U.S. It was at one time the largest in the world. It controls the transmission system that serves the loads of over 60 million people and operates in Delaware, Illinois, Indiana, Kentucky, Maryland, Michigan, New Jersey, North Carolina, Ohio, Pennsylvania, Tennessee, Virginia, West Virginia and the District of Columbia. It represents a significant amount of the U.S. GDP within its dispatch regions. Previous objective financial analyses of PJM data (load, capacity and LMP) indicated that on average “the true value of distributed PV generation to the PJM system in recent years is \$77 per MWh.” (Diefenderfer, Prescott, et al, 2015) In essence, the Nevada ruling is saying that customers who generate PV electricity should be penalized financially for doing so, the referenced work says they ought to be compensated since they are in effect providing this distributed generation to their neighbors with no generation or delivery charges (or losses accruing to the distribution company’s infrastructure). Except in an extreme case like the islands of Hawaii, where the grid may not have adequate stiffness to support high levels of DG, all of the continental U.S. has sufficient stiffness and generation assets to support decades of growth. In include two relevant graphics from the Diefenderfer, et al work below that illustrates. The first shows the correlation between PV generation and high utility system locational marginal costs from a PJM utility in 2014 (Figure 3) and the second tabulates data from 2008, 2009 and 2014 showing the magnitude of

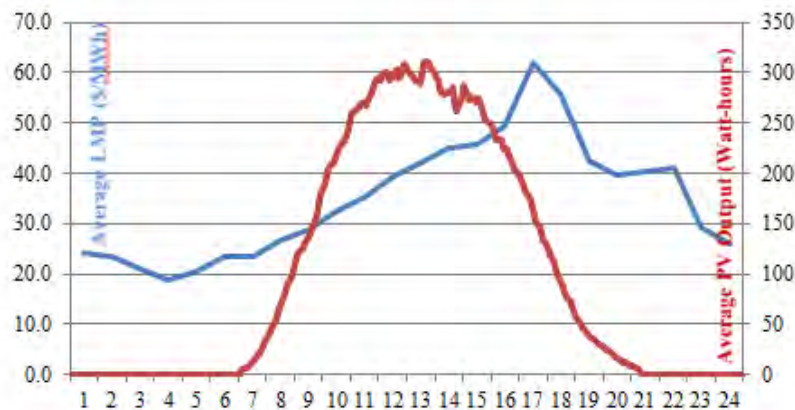

Fig. 3: Average Summer LMP on PJM vs. PV Generation

the differences in LMP between the on-peak solar generation hours and the other non-solar hours for contrast. The data from 2015 presented by this paper shows that the monthly system peak days from June and July 2015 continue to demonstrate that high demand periods and hot, sunny, summer days will always create high costs for all of the utilities (and their consumers) who operate in the U.S.

Tab. 1: PJM and PJM Utilities PV LMP Values (\$/MWH)

	2008	2009	2014	2014 summer	AVE Value
PJM - RTO	22.1	4.6			13.4
PJM - AECO	33.7	8.3			21.0
PJM - PPL			9.0	12.1	10.6

These values clearly indicate that all customers and the utility company themselves experience lowering locational marginal prices as the PV generation is delivered into their distribution feeders. This is not a one year or one day event, this happens consistently on the grid when costs rise as daily demands increase the need to dispatch more costly generators. PJM is the most economically developed grid in the world [PJM, 2016a] providing approximately \$3 billion dollars in value each year to its members and their customers for optimally operating the grid. The correlation between high demand and high system cost is obvious.

3. Coincidence of PV Generation with System Peak Demands

Figures 4 and 5 below demonstrate clearly the direct relationship occurring each summer for demand peaks electric utilities experience. This is no surprise since the peak is caused typically by high cooling demands placed on the grid by air conditioning devices which are driven by the solar gain and high ambient temperatures created on these peak days. Figure 4 is from June 2015, created by one of my students for a laboratory in our power system class (Viglino, 2015) and the other is created directly from the PJM LMP cost and load data freely available for download and analysis by the public. (PJM, 2016b)

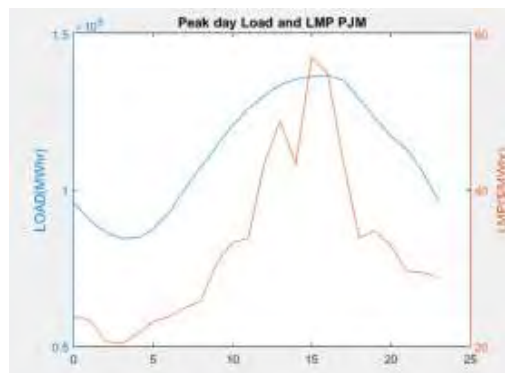

Fig. 4: Student Lab Analysis: PJM LMP vs Peak Day Load - June 2015

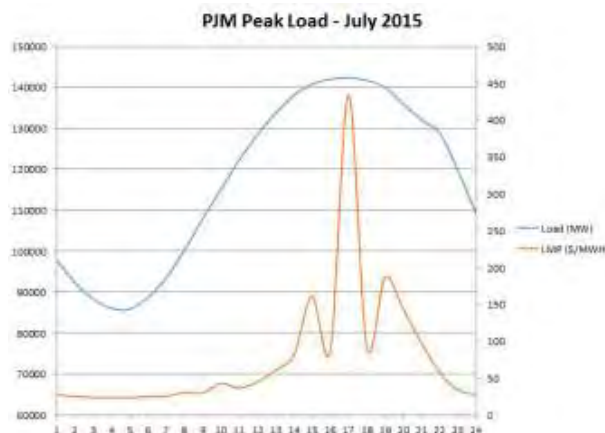

Fig. 5: PJM LMP vs Peak Day Load - July 2015

Over the recent decade (2004-2014) PJM has numerous monthly summer peaks with virtually all of them

occurring before the sun had set and while PV systems were still generating significant electrical power. Table 2 (Diefenderfer, et al, 2015) illustrates that all of the system summer monthly peaks (Jun-Sep) occurred between 4-6pm when during summer the sun was still relatively high in the sky. Historically PJM offered a 38% capacity credit for PV systems to account for their still having a relatively high coincidence with required generation to support the customer peak demand. All of the highest summer peak monthly loads on PJM as provided in Table 3 are illustrated on Figure 6 (Deifenderfer, et al, 2015) where clearly they can be observed as having occurred in daylight hours. An update of the monthly summer peak data for 2015 and 2016 will show this trend is continuing.

Tab. 2: PJM Monthly System Peak Times (2004-2014)

Year	Jan	Feb	Mar	Apr	May	Jun	Jul	Aug	Sep	Oct	Nov	Dec
2014	19:00	8:00	20:00	8:00	17:00	18:00	18:00	17:00	16:00	20:00	19:00	19:00
2013	19:00	19:00	8:00	8:00	17:00	16:00	17:00	18:00	17:00	17:00	8:00	19:00
2012	19:00	8:00	20:00	17:00	17:00	18:00	17:00	17:00	17:00	20:00	19:00	17:00
2011	8:00	8:00	8:00	15:00	17:00	17:00	17:00	16:00	17:00	9:00	19:00	19:00
2010	19:00	19:00	20:00	16:00	17:00	17:00	17:00	17:00	17:00	20:00	19:00	19:00
2009	19:00	8:00	20:00	17:00	17:00	17:00	17:00	17:00	17:00	10:00	19:00	19:00
2008	19:00	8:00	8:00	21:00	17:00	17:00	17:00	17:00	18:00	20:00	19:00	19:00
2007	19:00	20:00	20:00	8:00	17:00	16:00	17:00	16:00	17:00	17:00	19:00	19:00
2006	19:00	20:00	20:00	21:00	17:00	17:00	17:00	17:00	17:00	20:00	19:00	19:00
2005	19:00	8:00	20:00	14:00	17:00	16:00	16:00	17:00	17:00	17:00	19:00	19:00
2004	19:00	8:00	19:00	9:00	17:00	17:00	15:00	17:00	17:00	20:00	19:00	19:00

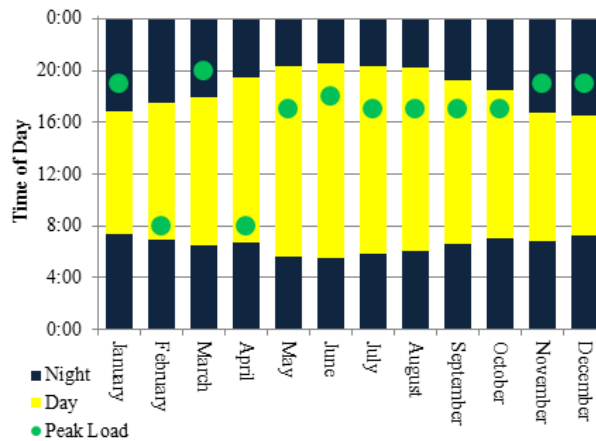

Fig. 6: PJM Peak Monthly Load Times vs. Daylight

When one considers the reduction in peak demand, the lowering of overall locational marginal price for all customers, the value of capacity required to offset the customer peak demand, the losses of the distribution and transmission systems correlating with these high demand periods it is clear that the utility system benefits of PV are significant.

4. Benefits Accrue to All Utility Stakeholders

According to the Energy Information Agency (EIA) around six (6) percent of all electrical energy made in the U.S. is consumed by wire and delivery equipment losses in the transmission and distribution system on an annual basis [EIA, 2015]. These delivery losses are borne by all consumers of electricity (residential, commercial and industrial) by increased electricity rates on average. These real losses are also borne by shareholders if the utility has publicly traded stock, or by the owners of the cooperatives, or by governmental entities depending upon the type of utility. The real system losses increase significantly during the summer for summer peaking utilities due to higher line loading and ambient environmental temperatures which increase further the resistance of the transmission and distribution lines and decay equipment efficiency (transformers being a notable portion). It is well documented that summertime average losses can climb to over 10% with marginal losses reaching 20% when the utility system reaches 100% of its maximum system load [2]. It does

not come as a surprise to most utility policy makers that distributed generation resources with significant summer availability have a beneficial effect on reducing utility system losses. The direct correlation between the peak energy production of PV systems with solar radiation has not gone unnoticed by rational rate-makers and regulatory entities continuing. Since for summer peaking utilities the sun has driven the demand high due to air conditioning loads in residences and businesses being used at maximum to compensate for it, a solar generator will be available during the day to reduce system delivery losses, strengthening the delivery network and providing voltage support and stability all along and at the end of distribution feeders where the utility system needs it the most at such times. In Table 3 a brief summary of dozens of the benefits that distributed photovoltaic systems provide to all major utility stakeholders. It has been provided as illustrative of what is widely known by most regulators, and therefore has led them to conclude that net-metering is not only a sound, well-justified and mutually beneficial public policy for customers and the utility, but is actually the least the grid can do to acknowledge the many uncompensated benefits that distributed generation can provide to better enable the grid operators in meeting their goal of safe, reliable and affordable electric power delivery.

Tab. 3: Benefits of Distributed PV to Stakeholder Groups

Stakeholder	Benefits
Customer – Participating w/ PV	Lower Electricity Bills Lower HVAC Loads – if roof mounted Rapid PV System Payback (ROI) Become More Aware of Electricity Use and Conserve Decreased Carbon Footprint Lower Utility System Costs (LMP, Peak Demand Reduction)
Customer – Non-Participant	Lower System Losses Lower Utility System Costs (LMP, Peak Demand Reduction)
Utility	Lower System Losses – T&D Lower Equipment Losses – Transformers, etc. Better Voltage Stability and Regulation No Generation Needed for PV Power Delivery No Delivery Losses for PV Power Delivery Increased Efficiency of T&D Operation Consumer Load Shifting from On to Off Peak Life Extension of Delivery Assets Capital Deferral for T&D System Expansion/Re-conductoring Capital Deferral for New Generation Increased System & Feeder Load Factors Increased Diversity in Generation Mix Customer Investments Allow Utilities to Meet RPS Requirements
Utility Shareholder	Increased Efficiency of T&D Operation Higher System Profitability Increased System Utilization Customers Share in Capital Generation/Investment
PJM	Higher Overall Transmission System Efficiency Lower Delivery System Losses
Society	Decreased Carbon-Based Electrical Generation Regional and Local Economic Growth (PV jobs, etc.) Cleaner Air Quality & Environment

5. Conclusions

It is clearly an anomaly that the State of Nevada has elected to attempt to reverse the national tide of broad-based regulatory, policy and legislative support for net metering of photovoltaic systems. The specific data described in this paper illustrate that costs are lowered for the system, losses are reduced when the power one consumes has been generated by a neighbor in their local area, everyone benefits from this sound and robust public policy. If we take a look again at Figure 5, last year's PJM average cost data for its July monthly system peak, we can observe that the average system cost (LMP) across the entire RTO exceeded 43 cents per kWh, a typical PV system was probably still back-feeding the grid at that point in time (5 pm) at half of its peak output (see Figure 3). The PV customer who was providing power to his/her neighbors would probably not consume more power until later that night (after 9 or 10pm when their PV system had completely stopped generating). At that point in time when they wanted to buy back the power they had sent to their neighbors at the time of the monthly system peak the PJM LMP had dropped to 5.8-9.8 cents per kWh. The idea that our regulators would feel it is rational and just to penalize such a customer for freely giving their clean, PV generated power to the network in its time of need and taking it back when the prices had plummeted by 80% is unconscionable. The cost to all consumers on PJM for the generation provided for that one hour of the July 2015 peak was nearly \$62M, if consumers had been able to defer their load (like our PV customer did by generating during peak) and consume off peak power at 10pm that night it would have only cost a bit over \$8M. While we are very far away from such a wholesale adoption of PV in the PJM or in the U.S. to experience such a massive load shift and high penetration of PV on the grid, it is excellent that we have the market based model of PJM to rely on for real locational system costs. For the foreseeable future on the continental United States PV producing utility customers should be compensated for the many benefits they provide to the grid for free. At the very least they should be able to continue to feed the grid back at times of high cost (which is true of all PV systems) and then buy it at the same retail credit they sold it at when the system prices have dropped substantially in the off-peak. Penalizing such customers has no basis in rationality when all of these real factors are considered. It is unfortunate that rational, pragmatic and sound public policy has been reversed in Nevada, hopefully the remaining regulators who are considering changes to their net-metering policies will realize that PV customers ought to receive additional compensation for the benefits they provide the grid, benefits that accrue to all stakeholders of the electric power system.

6. References

- Burger, P.D.B., "Electricity production from solar and wind in Germany in 2014," Fraunhofer Institute for Solar Energy Systems ISE, Freiburg, Germany, 2014
- Cardwell, D., and Creswell, J., SolarCity and Other Rooftop Providers Face a Cloudier Future, New York Times – Energy and the Environment, Feb. 10, 2016
- Diefenderfer, P., Prescott, W., and Jansson, P., Energy and Peak Values for Distributed PV in PJM, 4th International Conference on Renewable Energy Research and Applications (ICRERA 2015), Palermo, Italy, 22-25 November 2015, IEEE Xplore DOI: 10.1109/ICRERA.2015.7418611, pp. 1265-1268
- DSIRE, [online available: July 2016] <http://programs.dsireusa.org/system/program/detail/372>
- U.S. Energy Information Administration, "How much electricity is lost in transmission and distribution in the United States?," [Online Available: Jan2015] <http://www.eia.gov/tools/faqs/faq.cfm?id=105&t=3>
- PJM 2016a, PJM Value Proposition [Online available: July 2016] <http://www.pjm.com/about-pjm/value-proposition.aspx>
- PJM 2016b, PJM LMP Data [Online available: July 2016] <http://www.pjm.com/markets-and-operations/energy/real-time/monthlylmp.aspx> PJM System & Utility Load Data [Online available: July 2016] <http://www.pjm.com/markets-and-operations/ops-analysis/historical-load-data.aspx>
- Pyper, J., Does Nevada's Controversial Net Metering Decision Set a Precedent for the Nation? What Nevada's decision could mean for other states, GreenTech Media – Markets & Policy, Feb. 4, 2016 [Online available: July 2016] <http://www.greentechmedia.com/articles/read/nevada-net-metering-decision>
- Viglino, L., Lab #3 PJM, Load Profiles, LDCs and LMP, ECEG 491 Lab Report, ECEG 491, 22 Sep 2015

Poster Presentations



Design of Wearable Agricultural Solar-powered Sprayer for Remote Areas

Abdelnasser M. Farrag
Department of Electrical power and Machines, Faculty of
Engineering, Helwan University, Cairo, Egypt
abdelnasser.farrag@live.com,
abdelnasser.farrag@h-eng.helwan.edu.eg

Abstract

Solar Energy is the present and the future for Egypt. In remote areas, spraying pesticides is done by hand work and fuel sprayers. Solar-Powered Sprayer (SPS) is an innovative product developed for agricultural applications, which utilizes the solar energy as a fuel to be used for spraying the pesticides, Fungicides and Fertilizers. The solar energy is stored in the Lead Acid batter which powers DC pump and LED and the pump is used for extracting the atmospheric air with solute flow to the hose to the nozzle. In the nozzle, both the solute and pressurized air are mixed for spaying. LED Lamp is powered by the stored energy for nightly use for near lighting. The conventional sprayers cost EGP 3,500, but the developed Solar-Powered one costs only EGP 1,100[2]. This Proposed model presents an efficient and economical way of spraying pesticides, Fungicides and Fertilizers and this model .is more reliable and durable for the future

Keywords: *Solar Panel, Battery, Photovoltaic, Agriculture, Pesticide, Spraying*

1. Introduction

Energy is the most essential of all resources. All the energy we use on Earth comes from fission or fusion of atomic nuclei or from energy stored in the Earth. The problem with both fission and fusion is that they have dangerous radioactivity and side effects [3]. Therefore, most of the generation of energy in our modern industrialized society is strongly depending on very limited non-renewable resources, particularly fossil fuels. As the world's energy demand rises and resources become rare, Searching for alternative energy resources has become an important issue for our time. Also rapid growth in energy consumption is the major necessary over the past few years. The energy reserve is limited and is not sufficient to meet the growth in energy demands. Though the fossil fuels are currently available in large quantities, they eventually will finish and on the other hand, the use of fossil fuels leads to environmental worries such as global warming and Climate change. This sounds a serious issue and requires important attention. To deal this issue, renewable energy sources like solar, wind, biomass and fuel cells are the only alternatives remain

Agriculture is very important for the human needs, ensuring food production, and ecosystems, as well as for social and economic development and for sustainable cities. Energy is the most essential of all resources. All the energy we use on Earth comes from fission or fusion of atomic nuclei, or from energy stored in the Earth. The problem with both fission and fusion is that they have dangerous radioactivity and side effects [3]. Therefore, most of the generation of energy in our case industrialized society strongly depends on very limited non-renewable resources, especially fossil fuel. As the world's energy demand rises and resources become rare, the search for alternative energy resources has become an important issue for this century

among the different clean energy technologies, the most effective and peaceful energy source is solar energy. The use of new efficient photovoltaic solar cells (PVSCs) has emerged as an alternative measure of renewable green power, energy conservation and demand-side management. Owing to their high initial cost, PVSCs have not yet been fully an attractive alternative for electricity users who are able to buy cheaper electrical power from the utility grid. However, they can be used extensively for water pumping and air conditioning in remote and rural areas, where [utility power is not available or is too expensive to transport [4 The previous inventions small scale solar sprayers are used on mechanical hand spraying or using the fossil fuels (petro – Gasoline – Kerosene) to spray the solute. The main disadvantage of Mechanical Hand Sprayer is the effort which is used for increase the pressure inside the tank which causes damage in the mechanical hand in the sprayer and the main disadvantage of fossil fuels sprayer is the exhaust gases which affect dangerously the human-being's health, the fossil fuel also adds more weight to it, the exhausting noise and vibration from the fossil fuel engine which harm human's ear, the operating cost and durability. As this solar-powered sprayer is powered by photovoltaic solar cells there is no need for the users to use fossil fuels for spraying or increasing their effort by pushing the mechanical hand. This paper will be the permanent solution for this issue and will be more efficient one.

2. Background and Inventions

Recently, research work was focused on developing the smart agricultural sprayers for small-scale application, which does not have any serious effects on the users. Earliest work from the history clearly says that there has been a remarkable increase in the development for new technique in agricultural sprayer for small-scale application. Initially the powder pest was sprayed by the users with their bare hand. After that, hand sprayer or mechanical sprayer was introduced in early 1960's. In early 1980's Power sprayer came in the market, as an evolutionary version of hand sprayer. Power sprayer is powered by either petrol/kerosene, which drives the DC pump for spraying the solute. For a litre of Petrol 0.78 Acre of land can be covered and in a litre of kerosene 0.50 Acre of land can be covered [5], [8], [18].

In the year of 2010, electric power sprayer introduced. However, from the legacy was mentioned above, can be revealed that none of them is sustainable. In case of hand sprayer, the solute sprayed over the land by the raw hand, pest spraying leads to affect the farmer's health condition. It is worse either by intake of it or by the wounds in their hand. At the same time, hand sprayer farmers should use their fingers in the nozzle to produce the pressure, this leads to create severe hand pain. While considering the power sprayers the weight of the system, operational cost and contamination are major drawbacks. Also the vibration and over weight of the system harm the spinal cord of farmers. To handle those all above mentioned, we designed and implemented agricultural solar-powered sprayer. As it uses the solar power as its main power source, no fossil fuel is needed, no manual pressure is needed and it does not harm users at all. Table 1 shows a comparison of the various types of sprayers.

Table 1. Comparison between the various types of solar sprayers:

	Manual	Fossil Fuel	Solar Power
Pros	No Power Needed	Large Tank	Clean, Sustainable
	Low Cost	Long Continuous	High Pressure
	Common	Spraying	Silent Spraying for Poultry
		High Pressure	Wearable
		Mass Usage	Useful for
			Remote areas
			Nightly-Work
			Zero Operating Cost
			Useful for UPS
			Handy cost
	Low Pressure	Low durability	Absence of Awareness
	Need continuous	Pollution	Wrong treatment and

Cons	pressurizing		Maintenance
	Easy damage in Components	High operating costs	
	Low durability	High cost	
	No Nightly-Work	Need to Fuel Continuously	
	Cannot spray high objects	Large Size and Weight	

3. Characteristics of PV Panel

The solar cell is the basic unit of the photovoltaic panel (PVP). It is the responsible part of transforming the sun photon's energy directly into electrical energy by photovoltaic effect.[10] Nowadays, there are various types of solar cells made with different characteristics are available in the market. These models have varying electrical and physical characteristics depending on the manufacturer. The most commonly used element in the fabrication of solar cell is silicon. [1]

3.1 Solar cell characteristics

The solar cell is simply a diode with large-area forward biased with a photovoltage. The photovoltage is created from the dissociation of electron-hole pairs created by incident photons within the built in field of junction or diode. PV cell is made of semiconducting materials such as silicon that can convert sunlight directly into electrical power and it is usually covered with anti-reflective materials so that it absorbs the maximum amount of light energy. When sunlight strikes the cell, it liberates electrons within the material which then produce DC current. When light becomes incident on a photovoltaic cell without voltage bias (i.e., short-circuit), it creates electron-hole pairs absorbing photons [1] which create a short circuit current (I_{sc}) proportional to the incident light. When both light and voltage bias (i.e., a load connected) are available, the photovoltaic cell current I is the difference between the short circuit current and the dark current I_D . This is shown in the equivalent circuit in Fig.1 where the shunt resistance is usually very high and the series resistance is small.

The operating current of the solar cell is given by

$$I_{diode} = I_0(e^{qV/KT} - 1) \quad [1].$$

$$J_{pv} = J_{sc} - J_{diode} \quad [2].$$

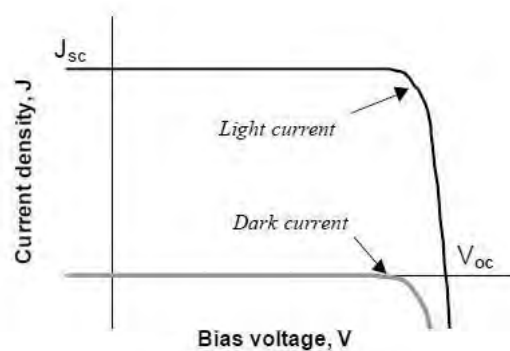

Figure 1. The effect of light on the current-voltage characteristics of a p-n junction

Under darkness, the solar cell is not an active device. It works primarily as a diode. Externally, the solar cell is an energy receiver that does not produce either a current or a voltage. Under this condition: if the solar cell is connected to an external supply, theory shows that the voltage and current are related by the diode equation given by

$$I_d = I_o [e^{(qV/KT)} - 1] \quad [3]$$

$$I_L = I_{sc} - I_o (e^{(qV/KT)} - 1) - I_{sh} \quad [4]$$

Where, I_{sc} is the photocurrent in Amperes, I_L is the output current of solar cell in Amperes I_{sh} is the shunt branch current in Amperes, I_d is the diode current in Amperes, I_o is the saturation current in Amperes q is the electric charge in Coulombs, K is the Boltzmann's constant in Joules/ Kelvin T is the junction temperature in Kelvin.

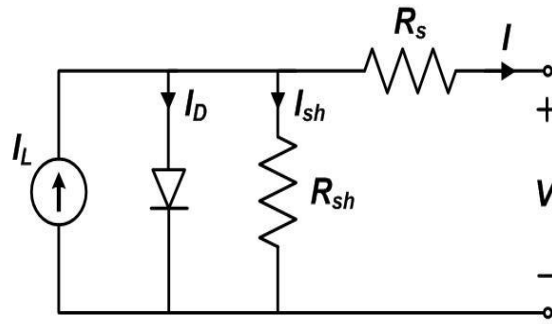

Figure 2. Solar cell circuit model

3.2 Electrical characteristics of Solar cell

The short-circuit current (I_{sh}) occurs on a point of the curve where the voltage is zero, $V = 0$, $I_{sh} = I_L$. Note that I_{sh} is directly proportional to the available sunlight and at this point, the output power of the solar cell is zero. The open circuit voltage (V_{oc}) occurs on a point of the curve where the current is zero. The maximum power output occurs at point ' P_{mpp} ' on the curve shown in Figure 2. The point

' P_{mpp} ' is usually referred to as the "knee" of the I-V curve

$$V_{oc} = \frac{nKT}{q} \ln\left(\frac{I_L}{I_o} + 1\right) \quad [5]$$

$$V_{mp} = V_{oc} - \frac{nKT}{q} \ln\left(\frac{V_{mp}}{\frac{nKT}{q}} + 1\right) \quad V_{mp} = V_{oc} - \frac{nKT}{q} \ln\left(\frac{V_{mp}}{\frac{nKT}{q}} + 1\right) \quad [6]$$

For example, if $n = 1.3$ and $V_{oc} = 600$ mV, as for a typical silicon cell, V_{mp} is about 93 mV smaller than V_{oc} .

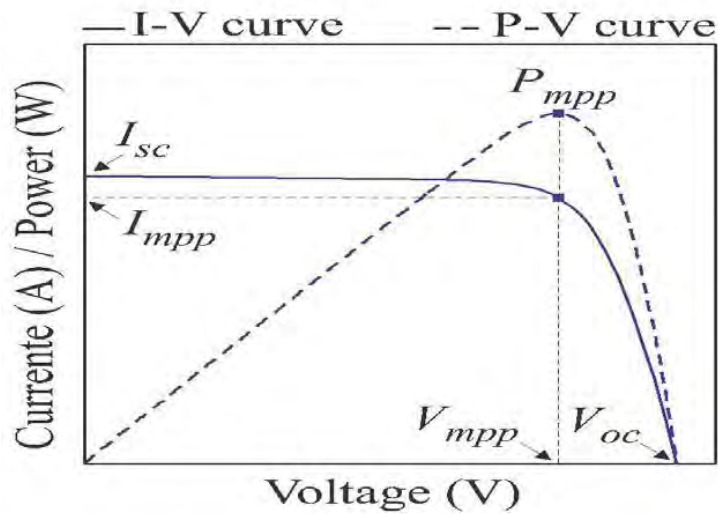

Figure 3. Typical representation of an I-V curve, showing short-circuit current (I^{sc}) and open-circuit voltage (V^{oc}) points, as well as the maximum power point (V^{mpmp} , I^{mpmp}).

The power output at the maximum power point under standard test conditions (STC) (1000W/m²) is known as the ‘peak power’ of the cell. Hence photovoltaic panels are usually rated in terms of their peak watts (Wp).

The *fill factor* (FF), is a measure of the cell quality and series resistance of a cell. It is defined as

$$FF = \frac{V_{mp} I_{mp}}{V_{oc} I_{sc}} \quad [7]$$

$$P_{mp} = V_{oc} I_{sc} FF \quad [8]$$

PV cells are combined to make panel that is covered with glass or clear plastic. Panels can be tied together to make an array that is sized for a specific application. The produced power varies with sun radiation and cells' temperature. If the latter is held constant, this power variation results in a variable current at a fixed voltage. Increasing (decreasing) temperature significantly reduces (increases) PV array's voltage and slightly increases (decreases) current that leads to reduce (increase) the generated power.

The temperature dependency of V_{oc} for silicon is approximated as shown in Figure 4:

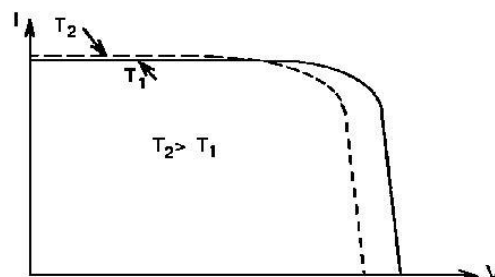

Figure 4. Representation of variance of current and voltage with variance of temperature

This paper is composed of six parts, which include:

- 1) Solar panel is comprised of PV cells. PV cells are made of semiconducting materials that can convert sunlight directly into electricity. When sunlight strikes the cells, it excites and liberates electrons within the material which then move to produce a DC current.
- 2) Solar photovoltaic system are able to produce electricity only when the sunlight is available, therefore stand-alone systems obviously need some type of backup storage which makes them available through the night or bad weather conditions or a certain number of autonomy days for indoors use. Among many backup storage technologies, the lead-acid battery is the most suitable battery for this application because it is relatively inexpensive, produced in high capacity, variable discharging rate and widely available. As well as the control of the operating load voltage is in battery's output voltage's range, so that load receives voltages within its own range of permeability [6], [16], the starting torque in the DC motor is high, but this motor reduces it [5], [7].
- 3) The pump runs directly from the battery with DC current so that the inverter is not needed, the pump is attached to anti-vibration mounting for backbone's safety. This type of design is to allow the sprayer to stand upright on the ground. This pump is able to spray liquid from 0.3 litres to 3 litres per minute with the help of the nozzle. An on/off tap is also attached to the delivery tube. Starting torque is high in Dc motor and this will give a good starting pressure. [12], [18]
- 4) Mini inverter for small home uses, its power is 100w for lighting and small applications. It gives the consumer a small UPS for home's usage in electricity cutout time for remote areas and a solar-powered sprayer in spraying time.
- 5) Charge controller for safety and securing a long life time for the battery, it maintains optimal generated power from sun radiation and differentiate with MPPT technology between current and voltage to achieve the maximum output power, it gives a larger output power for cold climate use.
- 6) Liquid tank is used to store the solute in liquid form. Intake is given from the top of the tank and outlet is taken from bottom of the tank that insures a good pressure for the user.

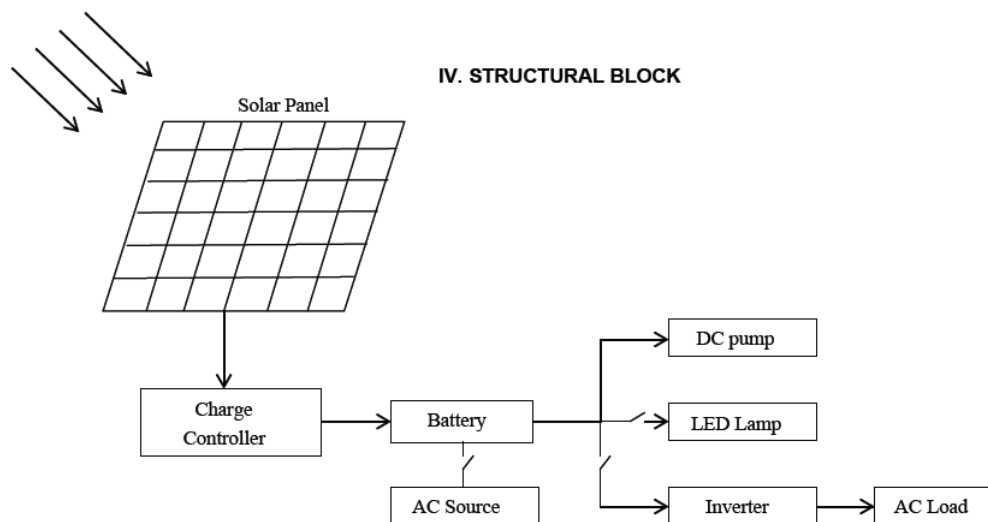

Figure 5: Structural Block of Proposed System

5. Hardware Components

Solar panel is 20W (17.2 Volt, 1.16 Amps). The characteristics of the 20 W solar photovoltaic panel is given in Table 2:

Table 2: Characteristics of the 20 W solar photovoltaic panel

Pmax	20W
Voc	21.6V
Vmp	17.2V
Isc	1.31A
Imp	1.16A
No. of Cells	36
Operating Temperature	40C to 80C-

Charge controller has ratings 5A 12/24V, takes the solar panel's output and regulates it to the battery. The regulated power is stored in the lead-acid battery, which is 12V and 10Ah. It is charged from solar panel at day and charge from AC source with adaptor 12V 1A at night.

Light Emitter Diode (LED) Lamp is 12V, 200mA and 200 Lumens for close lighting. It is connected to the battery and turned on at night by the user.

The inverter is 100W and connected to the battery through on/off switch, it is normally off and when the users is need an electricity backup system for their home, they switch it on.

The liquid tank that contains the solute is 47 cm in length, 35 cm in width, 10 cm in thickness and 16 Litres in volume. It has a belt for wearing on the back. The characteristics of the DC pump is given in Table 3.

Table 2: Characteristics of the DC Pump

Rated Voltage	12V
Rated Current	1A
Pressure	3Bar
Noise	20dB
Operating Temperature	20C to 80C-
Voltage Range	3V to 14

6. Operation of Proposed System

In this proposed system, the sunrays are directly received by the solar panel, which has the ability to convert the light into electric power. The output power of the panel is given to solar charge controller which has maximum power point tracking technique to control the voltage and the current to obtain the battery's charging voltage to prevent the battery from over charging and also increase the battery's life time then, it is sent the lead- acid battery. The battery stores the energy and supplies to the sprayer (for day/night times also). The output of the battery is given to the DC pump, the pump pulls the liquid from the tank and pressurizes it with 3 bar to the nozzle through hose. The designed solar-powered sprayer has the ability to spray the solute up to 4 meters above the ground.

6.1 Features of the proposed model

- The operation and maintenance cost of solar-powered sprayer is negligible compared to the other

models

- Useful for agricultural sector in remote areas and poultry sector without any need of another power source
- Silent Spraying for Poultry
- Environmentally friendly
- Wearable
- Useful uninterrupted power system (UPS)
- Effective and economic use of electricity and water
- Highly reliable
- Durable
- Simple to install

7. Conclusions

This developed model has smaller weight, negligible harm to users and a capability of working day and night times. It can be used as an uninterrupted power system (UPS) during electricity's cutout time and it is charged from AC source at night with adaptor. It is a forward step to endow rural agricultural areas. The main advantage of this developed system is, it does not affect user's health by any ways and also it is friendly to ecological system. By increasing the investments in clean and renewable energy sources, we can build a pure and secure future for the world.

8. References

1. C. Hu and R.M.White, *Solar Cells from Basic to Advanced System* New York: McGraw-Hill,1983
2. Odeh, I., Yohanis, Y.G, and Norton, B, Economic viability of photovoltaic water pumping systems. *Solar energy*, 2006, 80(7), 850-860
3. S. Johnston, P. Gostelow, E. Jones, R. Fourikis, *Engineering & Society: An Australian Perspective*, Harper Educational, Australia, 1995
4. . S.Yuvarajan, Dachuan Yu and Shanguang Xu, "A novel power converter for photovoltaic applications" Elsevier *Journal of Power Sources*, June-2004
5. V. Salas, E. Olfas, A. Barrado and A. Lazaro, "new algorithm applied to maximum power point tracking without batteries" 21 st European photovoltaic solar energy conference, 4-8 September 2006, Dresden, Germany proceeding page no. 2357- 2360
6. B. Lu and M. Shahidehpour, "Short term scheduling of battery in a Grid- connected PVbattery "system", *IEEE Transactions on power system*, Vol. 20, No.2, pp 1053- 1061, May 2005
7. B.L. Theraja and A.K. Theraja, *A text book of Electrical Technology*, volume 2, S. Chand, 2010
8. Agroengine.com. (2016) from [http:// www.agroengine.com/sprayer4.html](http://www.agroengine.com/sprayer4.html). Retrieved 4 March, 2016.
9. http://www.moe.gov.eg/english_new/home.aspx
10. Kassagrocom. (2016). Kassagrocom. Retrieved 4 March, 2016, from http://www.kassagro.com/shoulder_mounted_sprayers.html
11. L.H. Atlas and A.M. Sharaf" A Photovoltaic Array Simulation Model for Matlab-Simulink .GUI Environment, 1-4244-0632-3/07 IEEE
12. Simon S. Ang, *Power-Switching Converters*, Marcel Dekker, Inc., New York, NY, 1995
13. F. Boico, B. Lehman, and K. Shujaee, "Solar battery chargers for NiMH batteries," *IEEE Trans .Power*

Electron., vol. 22, no. 5, pp.1600-1609, Sep. 2007

14. Unsweduau. (2016). Unsweduau, from <http://www.engineering.unsw.edu.au/energy-engineering>. Retrieved March, 2016

15. Sustainable-agricultureorg. (2016). Sustainable-agricultureorg, from [/http://sustainable-agriculture.org](http://sustainable-agriculture.org) Retrieved April, 2016

16. Agroenginecom. (2016), <http://www.agroengine.com/sprayer4.html>, Retrieved 4 March, 2016

17. Waxman, Michael F., (1998) Application Equipment, In: Agrochemical and pesticide safety handbook Ed. M. Wilson. CRC press, Boca Raton (ISBN 9787-1-56670- 296-6) pp.326

18. Kassagrocom. (2016), http://www.kassagro.com/shoulder_mountedsprayers.html, March, 2016.



Challenges for the Expansion of Solar Power in Brazil

Daniela Garcia Giacobbo

Federal Regional Court of the 4th Region – TRF4th Region. Porto Alegre, Brazil.

Abstract

Solar power is still not competitive with other sources in Brazil due to its operating cost and to the lack of investments and tax incentives, even though the country has a high incidence of sunlight. There are also challenges regarding to the regulatory model. In order to expand the electric system and not to be totally dependent on large hydroelectric plants, the Brazilian Government needs to develop a policy diversifying its electric matrix and investing in solar, both on large and small scale, as the distributed generation.

Keywords: *Solar Power, Expansion, Large Scale, Distributed Generation*

1. Introduction

Brazil has a high incidence of daily sunlight for most of the year throughout the country and one of the world's largest reserves of quartz, the raw material of solar panels. However, there are many challenges facing solar energy expansion.

This is because solar is not yet competitive with other sources in the Brazilian electric matrix, predominantly composed of renewable sources. According to the recent Decennial Plan for Energy Expansion (PDE 2014-2024), developed by the

Energy Research Company (EPE), the basis of the Brazilian electric matrix is hydroelectricity, but currently this source has capacity expansion problems.

This hydroelectricity downward trend is reflected in the governmental PDE planning for the next ten years, where hydropower percentage in the electric matrix will drop from the current 67% to 56.7% despite a rise in absolute numbers from 90 GW today to 117 GW in 2024. Of the 73,5 GW planned to be installed between 2014 and 2024, 56.7% will come from hydroelectric power, 11.6% from wind power, 8.7% from biomass, 3.8% from small hydropower plants and solar energy is expected to represent 3.3% of the Brazilian electric matrix. In other words, 84.1% of the expansion should come from renewable sources (Energy Research Company, 2016).

In Brazil, energy is exploited by public concession, in accordance with the provisions of Article 175 of the Federal Constitution (Brazil, 1988). Auctions are determined by order of the Ministry of Mines and Energy (MME) and carried out by the Electric Energy Trade Chamber (CCEE) on behalf of the National Electric Energy Agency (ANEEL). The energy that comes from generation projects and the transmission lines are both contracted through regulated market and free market. This model introduces competitive generation, commercialization of open access and the expansion of the parks is responsibility of bidders. Since the enactment of Law N° 10.848/04, the concessionaires or permit holders of electricity distribution public service are required to purchase by bidding in the regulated market (Brazil, 2004).

The National System Operator (ONS) manages the provision of electricity transmission services, in order to distribute energy between regions, setting the amount that each generation license should produce as well as the amount to be sold by the distribution utilities.

This study will argue that to continue expanding the electric system and not to be dependent on large hydroelectric power plants and extensive transmission lines, the Brazilian government should diversify the



electric matrix, by investing in the non-hydro renewable power generation, especially solar power, both on large scale and distributed generation.

2. The exhaustion of the centralized model based on hydroelectricity

The Brazilian electric sector has experienced previous crisis, because of power generation problems caused by the construction of dams without large reservoirs. In fact, the dependence on the level of the reservoirs is a consequence of federal government policy: in recent decades, the Brazilian government has invested in large enterprises, injecting substantial amounts of energy at once into the system, through hydroelectric plants without reservoir, due to environmental reasons.

However, since the possibilities for construction of new hydroelectric plants with storage capacity and close to consumption centers were exhausted, hydroelectric developments began to be built in the North Region, in the Amazon, where, for topographical and environmental reasons, large reservoirs remained infeasible. Besides this, there are constitutionally protected environmental areas and indigenous territories units in the North Region. Because of these reasons, the construction of large hydroelectric power plants may create legal conflicts, transforming social and environmental issues into one of the biggest risk factors for the implementation of large enterprises.

The reduction of the storage capacity, the increasing power consumption, the hydrologic crisis as well as the fragility of the transmission system are the reasons why centralized generation has reached its limit. Moreover, the difficulty of selling the contracted energy is caused by the delay in issuance environmental licenses. All these issues have

increased the risk of energy deficit, reducing the power supply and overloading the transmission lines.

An audit made by Government Accountability Office (TCU), in 2014, identified major delays in the construction of generation projects and transmission lines auctioned from 2005 to 2012. It was found that 79% of hydroelectric projects had an average delay of eight months, while 83% of the works of transmission lines were also delayed an average of fourteen months. The main causes for the delays were environmental issues. This circumstance led TCU ministers mandated ANEEL and MME to plan bids with consistent deadlines that should guide the planning of future auctions (Brazil, 2014a).

This context will require an effort from the electric planning sector, which is based on rules of the National Energy Policy Council (CNPE), an advisory body of the Ministry of Mines and Energy (MME). The recent Decennial Plan for Energy Expansion (PDE 2014 - 2024) includes the construction of dozens of hydroelectric power plants by inserting about 30,000 MW into the Brazilian park over the ten-year period, but there are only a few references to distributed photovoltaic generation. The study only considered distributed generation as load reduction (Energy Research Company, 2016), maintaining a centralized generation model.

Therefore, to expand the system, which is the largest in Latin America, with an installed capacity of 143 GW, but is also part of a currently recessive economy, the Brazilian Government will need to develop a policy towards the diversification of its electric matrix, stimulating energy efficiency and investing primarily in alternative sources, with the deployment of solar energy.

3. The distributed generation

The PDE 2014 - 2024 incorporated the result of the new energy auctions held up to April 2015. The total potential of the projects that commercialized energy in auctions in 2014 was approximately 7,600 MW, corresponding to an energy power of



approximately 3,900 MW average in the National Interconnected System. This total includes the generation of photovoltaic origin, with a total output of 890 MW. Of this total, 520 MW are located in the Northeast of the country and the rest in the Southeast and Midwest. The heliothermic source is not included in the ten-year planning horizon. However, this source could complement the photovoltaic generation because of its intermittency (Energy Research Company, 2016).

According to ANEEL, among the various processes using solar energy, the most commonly used are water heating and photovoltaic power generation. The first is mostly used in the South and Southeast of Brazil, due to climatic conditions, and the second is used in the North and Northeast regions, in communities not connected to the electricity network.

As for the expansion of solar energy generation in the ten-year horizon, in this plan, the installed capacity in large scale is still unrepresentative, but it already includes R&D projects, power plants installed in the stadiums of the World Cup 2014 and thousands of plants classified as micro and mini generation.

The energy from the solar power plant to be built in Nova Olinda, located in Piauí, was not included in the energy planning but, when completed, it will be the largest in Latin America with 292 MW of installed capacity.

The ANEEL Resolution N° 482, of April 17, 2012, established the regulatory framework for the creation of distributed generation and compensation system, with the discount of 80% (eighty percent) in the usage rates of transmission and distribution for photovoltaic systems that will enter into commercial operation from 2017 (National Agency of Electricity, 2012a). After the enactment of Resolution N° 687, of November 24, 2015, there was a great incentive to the spread of distributed generation, especially the increase in installed capacity of up to 75 kW for micro generation and the expansion of maximum from 1

MW to 5 MW for the category of mini generation (National Agency of Electricity, 2015).

Despite the obstacles, the micro and mini generation advanced significantly in Brazil in 2015. The cumulative number of connections reached 1,731, up 308% compared to the same period in 2014, with only 424 facilities. In the current installed capacity of 16.5 MW, photovoltaics account for over 96% of these facilities, with 1,675 accessions and 13.3 MW, coming even before the wind power plants. The numbers continue to evolve according to this growing trend of distributed generation. In February 2016, the country already had 1,917 facilities, of which 77% were in the residential sector and 14% in the commercial sector, all connected at low voltage (Infopetro, 2016).

The ANEEL Resolution N° 687 introduced new forms of micro generation that allow the development of a number of new business and solar services models such as leasing and Power Purchase Agreement (PPA), acquisition of solar shares, rental roofs and also solar condominiums, among others. ANEEL Resolution created a shared generation, allowing different stakeholders to use a consortium or a cooperative for energy generation, reducing the bills of their members. In addition, the deadline for connecting plants up to 75 kW was reduced from 82 days to 34 days (National Agency of Electricity, 2015).

In this way, there will be a boost to the micro and mini distributed generation in Brazil.

However, the success of distributed generation contrasts with the situation of centralized generation, due to its uncompetitive price.

On October 31, 2014, the source debuted at auctions in the Brazilian market, when around 400 projects were registered, totaling 10,790 MW, a volume almost equivalent to the installed capacity of the hydroelectric plant of Belo Monte. Despite this ambitious debut, due to a restrained demand for many years, only 890 MW of capacity were contracted for the next twenty years, at an average price of BRL 215/MWh (USD 87/MWh). This is one of the lowest prices for solar energy in the world, according to



analyst firm Bloomberg New Energy Finance (BP Group, 2014).

Solar power plants are still not competitive with other energy sources due to the lack of investments and tax incentives.

The concession auctions system, especially after the enactment of Law N° 10.848/2004, which provides as a winner criterion the one who offers the lowest price, has been a factor that discourages the participation and competitiveness in the case of the other renewable energy sources, especially solar energy. This is because investors still do not have the certainty of obtaining credit lines from the official investment bank (Brazil, 2004).

To make solar competitive with other sources there should be demand, official financing and attractive remuneration rates. In the first auction, for example, there was a restrained demand, many projects were registered, but the low price fixed by the government did not attract the bidders, who need to generate revenue and fund the parks.

There is no way to expand or stimulate this source without differential treatment in funding, tax incentives and specific auctions.

4. Regulatory challenges: specific auctions, simplified environmental licensing and tax incentives

Although ANEEL Resolution N° 482 has created the regulatory framework for the sector, there are still legal issues to be faced by investors in solar energy. As part of a policy of incentives for the growth of alternative sources, an auction system for the source with own reference value, set by the grantor in a reserve policy, could be implemented and be used when demanded. This could lead to the provision of electricity service at lower cost, according to the principle of low tariffs, but closer to the reality of the bidders.

As seen above, the bidding for concessions of generation and transmission services comes from constitutional provision and its promotion is delegated to ANEEL, which draws up the notice given to the auction mechanisms defined by order of the MME, which means that an auction for the source could be practiced today in Brazil without regulatory changes.

A simplified environmental licensing for the solar generation projects should be regulated due to their low environmental impact. For this, the government needs to modify the environmental legislation, which is quite rigid in Brazil, considering that the Brazilian electric sector is undergoing a period of deepening discussion on the trade-off between environmental issues and energy security.

In addition to regulatory difficulties, there is the problem of the high price of photovoltaic panels. Tax incentives are essential to develop the sector and the domestic industry. The state investment bank, BNDES, requires many guarantees, such as the progressive nationalization of specific components and processes, and does not fund individuals.

Some initiatives are emerging as the act CONFAZ/ICMS N° 101/1997 (National Council for Financial Policy, 1997), which exempts tax on goods, services modules and solar cells, and more recently, the act CONFAZ/ICMS N° 16/2015 (National Council for Financial Policy, 2015), which focuses on micro and mini generation. There is the Senate bill (PLS N° 8.322/2014) providing for the exemption of the Tax on Industrialized Products (IPI), PIS/PASEP and COFINS for photovoltaic panels and other components made in Brazil and exempts from import tax components that are manufactured in other countries, while there are no national products equivalent to those imported. The text also allows workers to use part of the balance of the Service Time Guarantee Fund (FGTS) for the purchase of photovoltaic systems (Brazil, 2014b). Finally, it is important to highlight that distributors should acquire the energy produced through distributed generation, within the limits of contracting and passing on to



tariffs, according to the Law N° 10.848/2004 (Brazil, 2004). According to Rodolfo Nardez Sirol, in a period of economic recession, "the micro and mini distributed generation is another possibility for industries wishing to reconcile sustainability and cost reduction, producing its own energy from alternative renewable sources." For this author, also promoting actions on energy efficiency can bring a direct benefit to businesses in a short time (Sirol, 2016).

5. Investments in energy efficiency and technology along with smart metering

Moreover, a strategic planning policy is necessary to increase targeted energy efficiency for intelligent consumption in various systems, creating a culture of eliminating waste and optimization of processes, as well as increased competitiveness with cost reduction and with the use of information and telecom technologies.

In this context, the use of Smart Grid system defined as "wide range of mapping technologies, monitoring, information and telecommunications, aimed at a more efficient performance of services" is essential (Mori, 2011).

In fact, the concept of Smart Grid is more than just automation and modernization of the distribution network. The smart metering with the distributed generation could reduce costs and improve the electrical system as a whole. Through the Smart Grid utilities, distributors could make remote operations, control the customer consumption without using manpower to make the measurement, and give more agility in decision making, avoiding also losses in cuts and reconnections. There are also advantages in asset management, because it can monitor the performance of equipment and know when it is overloaded and the time for maintenance. All this is energy efficiency.

However, there are no sufficient studies to know if the devices would increase or reduce the tariffs. This is why the definitive deployment of the Smart Grid in Brazil is still a challenge. But there are important initiatives such as: the creation of a working group to its implementation (Decree N° 440/2010) (Ministry of Mines and Energy, 2010) and the R&D program created by the Brazilian Association of Power Distributors (ABRADEE, 2012) in order to evaluate costs and benefits to the system in the country.

Finally, even with the publication of ANEEL Resolution N° 502/2012, which regulates the deployment of smart meters, there is a lack of standardized equipment in economic scale and adaptable to the world system in order to ensure interoperability between different systems, regardless of the country and the manufacturer (National Agency of Electricity, 2012b). Also, the measuring costs for information technology and telecommunications are high. There is a lack of R&D regarding a smart rate. The share of assets and disposal of low-voltage networks, poles and larger cables are eliminated in the intelligent system, but in Brazil there are no sufficient underground distribution networks. In addition, the deployment of Smart Grid requires the decoupling of rates and sales, the pursuit of efficient and dynamic tariffs design. Mechanisms to protect consumers and energy bills (cyber-security) are needed, using software to increase productivity and reliability of protection systems, given the integration into networks and automated substations.

6. New technologies for the generation: hybrid systems and the floating photovoltaic plants

Some technologies, such as the hybrid parks and the floating photovoltaic plants, are stimulating the development of the source.

The first hybrid wind-solar park began operating in Pernambuco, Northeast, in late September, with an installed capacity of 11 MW of photovoltaic plants and a wind farm of 80 MW. The



hybrid parks allow sharing of infrastructure, such as the connection to the transmission lines, thereby avoiding losses, and promoting a better use of natural resources: during a reduction in the incidence of sunlight, the wind blows more strongly and vice versa. The result is an almost unbroken generation.

Another initiative was the first pilot project in the world of solar energy exploitation in hydroelectric lakes, using floats. It was released on the 4th of March, at the Balbina Dam, in the municipality of Presidente Figueiredo, Amazon. According to the Ministry of Mines and Energy, the initiative has been implemented in other countries, but at common water reservoirs. In Brazil, the floating photovoltaic plant in the Amazon reservoir will generate initially one megawatt (1 MW) of power. It is expected that, in October 2017, the power will be expanded to five megawatts (5 MW), which is enough to supply 9,000 houses. The floats of this first stage were produced in Camaçari, Bahia, and the next will be manufactured in the Amazon. The substation that could be carrying some 250 MW is using only 50 MW. The non-used hydropower 200 MW could be supplemented with solar power plants with a very low cost.

All these initiatives result in energy efficiency and in the possibility to decrease the cost of the electricity tariff.

The floating photovoltaic power plant allows the problem of decreased of hydroelectricity capacity to be solved, due to social-environmental conflicts and the hydrological crisis, as well as the problem regarding to the congestion of transmission lines, using entirely Brazilian technology, creating jobs, besides increasing the utilization of conversion capacity of solar energy.

This engineering design uses the capacity of the reservoirs and the infrastructure of hydroelectric plants, especially those with low power generation capacity. A government research will analyze the

degree of efficiency of interaction with a solar power plant and the influence on the reservoir ecosystem (Ministry of Mines and Energy, 2016).

7. Conclusions

The Brazilian electric sector experienced previous crisis because of the power generation problems caused by the construction of dams without large reservoirs using extensive transmission lines. The social environmental issues and the hydrological crisis are also a constant challenge in the construction of large hydroelectric power plants, which are still the basis of the Brazilian electric matrix. Therefore, to increase its installed capacity and not to be totally dependent on the large hydroelectric plants, Brazil should diversify its matrix, investing in solar power plants.

The sector faces both challenges and opportunities.

Solar power plants can generate local energy, avoiding transmission losses due to long distances, and can provide countless benefits, as it is a clean, renewable and abundant source throughout the country. Amongst other benefits that could be mentioned are: the low environmental impact; the strengthening of national and regional economies with incentives to local manufacturers of solar photovoltaic panels and equipment used in the entire production chain; and the possibility of job creation and economic development, especially in areas with low HDI.

There is no way to expand solar power without specific auctions, funding and tax incentives. It is also necessary to invest in technology, as automated distribution, that, along with distributed generation, will reduce the costs and improve the system. Thus, as demonstrated in the Brazilian government's planning, with the PDE 2014, for the expansion of the Brazilian solar sector there are only economic and strategic planning barriers, not natural ones.

8. References



- BP Group, 2014. Statistical Review of World Energy 2014. Available: <<http://www.bp.com/en/global/corporate/about-bp/energy-economics/statistical-review-of-world-energy.html>>. Accessed: 2016.
- Brazil, 1988. Federal Constitution. Available: <http://www.planalto.gov.br/ccivil_03/constituicao/constituicaocompilado.htm>. Accessed: 2016.
- Brazil, 2004. Enactment of Law N° 10.848/2004. Available: <http://www.planalto.gov.br/ccivil_03/_ato2004-2006/2004/lei/110.848.htm>. Accessed: 2016.
- Brazil, 2014a. Government Accountability Office - Plenary (TCU 029.387/2013-2). 2014. Available: <<https://contas.tcu.gov.br/juris/Web/Juris/ConsultarTextual2/Jurisprudencia.faces>>. Accessed: 2016.
- Brazil, 2014b. Senate bill - PLS N° 8.322/2014. Available: <http://www.camara.gov.br/proposicoesWeb/prop_mostrarintegra?codteor=1419319&filename=Tramitacao-PL+8322/2014>. Accessed: 2016.
- Brazilian Association of Power Distributors (ABRADEE), 2012. R&D Group. Available: <<http://www.abradee.com.br/>>. Accessed: 2016.
- Energy Research Company (EPE), 2016. Decennial Plan of Energy Expansion Report. Available: <<http://epe.gov.br/PDEE/Forms/EPEEstudo.aspx>>. Accessed: 2016.
- Infopetro, blog, 2016. The inexorable advance of distributed microgeneration. Available: <<https://infopetro.wordpress.com/>>. Accessed: 2016.
- Ministry of Mines and Energy (MME), 2010. Decree n° 440. Available: <http://www.normasbrasil.com.br/norma/portaria-440-2010_225253.html>. Accessed: 2016.
- Ministry of Mines and Energy (MME), 2016. Balbina Floating Plant. Available: <http://www.mme.gov.br/web/guest/pagina-inicial/outras-noticias/-/asset_publisher/32hLrOzMKwWb/content/hidretrica-balbina-inicia-projeto-com-flutuadores-para-gerar-energia-solar>. Accessed: 2016.
- Mori, R. L., 2011. The diversification of electricity companies in Brazil: opportunities and entry requirements in the telecommunications sector. Thesis (PhD). Available: <http://www.ie.ufrj.br/images/posgraduacao/ppge/Robson_Luis_Mori.pdf>. Accessed: 2016.
- National Agency of Electricity (ANEEL), 2012a. Resolution n° 482. Available: <<http://www2.aneel.gov.br/cedoc/ren2012482.pdf>>. Accessed: 2016.
- National Agency of Electricity (ANEEL), 2012b. Resolution n° 502. Available: <<http://www.aneel.gov.br/cedoc/ren2012502.pdf>>. Accessed: 2016.
- National Agency of Electricity (ANEEL), 2015. Resolution n° 687. Available: <<http://www2.aneel.gov.br/cedoc/ren2015687.pdf>>. Accessed: 2016.
- National Council for Financial Policy, 1997. Act. CONFAZ/ICMS n° 101. Available: <https://www.confaz.fazenda.gov.br/legislacao/convenios/1997/cv101_97>. Accessed: 2016.
- National Council for Financial Policy, 2015. Act CONFAZ/ICMS n° 16. Available: <https://www.confaz.fazenda.gov.br/legislacao/convenios/2015/cv016_15>. Accessed: 2016.
- Sirol, R. N., 2016. Sustainability in times of crisis, in: Site CanalEnergia. Available: <<http://www.canalenergia.com.br/zpublisher/materias/Newsletter.asp?id=112204>>. Accessed: 2016.



ASES National Solar Conference 2016

Solar Power for Rural America

Julie Glenn

Missouri University of Science and Technology, Rolla Missouri, U.S.A

Abstract

This paper describes the methods for reaching rural citizens of all ages to communicate information regarding solar power and sustainability. In the Ozarks, citizens are genuinely interested in solar power but may not trust the technology initially, perhaps they are cost conscious or perhaps they may not have direct access to reliable, detailed information on the subject. In many cases, these individuals still lack access to the Internet. Big solar providers tend to be located in major cities and it's often troublesome for rural families to travel regularly to these hubs. I explore techniques for reaching this demographic with greater ease. I draw from personal experience and have analyzed approaches from within the small town of Rolla, Missouri. More specifically, I have analyzed the role Missouri University of Science and Technology has played in getting complex topics like solar power to the general populace. Often, the target population are of a lower income tax bracket and big solar companies may discredit the rural population for that reason. Methods for reaching these individuals must be encouraged and well understood. The future is the sun, but we must not forget citizens in hard to reach areas. If one listens to the community, more often than not, they are willing to take the risk of a small array but require a different approach of spreading the word about solar.

Keywords: rural solar, solar, outreach, US Department of Energy Solar Decathlon, energy, sustainability, community, Rolla, Missouri

1. Introduction

The U.S Department of Energy hosts a Solar Decathlon every two years with the help of sponsors. The goal is to inspire clever technology that is eco-friendly, design a home that promotes a sustainable lifestyle and all involving solar power. Universities from around the world design and then build a solar powered home for competition. Students construct the home off site than transport the home to a competition location for about a month. During this time thousands of tours are conducted and different competition contests are conducted to analyze the newest ideas for being more environmentally friendly in an attractive home that's based on Solar Power. Judge walk throughs occur as well as direct measured contests. Richard King the creator of the original solar decathlon spurs great questions that are original to the decathlon but is great inspiration for the challenge. (Sanchez 2016) "How do you design a home that is self-sufficient? A house that is healthy to live in and produces it's own clean power?" This all relates to truly attempting to rebuild twentieth-century infrastructure one house at a time with the focus being solar. Overall Missouri S & T expands on the efforts of the competition including interactive displays, volunteer activities, community outreach and even hands on construction.

Missouri S & T has participated in seven of the eight solar decathlons. It is the 2002, 2005, 2007, 2009, 2013, 2015 and then this includes participation in the upcoming 2017 decathlon. What makes this University unique is the fact that they bring each home back to Rolla to create a Solar Village. This serves as

not only a living lab with different demographics living in the homes at different times but to give daily tours to people from all walks of life. Efforts have even been made to conduct tours in another language including French for example. Families have lived in the homes, single occupants, and even students that include an occasional roommate. The solar village residents try to maintain a sustainable lifestyle at the same time showing tips and suggestions to anyone that passes through regarding life with solar.

Various experiments are always being conducted over a wide range of disciplines and energy usage is monitored on each home. Biology studies have been conducted analyzing the bacteria in the compost bins, and even include analysis on the native plantings within the gardens of the village which is National Wildlife Federation Certified. Economics is also talked about. There is even a 5kw natural gas fuel cell as well as 60 kWh lithium ion battery banks that adds power and storage to the homes. There is an automated intelligent switch gear as well. A micro-grid has been created to connect all the homes together with 21 kw of solar and includes an electric vehicle charging station. The live in laboratories maintain constant feed back with hard data. There is also a great human element of promoting interactions with the public in regards to the panels of monocrystalline, multicrystalline, bifacial, and amorphous. Solar water heating gets described with the solar thermals and the evacuated tubes. An effort to include comprehensive passive solar information is included. The village display is quite a treat because it shows a wide variety of solar applications and a great time frame to illustrate how much the technology truly improves every couple of years with each house.

There are two main elements on the Missouri S & T campus that focuses on Solar. This includes the Office of Sustainable Energy and Environmental Engagement. OSE3 controls the village along with the new Solar Suburb. The suburb is the new location for future homes to be placed as to the fact that the original Solar Village has ran out of room! The OSE3 encourages continued research and promotion that includes many applications for grants. The other element at work to promote solar is the actual Solar House Design Team. The design team has a main focus of building the next competition show piece. The design team is an extracircular activity on campus and OSE3 is an office sector on campus. Both of these groups are heavily involved in public relation tasks and outreach in the community. The Solar House Design Team has even raised money to provide solar self-help books to the local Rolla Public Library.

Methods to reach rural children include tours of a solar display home in Earth Day festivities, Scout outings, participation in the local parades and regular field trips. Tour guides include students that are passionate about sharing tips in eco friendly ideals. The environmentalist mentality of the tour guides and tenants creates the recipe for success that begins to brew in the rural citizens' mindset. Children that are unable to come can still have fun learning about solar power because events are held fairly often throughout town. Some event examples are that university students create children's books that deal with solar power and sustainability topics. This specific activity will have two functions. University students are forced to think of complex topics and find ways to break that down to simpler terms. This will enable them to talk and teach solar at later times because they had to be able to write stories for children creating examples, and of course including fun pictures for a range of younger children. Then have those children critique books and explain their own thoughts on how to improve the book. The reviewed books eventually aid the university student with revisions and to flush out ideas. Giving the younger children a mission to make a better story so it can be shared later on with others inspires deep thought and dialogue about solar as well.

A method to tie in nursing homes tenants as well as senior citizens in general is key to a successfully integrated community that promotes solar. An effort to include older citizens by having them receive crafts from the young ones have been made. Children make door decorations along side solar house team members. These are crafts and drawings that include everything in relation to the sun. Solar House team members can aid in thinking up inspirational sun related quotes and this promotes bonding in the community.

To reach adults in a rural setting one must have a platform to host question answer periods. Interactive tours are great for this but so is hosting an eco-home show, and lectures at libraries and various venues, Rotary Clubs and info-stations set up at a hardware stores. Fundraisers for various causes centered in the village are often times a big draw as well. The various fundraising events often times are 5 k run events, dance a thons, cooking sessions, and crafting moments. Holiday themed activities range from haunted house tours in October, and community gift wrapping. Setting up an informational tents at the local farmers market really can bring in a crowd as well. Efforts to discuss the solar powered homes on the local radio stations have been made, blog articles written and newspaper stories have been typed up all in an effort to get the word out about solar or even just the announcements of when events will be held in the Solar Village. Teaching adults about the cost benefits of solar, the ease of living with solar, current projects, explaining any flukes that may occur and the quick easy install methods is essential. Many rural citizens are very receptive of open house tours where they can freely tour the Solar Homes and take a look at the mechanical systems labeled and displayed.

Missouri S & T has become the forefront of trying to bridge the gap between complex solar topics and the rural public. They do this by making it simple, accessible and a frequently available knowledge

location to the immediate area and beyond. The university gives a lot of encouragement to hands on displays. In the basement of the 2009 home, posters, labels, 3d models, actual solar panels, evacuated tubes, and a solar oven are available for the public to touch and analyze close up. The Department OSE3 has been set up to immediately deal with research going on in the Solar Village and Solar Suburb. Then the university also encourages the production of new homes. The Missouri University of Science and Technology Solar House Design Team concentrates on the next building project and strives to have a net zero home while implementing remarkable technology. The students truly design and are heavily involved in construction of the home. Thus, they are able to pass on information to the local community that solar installation is an easy thing to put together and install. They have first hand knowledge from the design, build, research and livability of what solar is. More often than not tenants of the solar village are officers of the solar house team. In this regard, the students eat, drink, sleep and breathe solar energy and sustainability. Giving tours enables that knowledge to spread to the local community.

Since 2002, Rolla has become a solar friendly town besides just the campus displays. More people than ever have homes, cabins, and businesses powered by the sun. (Hoenfeldt 2016a) There is even a 3.20MW facility that has been constructed by MC Power on property then owned by Rolla Community Development Program. This fixed tilt ground mount sits on 20 acres on the east side of the Hy Point industrial Park. The citizens of Rolla and MoPEP will directly receive energy produced here. The local Phelps County Bank even has a solar drive-through. (Staff Reports 2015) This system provides electricity for ATM machines, lighting and other electric systems in place. Another site for Solar in the community is at Troop I Highway Patrol headquarters with a PV 2KW array system.

All in all, community involvement, volunteer experiences, charity benefits, home shows, eco-festivals, information booths around town, lectures, question and answer periods, local business meetings, live in displays are the suggested ways to sell a rural area on solar. Citizens in these areas want to hear first hand experience, have a platform to have dialogue and soon or later the rural town and countryside homes sway towards the solar way.

Tables

3.1 Flow table

Here is a basic lay out to illustrate the flow of information and then an end result.

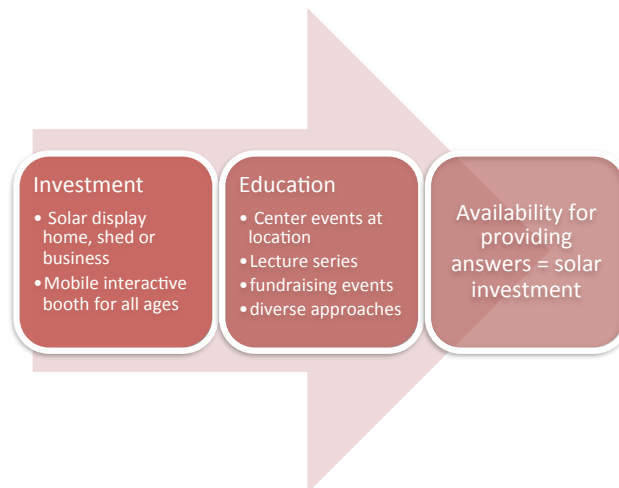

3.2 Figure (Hohenfeldt 2016b)

Artist lay out of 20-acre solar farm with MC Power Companies on property then owned by Rolla Community Development Program. Location is 2301 Brewer Drive, Rolla Missouri.

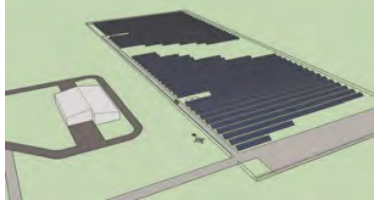

3.3 List for tour breakdown

- Walk around the perimeter of the homes describing outside features
 - Solar array specific to home
 - solar water heater elements
 - research projects in village
 - green house, compost bins, native garden
- Walk through inside of homes
 - appliances
 - passive solar elements
 - architecture
 - US department of Energy Solar Decathlon description
- Basement tour of 2009 home
 - question answer period
 - 3d displays
 - mechanical systems

Appendix: Units and Symbols in Solar Energy

Mega Watts MW
Kilowatts KW
Photo voltaic PV
Kilo watt hour kWh

References

1. Hohenfeldt, RD., Jan. 28 2016. Rolla Solar Farm expected to be Online in Spring. The Rolla Daily News.
2. Sergio Vega Sanchez, 2013. Solar Decathlon Europe 2012 Improving Energy Efficient Buildings. Imprenta Kadmos, Spain.
3. Staff Reports. May 5 2015. Phelps County Bank dedicates solar drive-through. The Rolla Daily News.

Web References

<http://www.solardecathlon.gov/>
<http://solarhouse.mst.edu/>
<https://ose3.mst.edu/>



Collaborative Prototype Development & Test Project for a Novel Hybrid Solar Concentrating Cogeneration System

Mithra Sankrithi¹ and Shani Watkins²

¹ RIC Enterprises, Lake Forest Park, WA (U.S.A.)

² West Sound Technical Skills Center, Bremerton, WA (U.S.A.)

Abstract

"SuperSurya" is a novel, patented hybrid solar concentrating cogeneration system intended to synergistically and cost-effectively harvest both (a) electricity and (b) usable heat for hot water heating and supplementary building heat & optionally swimming pool heating. The electric power is harvested with a low-concentration CPV (concentrated photovoltaic) subsystem using a linear receiver and framed inflatable concentrating mirrors, building upon earlier demonstration of inflatable heliostat technology by RIC Enterprises with some Department Of Energy support. In the SuperSurya configuration, two-axis heliostatic tracking is used to optimize solar energy harvest, and a liquid cooling system uses a heat transfer fluid to convert waste heat from the CPV cooling system into value-added usable heat. Where conventional solar panels only convert around 15 - 20% of incident sunlight into beneficial use for electricity and waste the remaining 80 - 85%; with this cogeneration invention SuperSurya will be targeted to potentially convert 60% of incident sunlight into beneficial use (15 - 20% for electricity, 40 - 45% for usable heat). RIC Enterprises, a Washington State nonprofit corporation, and West Sound Technical Skills Center, a distinctive Washington State technical education institution, are working together collaboratively to design, build and test a full-scale prototype of SuperSurya, the first of its kind in the world. Future offshore versions can efficiently harvest electricity with combined CPV and solar thermal subsystems & synergistically perform low-temperature desalination.

Keywords: *solar, hybrid, concentrating, cogeneration, heating, CPV, heliostatic, tracking, electricity, heat, offshore, efficiently, solar thermal, synergistically, desalination*

1. Introduction

Current photovoltaic solar modules harvest 15- 20% of incoming solar energy, using solar cells such as high-efficiency monocrystalline silicon solar cells. The balance 80 - 85% of incoming solar energy is wasted as waste heat dumped into the environment. Despite this poor harvest efficiency, current solar modules are reasonably cost-effective and have continuing widespread and growing deployment. The solar energy industry could grow even more rapidly if means were available to double or triple solar energy harvest as a percentage of incoming solar energy. This paper presents an introduction to an innovative new technology that leverages a hybrid solar concentrating cogeneration system to harvest both electricity using a low-concentration photovoltaic subsystem, and usable heat using a heat-transfer fluid that captures heat from the concentrating photovoltaic (CPV) subsystem and provides that heat at a useful temperature of 65 - 75 degrees C to a solar hot water heater, as well as for supplementary home or building heating and optionally for swimming pool heating as well.

2. Technology Definition Background

The foundational technology for the hybrid solar concentrating cogeneration system is contained in United States patent US 7,997,264 and United States patent-pending US 2011/0277815, that together disclose the key enabling features and technologies for a hybrid solar concentrating cogeneration system. These key enabling features and technologies include the use of heliostatic tracking; use of framed upwardly concave reflective membranes with an inflation-supported transparent upper surface to keep the reflector surfaces clean and uncontaminated; use of a low-concentration high-efficiency CPV receiver that can use monocrystalline silicon or other solar cells; and use of a CPV cooling system wherein the cooling fluid that keeps the solar cells from overheating also serves as the heat-transfer fluid providing beneficial heat to downstream subsystems such as a solar water heater, supplemental building heat, optional swimming pool heating and an optional added solar thermal electric power generation subsystem. Figures 1 and 2 below provide introductory cover-sheet information on this cited intellectual property.

<p>(12) United States Patent Sankrithi</p> <p>(54) INFLATABLE HELIOSTATIC SOLAR POWER COLLECTOR</p> <p>(75) Inventor: Mithra M. K. V. Sankrithi, Lake Forest Park, WA (US)</p> <p>(73) Assignee: RIC Enterprises, Mountlake Terrace, WA (US)</p> <p>(*) Notice: Subject to any disclaimer, the term of this patent is extended or adjusted under 35 U.S.C. 154(b) by 1232 days.</p> <p>(21) Appl. No.: 11/651,396</p> <p>(22) Filed: Jan. 10, 2007</p> <p>(65) Prior Publication Data US 2010/0229850 A1 Sep. 16, 2010</p> <p>(51) Int. Cl. F24J 2/12 (2006.01)</p> <p>(52) U.S. Cl. 126/697; 126/571; 126/600; 126/692</p> <p>(58) Field of Classification Search 126/571, 126/600, 692, 697 See application file for complete search history.</p> <p>(56) References Cited</p> <p>U.S. PATENT DOCUMENTS</p> <table border="0"> <tr><td>3,031,928 A *</td><td>5/1962</td><td>Kopito</td><td>399/847</td></tr> <tr><td>3,125,091 A *</td><td>3/1964</td><td>Sleeper, Jr.</td><td>126/624</td></tr> <tr><td>3,565,368 A *</td><td>2/1971</td><td>Byron et al.</td><td>244/31</td></tr> <tr><td>3,908,631 A *</td><td>9/1975</td><td>Rom</td><td>126/625</td></tr> <tr><td>3,972,600 A *</td><td>8/1976</td><td>Coburg</td><td>359/840</td></tr> <tr><td>3,976,508 A *</td><td>8/1976</td><td>Mavsky</td><td>136/746</td></tr> <tr><td>4,031,674 A *</td><td>6/1977</td><td>Rand</td><td>522/14</td></tr> <tr><td>4,051,834 A *</td><td>10/1977</td><td>Fletcher et al.</td><td>126/625</td></tr> <tr><td>4,088,120 A *</td><td>5/1978</td><td>Anderson</td><td>126/573</td></tr> <tr><td>4,136,673 A *</td><td>1/1979</td><td>Fischer</td><td>126/606</td></tr> <tr><td>4,160,443 A *</td><td>7/1979</td><td>Brindle et al.</td><td>126/625</td></tr> <tr><td>4,168,696 A *</td><td>9/1979</td><td>Kelly</td><td>126/683</td></tr> </table>	3,031,928 A *	5/1962	Kopito	399/847	3,125,091 A *	3/1964	Sleeper, Jr.	126/624	3,565,368 A *	2/1971	Byron et al.	244/31	3,908,631 A *	9/1975	Rom	126/625	3,972,600 A *	8/1976	Coburg	359/840	3,976,508 A *	8/1976	Mavsky	136/746	4,031,674 A *	6/1977	Rand	522/14	4,051,834 A *	10/1977	Fletcher et al.	126/625	4,088,120 A *	5/1978	Anderson	126/573	4,136,673 A *	1/1979	Fischer	126/606	4,160,443 A *	7/1979	Brindle et al.	126/625	4,168,696 A *	9/1979	Kelly	126/683	<p>(10) Patent No.: US 7,997,264 B2</p> <p>(45) Date of Patent: Aug. 16, 2011</p> <table border="0"> <tr><td>4,171,003 A *</td><td>10/1979</td><td>Forrat</td><td>136/747</td></tr> <tr><td>4,173,213 A *</td><td>11/1979</td><td>Kelly</td><td>126/604</td></tr> <tr><td>4,182,307 A *</td><td>11/1980</td><td>Brindle et al.</td><td>126/625</td></tr> <tr><td>4,203,420 A *</td><td>5/1980</td><td>Schoenfelder</td><td>126/625</td></tr> <tr><td>4,306,540 A *</td><td>12/1981</td><td>Hutchison</td><td>126/607</td></tr> <tr><td>4,317,444 A *</td><td>3/1982</td><td>Maruko</td><td>126/571</td></tr> <tr><td>4,365,616 A *</td><td>12/1982</td><td>Vandenberg</td><td>126/581</td></tr> <tr><td>4,427,838 A *</td><td>1/1984</td><td>Goldman</td><td>136/748</td></tr> <tr><td>4,485,804 A *</td><td>12/1984</td><td>Sharpe</td><td>126/625</td></tr> <tr><td>4,517,957 A *</td><td>5/1985</td><td>Pelley</td><td>126/625</td></tr> <tr><td>4,534,525 A *</td><td>8/1985</td><td>Blaumgart</td><td>244/30</td></tr> <tr><td>5,165,920 A *</td><td>11/1994</td><td>Lechner</td><td>126/696</td></tr> <tr><td>5,404,868 A *</td><td>4/1995</td><td>Sankrithi</td><td>126/604</td></tr> <tr><td>5,893,360 A *</td><td>4/1999</td><td>Stoumen et al.</td><td>126/714</td></tr> <tr><td>6,111,190 A *</td><td>8/2000</td><td>O'Neill</td><td>136/746</td></tr> <tr><td>6,498,290 B1 *</td><td>12/2002</td><td>Lawheed</td><td>136/746</td></tr> <tr><td>6,696,637 B2 *</td><td>2/2004</td><td>Lawheed</td><td>136/746</td></tr> <tr><td>6,897,832 B2 *</td><td>5/2005</td><td>Essig et al.</td><td>343/912</td></tr> </table> <p>(Continued)</p> <p>FOREIGN PATENT DOCUMENTS</p> <p>WO WO 2005003645 A1 * 1/2005</p> <p><i>Primary Examiner</i> — Kenneth B Rinehart <i>Assistant Examiner</i> — Jorge Pereira</p> <p>(57) ABSTRACT</p> <p>Increased utilization of solar power is highly desirable as solar power is a readily available renewable resource with power potential far exceeding total global needs; and as solar power does not contribute to pollutants associated with fossil fuel power, such as unburned hydrocarbons, NOx and carbon dioxide. The present invention provides low-cost inflatable heliostatic solar power collectors, which can be stand-alone units suitable for flexible utilization in small, medium, or utility scale applications. The inflatable heliostatic power collectors use a reflective surface or membrane "sandwiched" between two inflated chambers, and attached solar power receivers which may be of photovoltaic and/or solar thermal types. Modest concentration ratios enable benefits in both reduced cost and increased conversion efficiency, relative to simple prior-art flat plate solar collectors.</p> <p>36 Claims, 31 Drawing Sheets</p>	4,171,003 A *	10/1979	Forrat	136/747	4,173,213 A *	11/1979	Kelly	126/604	4,182,307 A *	11/1980	Brindle et al.	126/625	4,203,420 A *	5/1980	Schoenfelder	126/625	4,306,540 A *	12/1981	Hutchison	126/607	4,317,444 A *	3/1982	Maruko	126/571	4,365,616 A *	12/1982	Vandenberg	126/581	4,427,838 A *	1/1984	Goldman	136/748	4,485,804 A *	12/1984	Sharpe	126/625	4,517,957 A *	5/1985	Pelley	126/625	4,534,525 A *	8/1985	Blaumgart	244/30	5,165,920 A *	11/1994	Lechner	126/696	5,404,868 A *	4/1995	Sankrithi	126/604	5,893,360 A *	4/1999	Stoumen et al.	126/714	6,111,190 A *	8/2000	O'Neill	136/746	6,498,290 B1 *	12/2002	Lawheed	136/746	6,696,637 B2 *	2/2004	Lawheed	136/746	6,897,832 B2 *	5/2005	Essig et al.	343/912
3,031,928 A *	5/1962	Kopito	399/847																																																																																																																						
3,125,091 A *	3/1964	Sleeper, Jr.	126/624																																																																																																																						
3,565,368 A *	2/1971	Byron et al.	244/31																																																																																																																						
3,908,631 A *	9/1975	Rom	126/625																																																																																																																						
3,972,600 A *	8/1976	Coburg	359/840																																																																																																																						
3,976,508 A *	8/1976	Mavsky	136/746																																																																																																																						
4,031,674 A *	6/1977	Rand	522/14																																																																																																																						
4,051,834 A *	10/1977	Fletcher et al.	126/625																																																																																																																						
4,088,120 A *	5/1978	Anderson	126/573																																																																																																																						
4,136,673 A *	1/1979	Fischer	126/606																																																																																																																						
4,160,443 A *	7/1979	Brindle et al.	126/625																																																																																																																						
4,168,696 A *	9/1979	Kelly	126/683																																																																																																																						
4,171,003 A *	10/1979	Forrat	136/747																																																																																																																						
4,173,213 A *	11/1979	Kelly	126/604																																																																																																																						
4,182,307 A *	11/1980	Brindle et al.	126/625																																																																																																																						
4,203,420 A *	5/1980	Schoenfelder	126/625																																																																																																																						
4,306,540 A *	12/1981	Hutchison	126/607																																																																																																																						
4,317,444 A *	3/1982	Maruko	126/571																																																																																																																						
4,365,616 A *	12/1982	Vandenberg	126/581																																																																																																																						
4,427,838 A *	1/1984	Goldman	136/748																																																																																																																						
4,485,804 A *	12/1984	Sharpe	126/625																																																																																																																						
4,517,957 A *	5/1985	Pelley	126/625																																																																																																																						
4,534,525 A *	8/1985	Blaumgart	244/30																																																																																																																						
5,165,920 A *	11/1994	Lechner	126/696																																																																																																																						
5,404,868 A *	4/1995	Sankrithi	126/604																																																																																																																						
5,893,360 A *	4/1999	Stoumen et al.	126/714																																																																																																																						
6,111,190 A *	8/2000	O'Neill	136/746																																																																																																																						
6,498,290 B1 *	12/2002	Lawheed	136/746																																																																																																																						
6,696,637 B2 *	2/2004	Lawheed	136/746																																																																																																																						
6,897,832 B2 *	5/2005	Essig et al.	343/912																																																																																																																						

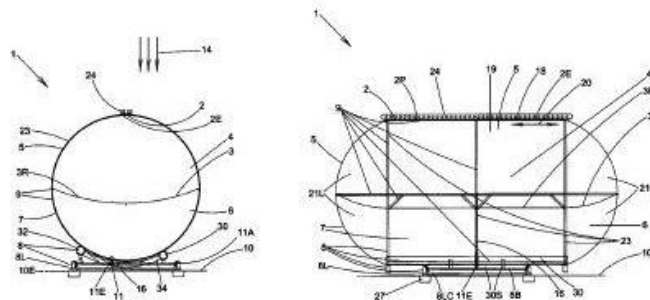

Fig. 1: Technology Definition for an Inflatable Heliostatic Solar Power Collector

(19) United States	
(12) Patent Application Publication	(10) Pub. No.: US 2011/0277815 A1
Sankrithi	(43) Pub. Date: Nov. 17, 2011

(54) INFLATABLE LINEAR HELIOSTATIC CONCENTRATING SOLAR MODULE	(57) ABSTRACT
(76) Inventor: Mithra M.K.V. Sankrithi, Lake Forest park, WA (US)	Increased utilization of solar power is highly desirable as solar power is a readily available renewable resource with power potential far exceeding total global needs; and as solar power does not contribute to pollutants associated with fossil fuel power, such as unburned hydrocarbons, NOx and carbon dioxide. The present invention provides low-cost inflatable heliostatic solar power collectors, which a range of embodiments suitable for flexible utilization in small, medium, or utility scale applications. The inflatable heliostatic power collectors use a reflective surface or membrane "sandwiched" between two inflated chambers, and attached solar power receivers which are of concentrating photovoltaic and optionally also concentrating solar thermal types. Floating embodiments are described for certain beneficial applications on. Modest concentration ratios enable benefits in both reduced cost and increased conversion efficiency, relative to simple prior-art flat plate solar collectors.
(21) Appl. No.: 12/781,610	
(22) Filed: May 17, 2010	
Publication Classification	
(51) Int. Cl.	
H01L 31/052 (2006.01)	
H01L 31/00 (2006.01)	
(52) U.S. Cl.	136/246; 136/259

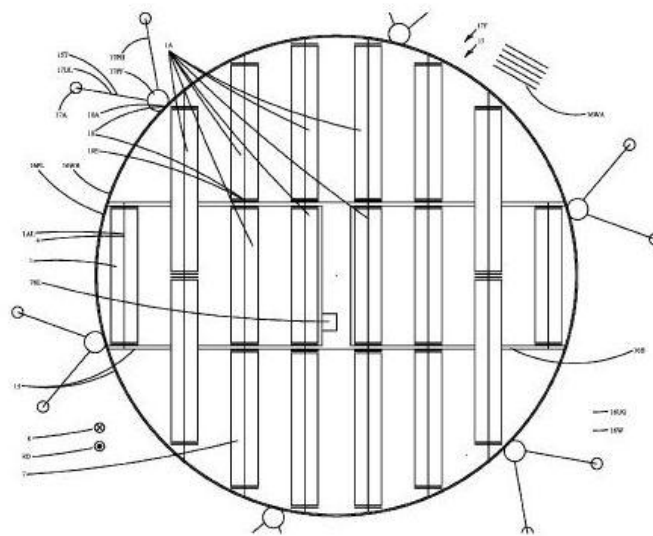

Fig. 2: Technology Definition for a Solar Concentrating Cogeneration System Including a Solar Thermal Subsystem and a Floating Offshore Embodiment

3. Completed Prototype Subsystem Testing

Subsystem technologies for the proposed hybrid solar concentrating cogeneration system have already been prototyped and tested to demonstrate proof-of-concept. As shown in Fig. 3 below, the subsystems that have been tested include:

- Use of a reflective concentrating framed membrane reflector
- Use of a low-cost inflatable structure with a transparent protective weather cover
- Use of an Ethylene Tetrafluoroethylene (ETFE) transparent weather cover that self-cleans in rain
- Use of one and two-axis heliostatic tracking subsystems
- Use of a CPV cooling system using forced air over heat sink extrusions
- Demonstration of an inverted-stow protection concept for storm and hail conditions

SuperSurya Hybrid Solar Concentrating Cogeneration Module & System

Key Design Drivers:

- Harvest 15% of Solar Energy for Electricity + 45% for Usable Heat
- Sturdy, Simple, Reliable, Easy to Maintain and Cost-Effective
- Tolerant of Rain, Snow, Hail, Wind & Storm Conditions
- Residential, Commercial, Public Service Building or Utility Uses
- Good Aesthetics

Target Design Features & Metrics:

- 10 sq.m. Sun Receiver Area; 7.15 Suns Concentration
- 2-Axis Heliostatic Tracking with Sun Sensor & Gearmotors
- Rated power 1.5 kWe plus 4.5 kWt @ 65-75 °C
- Usable Heat for Hot Water, Supplemental Building Heat & Optional Swimming Pool Heating

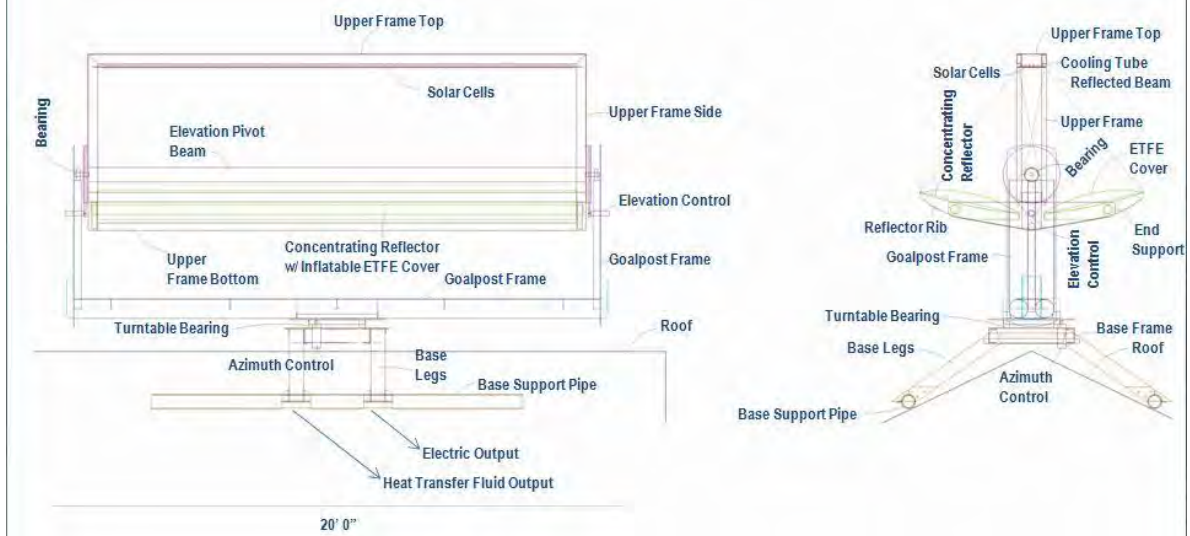

Fig. 4: Baseline SuperSurya Module Design

Following some subsystem testing of the liquid cooling and heat-transfer subsystem, West Sound Tech will build a full-scale fully functional prototype of SuperSurya, and conduct comprehensive testing in collaboration with RIC Enterprises. Contingent on funding and collaboration constraints, the plan is to harvest learnings from the prototype testing to refine the design and proceed to hand-built pre-production units of SuperSurya for sale and monitored in-service testing, and thence on to certification and eventual commercial production. With future collaboration and funding, prototype development and testing is also planned for an Offshore Concentrating Solar (OCS) System that uses a floating offshore assemblage of SuperSurya modules, to harvest electricity with even greater efficiency by adding a solar thermal power subsystem in addition to the CPV subsystem. The OCS System will also be tested with an optional low-temperature desalination system that operates with heat at the 50-60 degrees C range. Fig. 5 below summarizes the project plan and preliminary development plan.

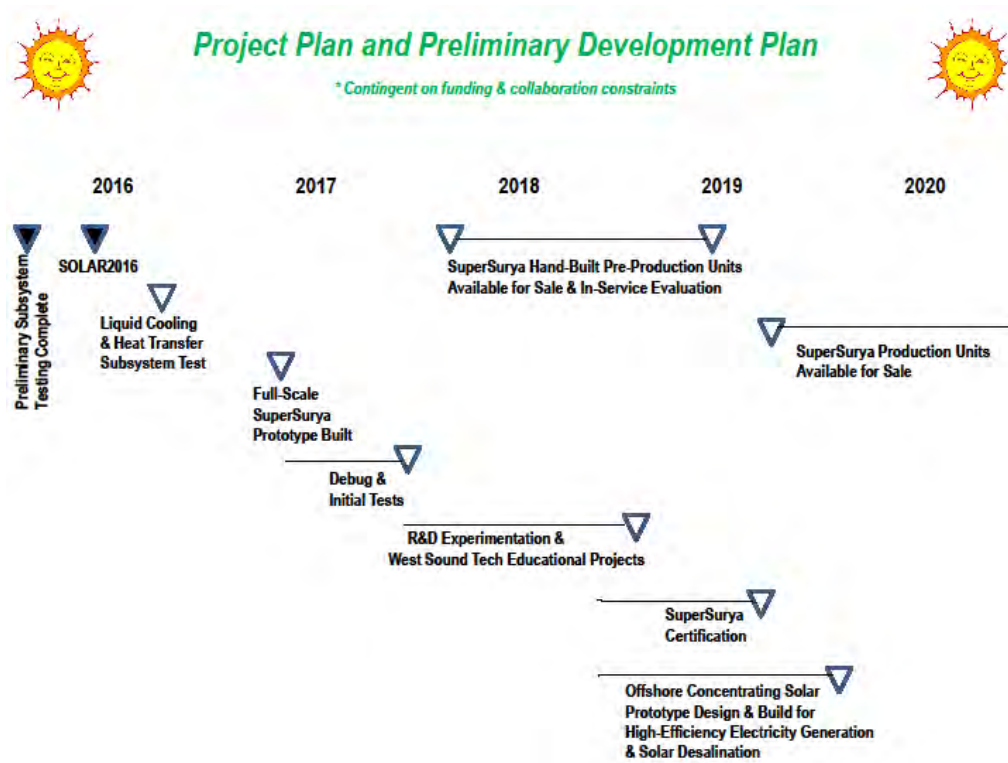

Fig. 5: Baseline Project Plan and Preliminary Development Plan

In the long-term, the dramatic improvement of solar energy harvest increasing from 15-20% of incoming solar energy to around 60% of incoming solar energy, should enable practical, cost-effective and low-risk achievement of a Vision in which these hybrid solar concentrating cogeneration technologies find wide application for residential customers, public sector customers such as schools, libraries and community centers, and commercial and industrial customers as well. The Concentrating Offshore Solar (COS) Systems can find farm/ranch-scale and utility-scale applications for extremely efficient electric power generation with essentially zero land use. Finally, future developments of COS Systems can also cost-effectively provide solar-powered desalination systems to provide clean potable water for coastal communities in arid areas of the World.

Fig. 6 below summarizes this Vision of potential wide-ranging applications. RIC Enterprises (ricenterprisesinvent@gmail.com) welcomes discussion with colleagues and collaborators on potential additional Research, Development and Demonstration (RD&D) activities that can accelerate development and deployment of this promising new approach for the benefit of humankind and our global environment.

LONG-TERM VISION : Widespread Applications of 'Green' Cost-Effective Hybrid Solar Concentrating Cogeneration Systems for Electricity, Heating & Water

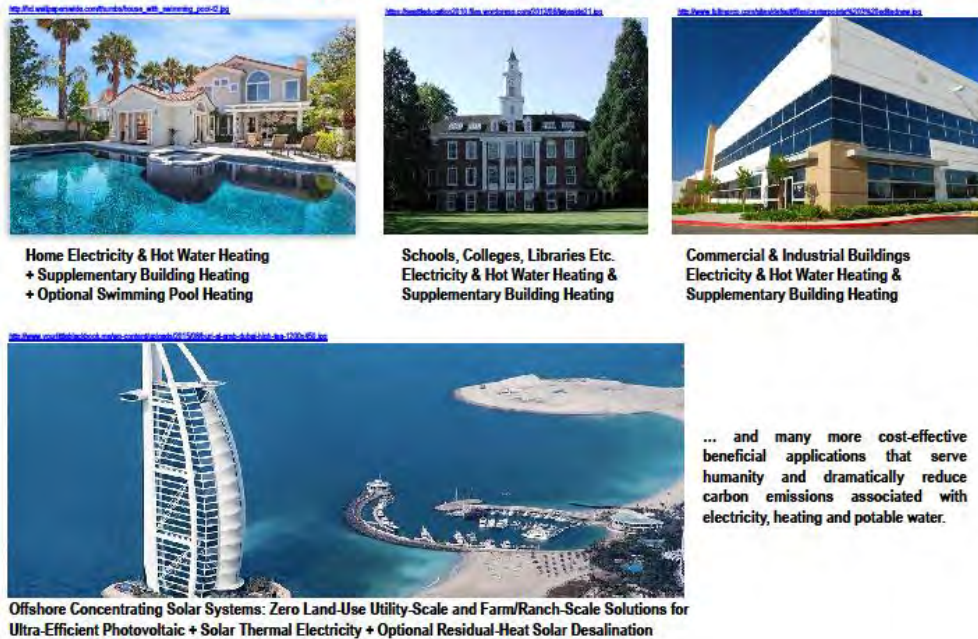

Fig. 6: Long-Term Vision for Hybrid Solar Concentrating Cogeneration System Applications

5. Conclusions

Work is progressing satisfactorily on the design and development of a novel, patented hybrid solar concentrating cogeneration system. A full-scale system being prototyped is designed to harvest 1.5 kilowatts of electric power (1.5 kWe) and 4.5 kilowatts of usable thermal power (4.5 kWt), capturing approximately 60% of incoming solar energy, and leveraging a liquid-cooled CPV subsystem that employs a working heat transfer fluid at 65 - 75 degrees C to provide high-value usable heat for a solar hot water heater as well as remaining usable heat for supplementary home or building heating and optionally swimming pool heating. The target 60% energy harvest is approximately triple the level obtainable from conventional solar panels with high-efficiency monocrystalline silicon solar cells. A roadmap for development includes already completed subsystem tests and upcoming full-scale prototype tests, leading to pre-production units for in-service evaluation. Future developments are also targeted to include a floating embodiment for offshore use, that can very efficiently harvest solar energy with no land use, and cost-effectively yield beneficial combinations of electricity, usable heat, and optionally also desalinated water through use of a low-temperature solar desalination subsystem.

6. References

Sankrithi, M, Sankrithi, U, 2010. Prototype Development and Testing of Inflatable Concentrating Solar Power Systems. SOLAR2010, Paper 0251.

Sankrithi, M, Sankrithi, U, 2012. Beneficial Applications of Inflatable Heliostatic Mirrors. World Renewable Energy Forum, Paper 0273.

Author Index

A

D.W. Aitken

<i>SMUD Solar: A Roadmap for Utilities in Transition</i>	33
--	----

B

R. Beller

<i>Inhouse</i>	55
----------------------	----

G. Bender

<i>Global Validation of REST2 Incorporated Into an Operational DNI and GHI Irradiance</i> ...	84
---	----

<i>Solar Energy Assessments: When Is a Typical Meteorological Year Good Enough?</i>	77
---	----

J. Bourg

<i>The Right Tone of VOS: Improving the Argument for Local Community Solar</i>	178
--	-----

L. Branco

<i>Case Study of a Solar Power Installation on an Automated Transit Network in San Jose</i>	157
---	-----

C

C. Cassidy

<i>Forecasting Solar Power and Irradiance – Lessons from Real-World Experiences</i>	112
---	-----

N.V. Chalfoun

<i>House Energy Doctor's Level III Building Energy Audits as Pedagogy and Outreach</i>	66
--	----

J. Cliburn

<i>The Right Tone of VOS: Improving the Argument for Local Community Solar</i>	178
--	-----

D.L. Comis

<i>Maryland Net Zero Energy Schools Program</i>	61
---	----

S.J. Cox

<i>An Assessment of New Satellite Data Products for the Development of a Long-term Global</i> ...	121
---	-----

D

D. Drake

A Case Study on the Merits and Design of a Solar Powered Internet of Things: Intelligent... 4

E

B. Esser

Influencing Utilities Through Shareholder Advocacy: the Madison Gas & Electric Case... 188

F

A.M. Farrag

Design of Wearable Agricultural Solar-powered Sprayer for Remote Areas..... 202

B.J. Furman

Case Study of a Solar Power Installation on an Automated Transit Network in San Jose..... 157

The Spartan Superway: A Solar-Powered Automated Transportation Network..... 147

G

I. Gendler

A Study on the Effects of Urban Shadow Impingement on Solar Powered Transportation... 167

D.G. Giacobbo

Challenges for the Expansion of Solar Power in Brazil..... 212

J. Glenn

Solar Power for Rural America..... 219

W.T. Gustafson

Global Validation of REST2 Incorporated Into an Operational DNI and GHI Irradiance... 84

H

M. Hatch

Guidelines for Residential Sub Metering 44

C. Hazel

Design Schools as Drivers for Sustainable & Affordable Housing 12

I

L.D. Iulo

Design Schools as Drivers for Sustainable & Affordable Housing 12

J

P.M. Jansson

Net Metering PV Distributed Resources Benefits All Stakeholders on PJM 194

S.D. Jascourt

Forecasting Solar Power and Irradiance – Lessons from Real-World Experiences 112

K

R. Kenny

Solar Energy Assessments: When Is a Typical Meteorological Year Good Enough? 77

D. Kirk-Davidhoff

Forecasting Solar Power and Irradiance – Lessons from Real-World Experiences 112

K. Knapp

An Assessment of New Satellite Data Products for the Development of a Long-term Global... 121

L

L. Leahy

<i>Global Validation of REST2 Incorporated Into an Operational DNI and GHI Irradiance...</i>	84
<i>Solar Energy Assessments: When Is a Typical Meteorological Year Good Enough?</i>	77

M

C. Maalouf

<i>Solar Energy Assessments: When Is a Typical Meteorological Year Good Enough?</i>	77
---	----

D. Marques de Queiroz Neto

<i>Case Study of a Solar Power Installation on an Automated Transit Network in San Jose</i>	157
---	-----

J.C. Mikovitz

<i>An Assessment of New Satellite Data Products for the Development of a Long-term Global...</i>	121
--	-----

L. Mueller

<i>Inhouse</i>	55
----------------	----

W. Murray

<i>Some Consequences to Grid Operation Due to High Penetration of Distributed PV Systems</i>	94
--	----

O

G. Olson

<i>Solar Thermal Collection with Seasonal Storage</i>	137
---	-----

D.E. Osborn

<i>SMUD Solar: A Roadmap for Utilities in Transition</i>	33
--	----

P

A. Parr

<i>Inhouse</i>	55
----------------	----

S. Pelland

<i>Solar Energy Assessments: When Is a Typical Meteorological Year Good Enough?</i>	77
---	----

R. Perez

<i>An Assessment of New Satellite Data Products for the Development of a Long-term Global...</i>	121
<i>Introduction</i>	2

U. Ponsukcharoen

<i>Some Consequences to Grid Operation Due to High Penetration of Distributed PV Systems</i>	94
--	----

J. Powers
The Right Tone of VOS: Improving the Argument for Local Community Solar 178

J.S. Preston
A Case Study on the Merits and Design of a Solar Powered Internet of Things: Intelligent... 4

R

J. Ranalli
Assessing Demand Impact of Solar Capacity Growth in Philadelphia 104

H. Rashed-Ali
Guidelines for Residential Sub Metering 44

E. Rosenfeld
Case Study of a Solar Power Installation on an Automated Transit Network in San Jose 157

S

M. Sankrithi
Collaborative Prototype Development & Test Project for a Novel Hybrid Solar Concentrating... 223

B. Scarino
An Assessment of New Satellite Data Products for the Development of a Long-term Global... 121

J. Schaefer
Comparing Carbon Fees with Existing Financial Incentives for Solar Electricity 22

W. Schirtzinger
SMUD Solar: A Roadmap for Utilities in Transition 33

J. Schlemmer
An Assessment of New Satellite Data Products for the Development of a Long-term Global... 121

B. Schneider
Solar Energy Assessments: When Is a Typical Meteorological Year Good Enough? 77

K. Schollenberger
Inhouse 55

E.I. Schwartz
The Hazards of Exponential Growth for the Solar Industry – and How Innovating Stronger... 28

M. Sengupta
An Assessment of New Satellite Data Products for the Development of a Long-term Global... 121

P.W. Stackhouse
An Assessment of New Satellite Data Products for the Development of a Long-term Global... 121

S. Stannard	
<i>Inhouse</i>	55
B. Stickney	
<i>'New Standard' Solar Hydronic Building Systems: State of the Art in New Mexico 2016</i>	128
S.J. Strong	
<i>SMUD Solar: A Roadmap for Utilities in Transition</i>	33

W

S. Watkins	
<i>Collaborative Prototype Development & Test Project for a Novel Hybrid Solar Concentrating</i>	223
D. Wichert	
<i>Influencing Utilities Through Shareholder Advocacy: the Madison Gas & Electric Case</i>	188

Y

Y. Yu	
<i>Solar Thermal Collection with Seasonal Storage</i>	137

Z

T. Zhang	
<i>An Assessment of New Satellite Data Products for the Development of a Long-term Global</i>	121